

Hande®



**A NEW
GENERATION FLOORING**

Woven Vinyl Flooring

Guangzhou Hande New Materials Co.,Ltd

Tel: 020-32222815

Mail: zhenghui.xu@handegroup.com.cn

Add: No. 161, Yao Tian He Street, Yongshun Avenue, Yonghe Economic Zone,
Guangzhou Economic & Technology Development District, Guangzhou China

www.handegroup.com.cn



FORWARD

Hande is a shining new star in the field of vinyl woven flooring. Our original intention is to continuously explore the most ideal solutions among fashion, practicality and high quality. Our carpet not only have powerful functions such as waterproof, stain-resistant and fireproof, but also have excellent antibacterial and anti-slip properties, providing more health care for children and the elderly. In addition, the extremely artistic and design-oriented woven texture, gives the ground space an appearance that is both healthy, fresh, comfortable and exudes unique charm.

Welcome to our world, an innovative and sincere brand.





Hande—20 years woven fabrics production experience

Hande factory has 20 years of production experience in woven fabrics, which was acquired from the world's largest sunshade window covering enterprise Hunter Group. We specialize in manufacturing woven fabrics for sunshading, floor and outdoor furniture.



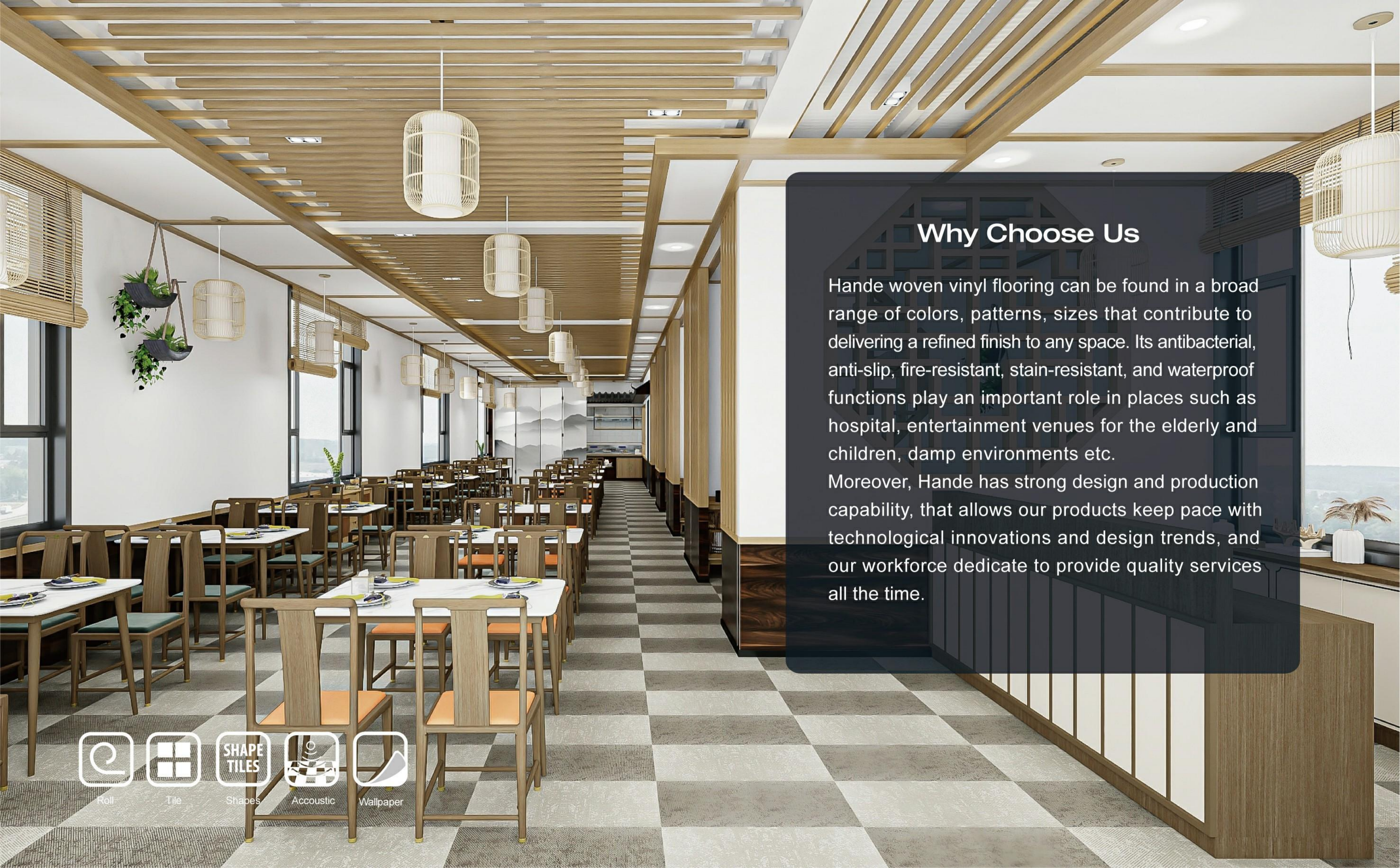

Why Choose Us

Hande woven vinyl flooring can be found in a broad range of colors, patterns, sizes that contribute to delivering a refined finish to any space. Its antibacterial, anti-slip, fire-resistant, stain-resistant, and waterproof functions play an important role in places such as hospital, entertainment venues for the elderly and children, damp environments etc.

Moreover, Hande has strong design and production capability, that allows our products keep pace with technological innovations and design trends, and our workforce dedicate to provide quality services all the time.



Roll



Tile



Shapes



Acoustic



Wallpaper



PRODUCT PROPERTIES

- » **Quiet and Comfortable:** Determined by our quality and make, vinyl flooring is softness and quiet.
- » **Durable appearance:** Our woven texture are durable and the patterns will not easily become flat during use.
- » **Easy to clean:** Our woven texture are durable and the patterns will not easily become flat during use.
- » **Antibacterial Protection:** The surface yarn is antibacterial treated, which can prevent the growth of mold, bacteria, etc., and maintain a healthy and odorless state.
- » **Waterproof and Stain Resistant:** The impervious backing prevents liquid penetrating through the floor covering. It resists stains by not absorbing liquids and thus making spills easy to clean.
- » **Convenient Installation:** The installation and construction are convenient and fast. If the ground condition is good, without cement mortar, a special environmentally friendly adhesive can be selected for bonding, and it can be used after 24 hours.

CHARACTERISTIC	HanDe®	CARPET	HARD WOOD	OTHER TYPICAL FLOORS
Textile Appearance	○	○	-	-
Easy Maintenance	○	-	○	-
Water Resistant	○	-	-	-
Stain Resistant	○	-	-	-
Appearance Retention Over Time	○	○	○	-
Comfort Underfoot	○	○	-	-
Scratch Resistant	○	○	-	-
Antistatic	○	○	○	○
Low Allergy	○	-	○	○
Ease of Rolling Loads	○	-	○	○
Resistance to Microbial Growth	○	-	○	○
Life Expectancy Years(10+)	○	-	○	○

1. PUBLIC SPACES
2. WORKSPACE
3. SHOWROOM & EXHIBITION
4. RETAIL
5. HOSPITALITY
6. HEALTHCARE
7. RECEPTION & WAITING AREAS
8. BUSY HOMES WITH CHILDREN OR PETS
9. OUTDOOR GATHERING SPACES
10. WET ENVIRONMENT
11. ANTIBACTERIAL-NEEDED PLACES
12. SLIP RESISTANCE-NEEDED FOR ELDERLY



Area of Application

Hande woven vinyl flooring as an outstanding one, not only being waterproof, fire resistant, but also anti-slip and stain resistant, which making it ideal for application in residential & commercial places. Meanwhile our woven design flooring can also applied in outdoor locations with shelter where there is a high demand for skid resistance, such as swimming pools and stairs.

Multiple Sizes For Your Choice

Company that allows you to choose with various shapes to create inspiring floors in woven vinyl.

LINK

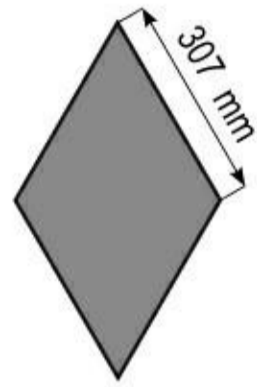

HEXAGON

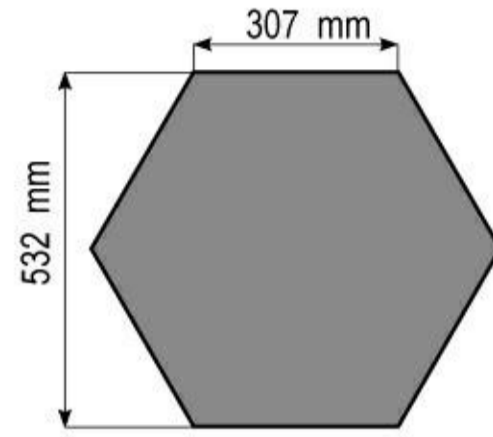

SCALE

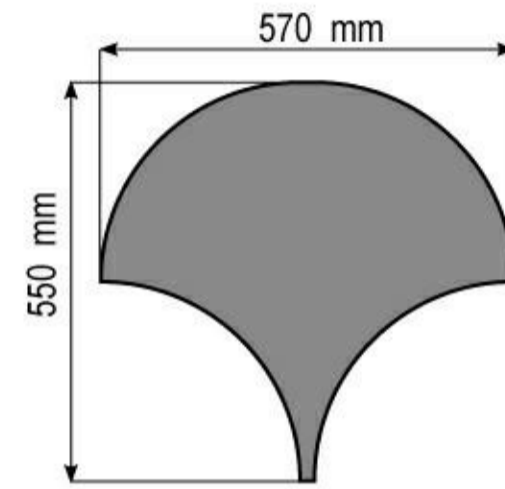

WAVE

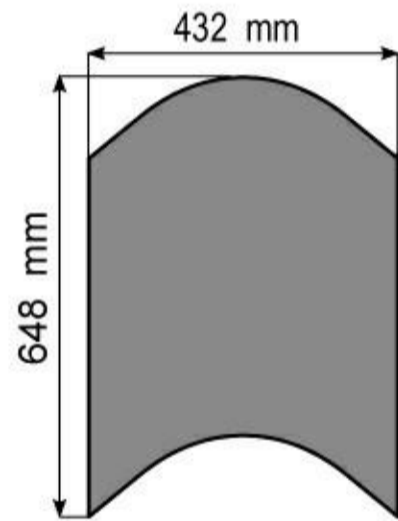

DECO

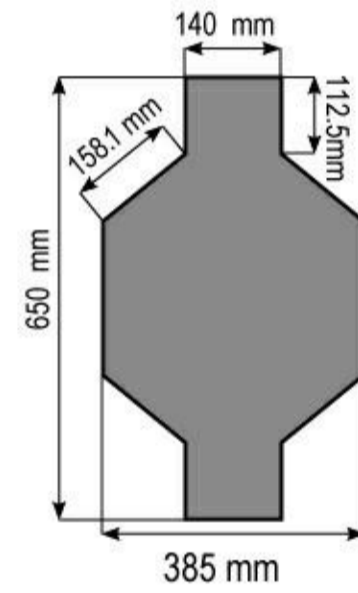

WING

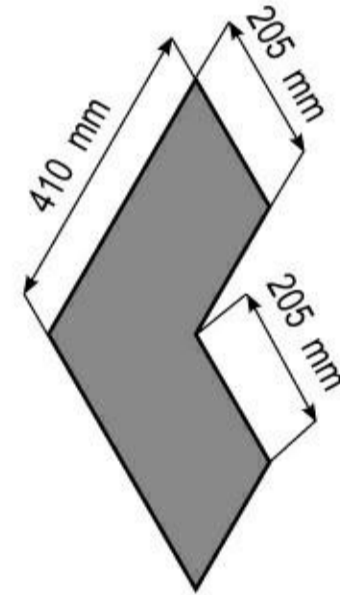

TRIANGLE 500

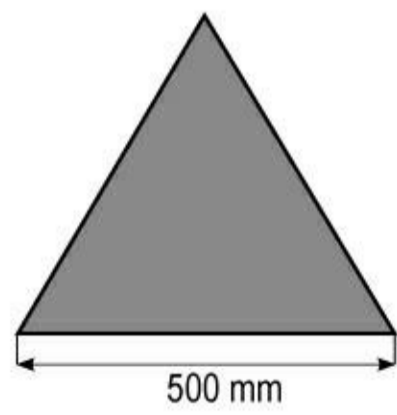

TRIANGLE 650

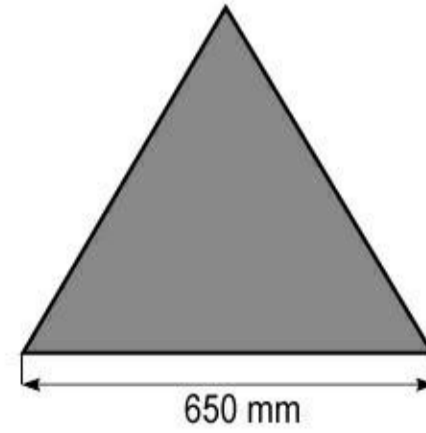

TRIANGLE 754

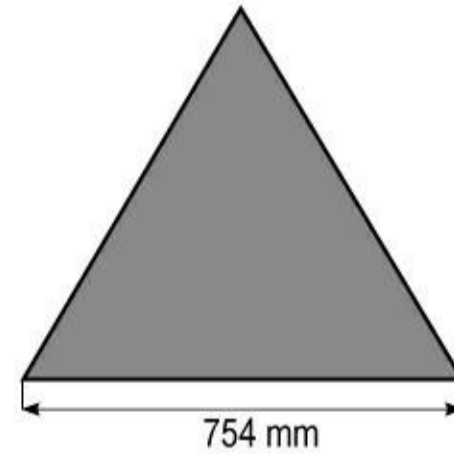

RECTANGLE

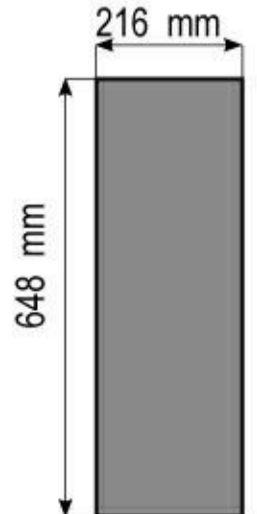

PLANKS

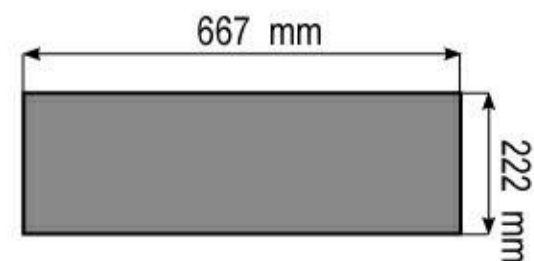

50 X 50 CM TILES

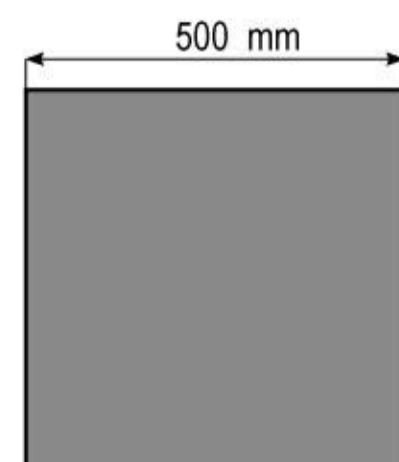



QUIET

Quiet series features a classic dual-color jacquard design with elegant, tranquil hues. It creates a unique artistic ambiance, providing a sense of peace and elegance amid bustling city life.

SQUARE TILES

OFFICE

QUIET



SK08

* COLOURS MAY BE SLIGHTLY DIFFERENT FROM THE ACTURAL ONES



Roll



Tile



Shapes



Accoustic



Wallpaper



JA07



JA57



JA94

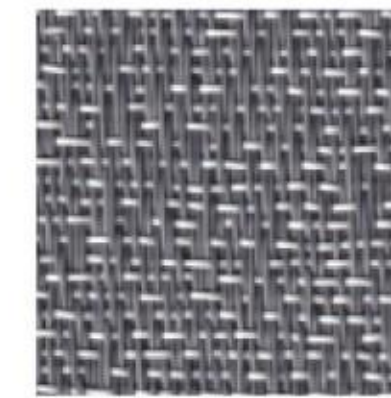

SK01



SK02

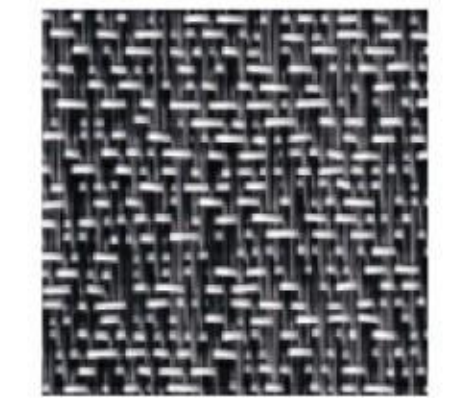

SK04

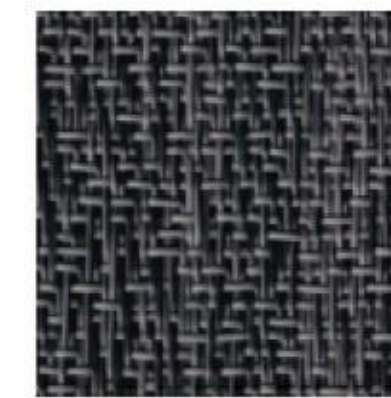

SK06



SK08

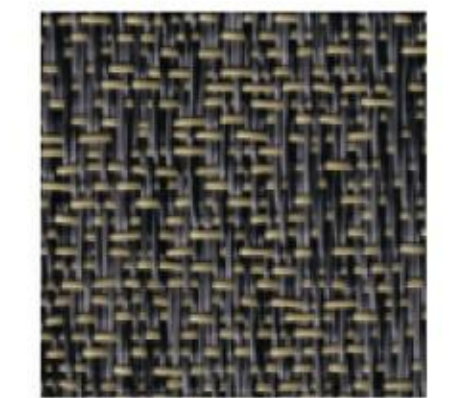

SK09



SK10

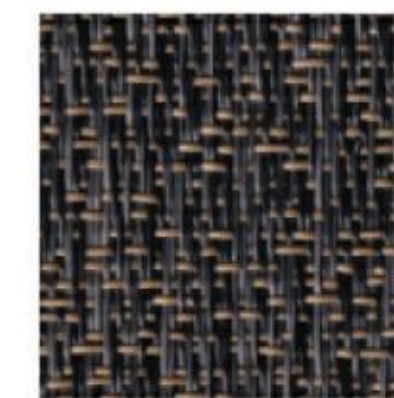

SK11



SQUARE TILES

LIVING ROOM

IMAGINE

NATURE

GARDEN



JM15 JM20 JM19



MZ07



FL05

* COLOURS MAY BE SLIGHTLY DIFFERENT FROM THE ACTURAL ONES



Roll Tile Shapes Accoustic Wallpaper

IMAGINE

Imagine series fabric features a dual-color jacquard twill structure that conveys stability and strength. Its distinctive dual-color texture creates a simple yet engaging pattern. Combining warmth with subtlety, it inspires endless creativity in expressing introverted charm.

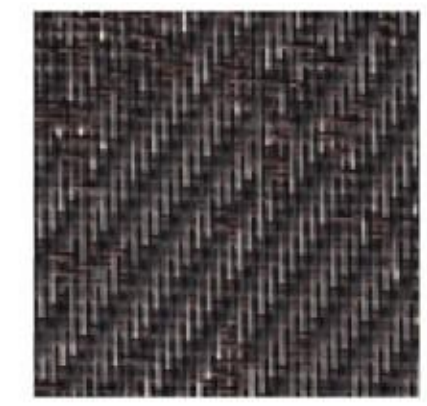

JM84

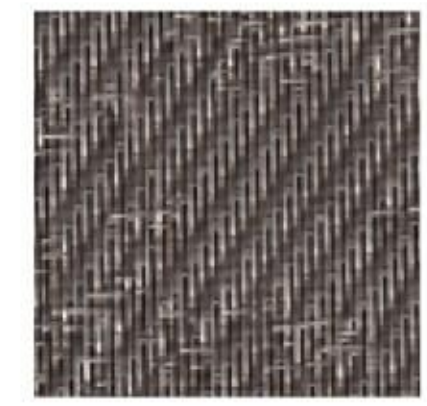

JM12

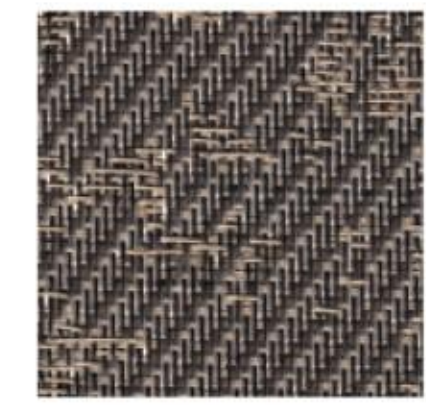

JM13

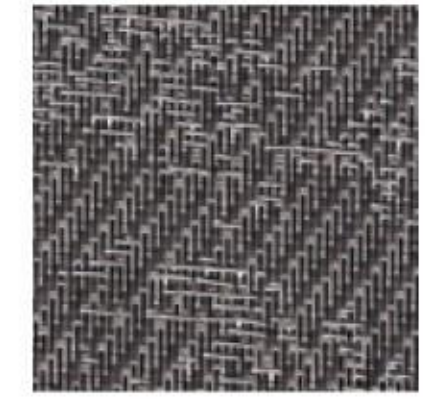

JM15

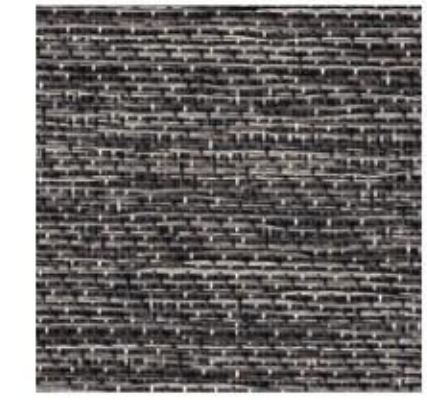

JM17

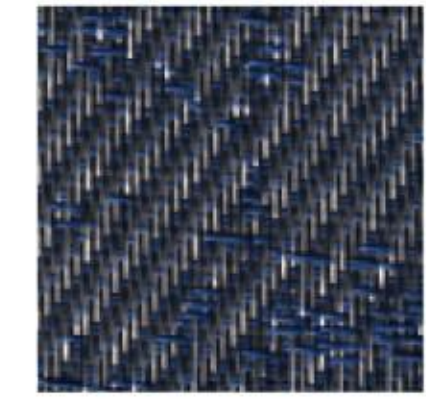

JM19

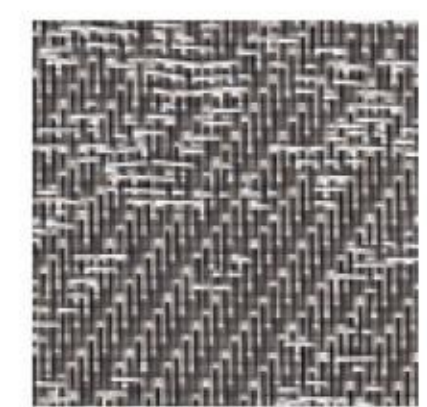

JM20

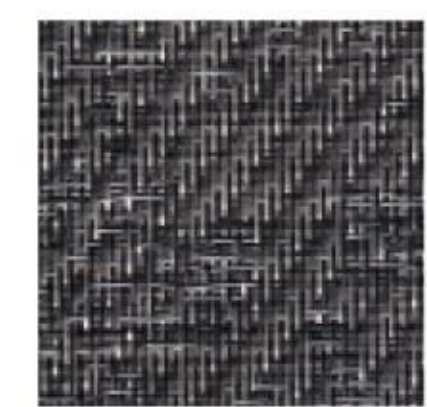

JM21



SQUARE TILES

HOTEL ROOM

GARDEN



JM33 JM34

* COLOURS MAY BE SLIGHTLY DIFFERENT FROM THE ACTURAL ONES



GARDEN

Garden series features a mercury tricolor jacquard structure, showcasing a vibrant palette. It includes a passionate red, a serene light green, and a mysterious dark tone. The color gradient transitions from light to dark and from bright to deep, enabling customers to create their unique artistic style.

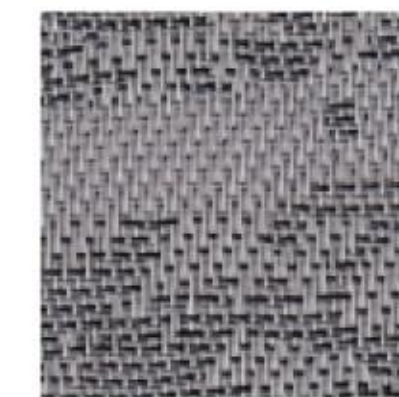

JM83

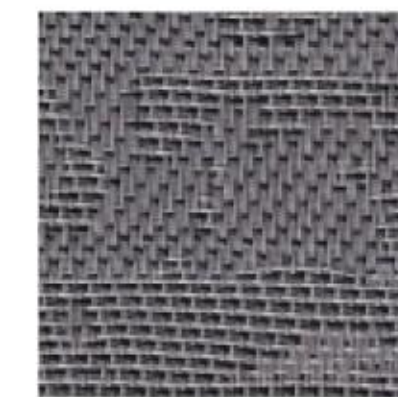

JM85



JM34



JM33



JM35



FL05



FL54



FL45

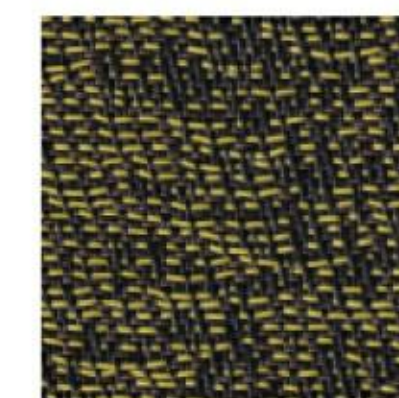

FL46

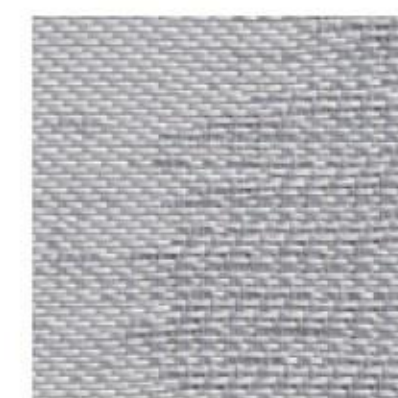

FL53



FL61



FL55

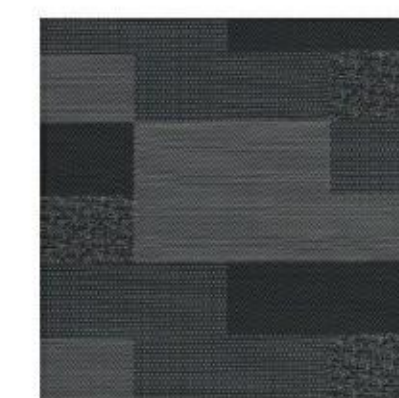

JS01



JS07



SQUARE TILES

BEDROOM

HOTEL



FG30

* COLOURS MAY BE SLIGHTLY DIFFERENT FROM THE ACTURAL ONES



Roll



Tile



SHAPE
TILES

Shapes



Accoustic



Wallpaper

HOTEL

The hotel series fabric features a dual-color jacquard design with patterns reminiscent of Chinese ink landscapes, depicting flowing mountains and rivers. This collection exudes grandeur and a classical artistic vibe, enhancing the hotel's exquisite elegance while showcasing the unique charm of hotel space.



FG29



FG30



FG31



FG32

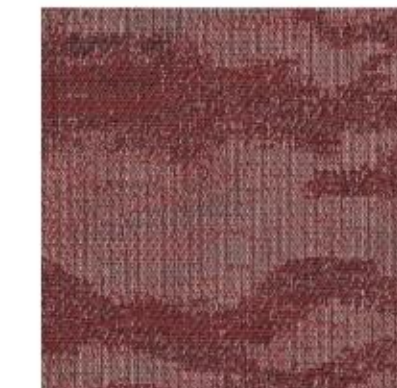

FG33



FG01



FG02



TG05



NATURE

Nature series features a dual-color plain weave design. It is soft, elegant, warm, and showcases natural colors. When used indoors, the fabric creates a bright, fresh, and calm atmosphere, enhancing the space with a unique artistic style that embraces and connects with nature.



DT68



DT97

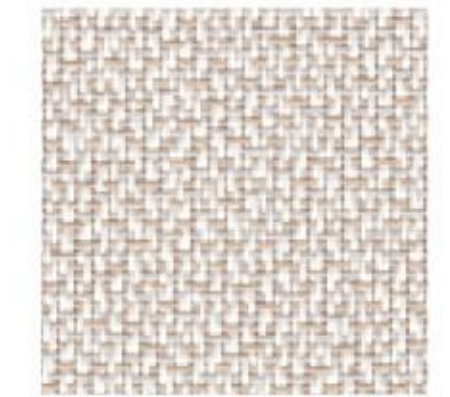

MZ32

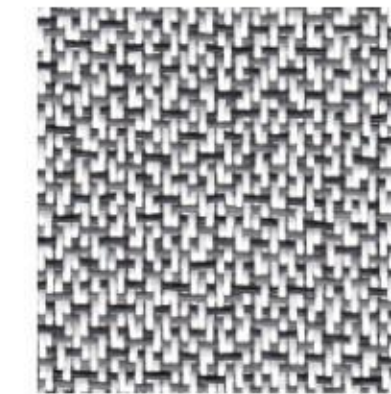

MZ31



MZ07



OB69

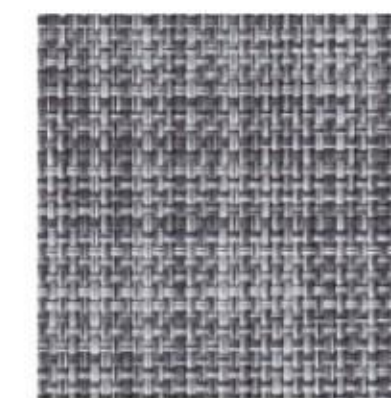

OB68



WM66



WM36



WM37

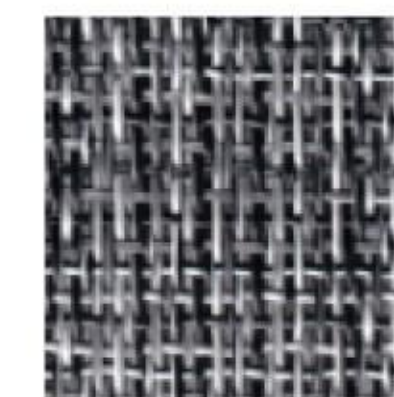

WM92

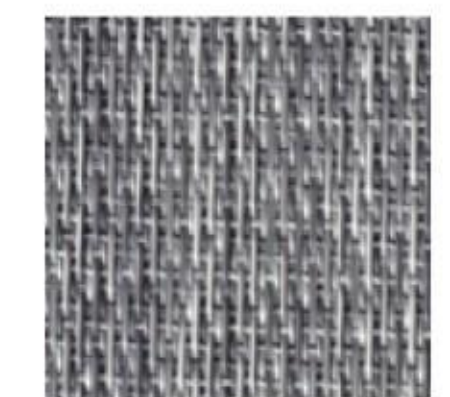

WM93

SQUARE TILES

PRIVATE OFFICE

NATURE

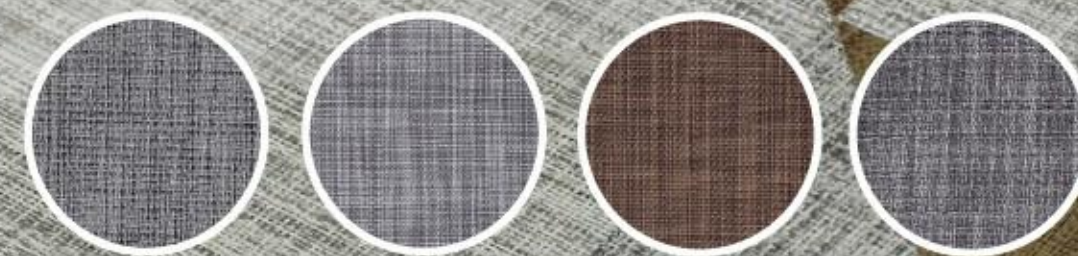

WM-36 OB68 OB69 DT68

* COLOURS MAY BE SLIGHTLY DIFFERENT FROM THE ACTURAL ONES



Roll



Tile



Shapes



Acoustic



Wallpaper



SQUARE TILES

DINING ROOM

GRADIENT

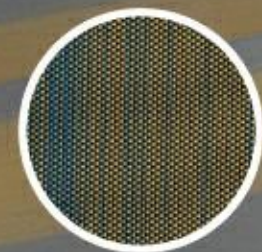

FD02

* COLOURS MAY BE SLIGHTLY DIFFERENT FROM THE ACTURAL ONES



Roll



Tile



Shapes



Accoustic



Wallpaper

GRADIENT

Gradient series fabric features a plain weave design. This creates an artistic effect characterized by the blending and clash of colors, resulting in a majestic, elegant, and subtly noble appearance.



FD01  

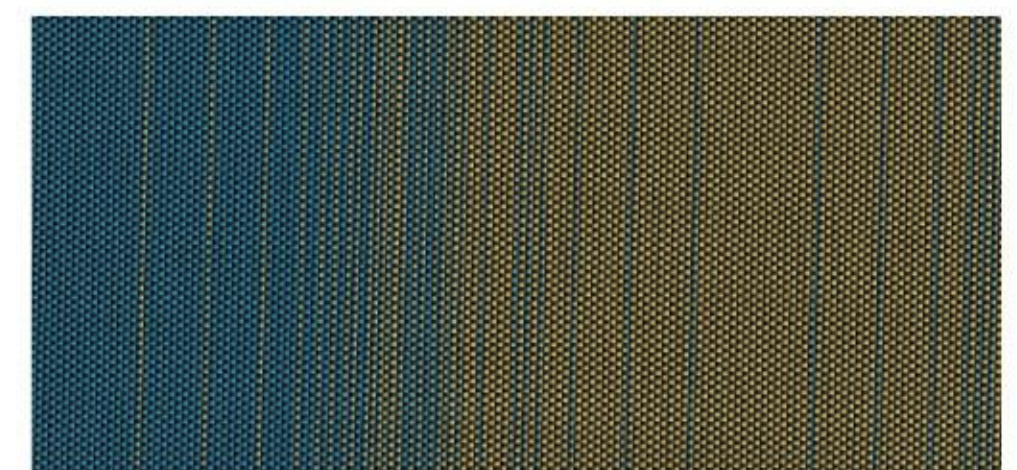

FD02  



FD03  



SQUARE TILES

LIVING ROOM

RIPPLE



FL35

* COLOURS MAY BE SLIGHTLY DIFFERENT FROM THE ACTURAL ONES



Roll



Tile



Shapes



Accoustic



Wallpaper

RIPPLE

Ripple series features twill jacquard structure, a unique weaving structure, it offers a visual effect like the shimmering water surface sharing a warm, peaceful, and natural artistic feeling to people.

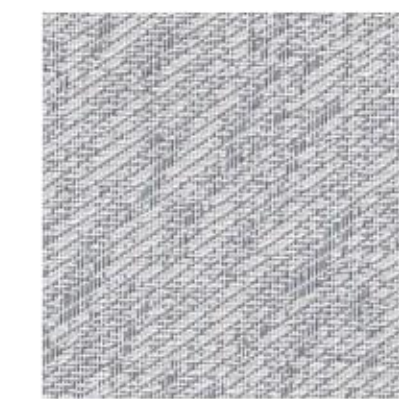

FL23



FL25



FL34



FL35



FL36



FL37



FL38



FL39



FL40



FL41

SQUARE TILES

OFFICE
QUIET SERIES



SK09

* COLOURS MAY BE SLIGHTLY DIFFERENT FROM THE ACTURAL ONES



Roll



Tile



Shapes



Accoustic



Wallpaper

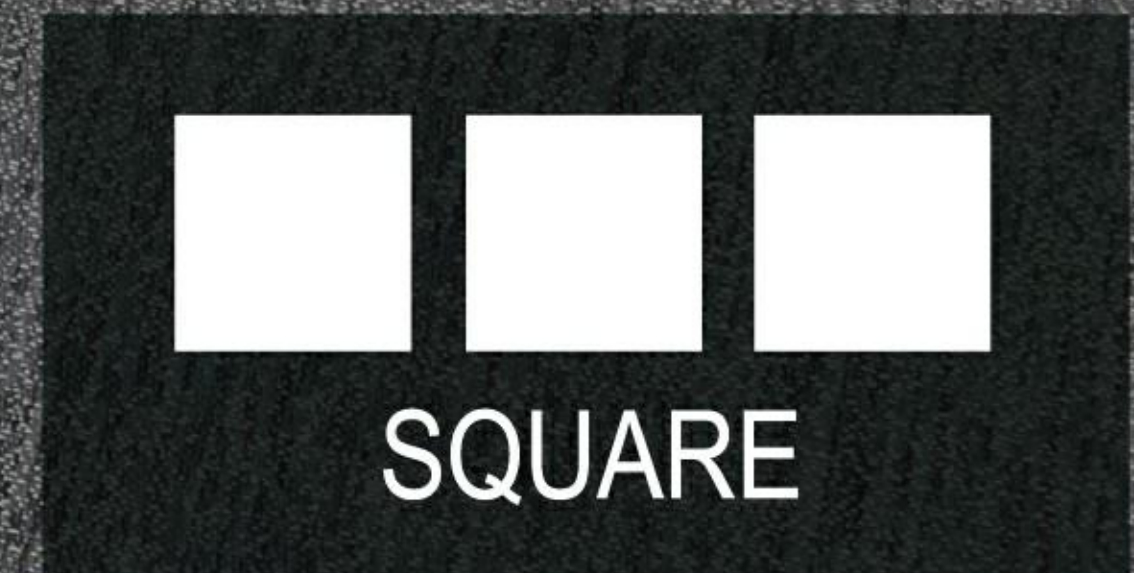

SQUARE TILES

OFFICE
QUIET SERIES



SK08

COLOURS MAY BE SLIGHTLY DIFFERENT FROM THE ACTURAL ONES



Roll



Tile



Shapes



Accoustic



Wallpaper

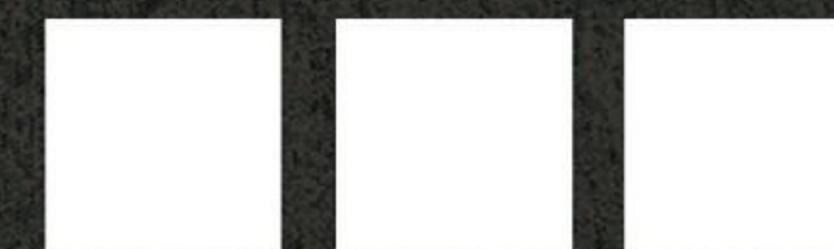

SQUARE



SQUARE TILES

ART SPACE

QUIET SERIES



SK08 SK09

NATURE



OB69 MZ32

* COLOURS MAY BE SLIGHTLY DIFFERENT FROM THE ACTURAL ONES

-  Roll
-  Tile
-  SHAP
TILES
Shapes
-  Acoustic
-  Wallpaper

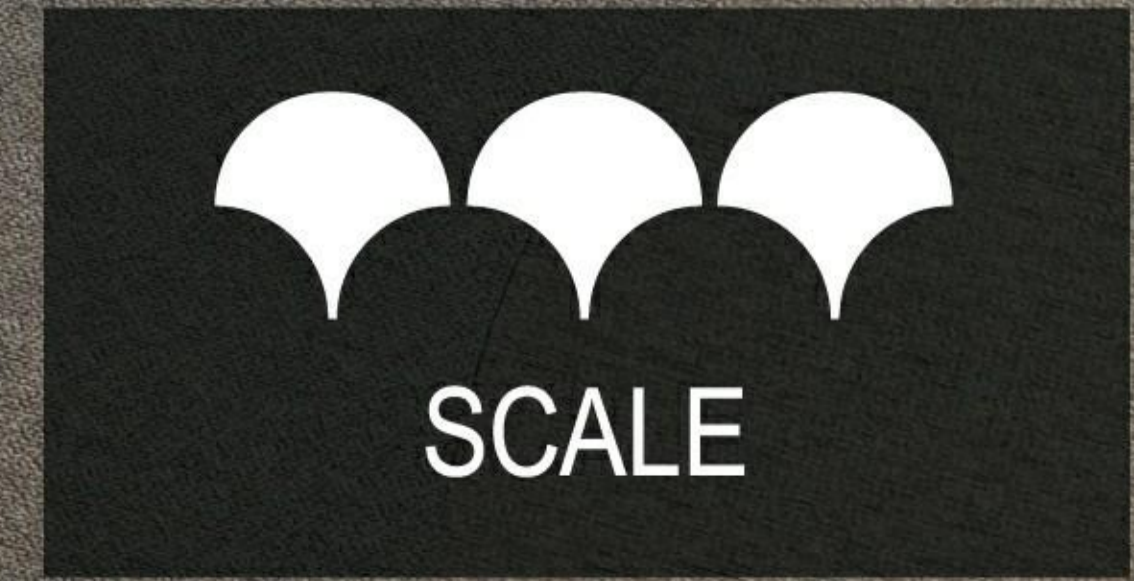

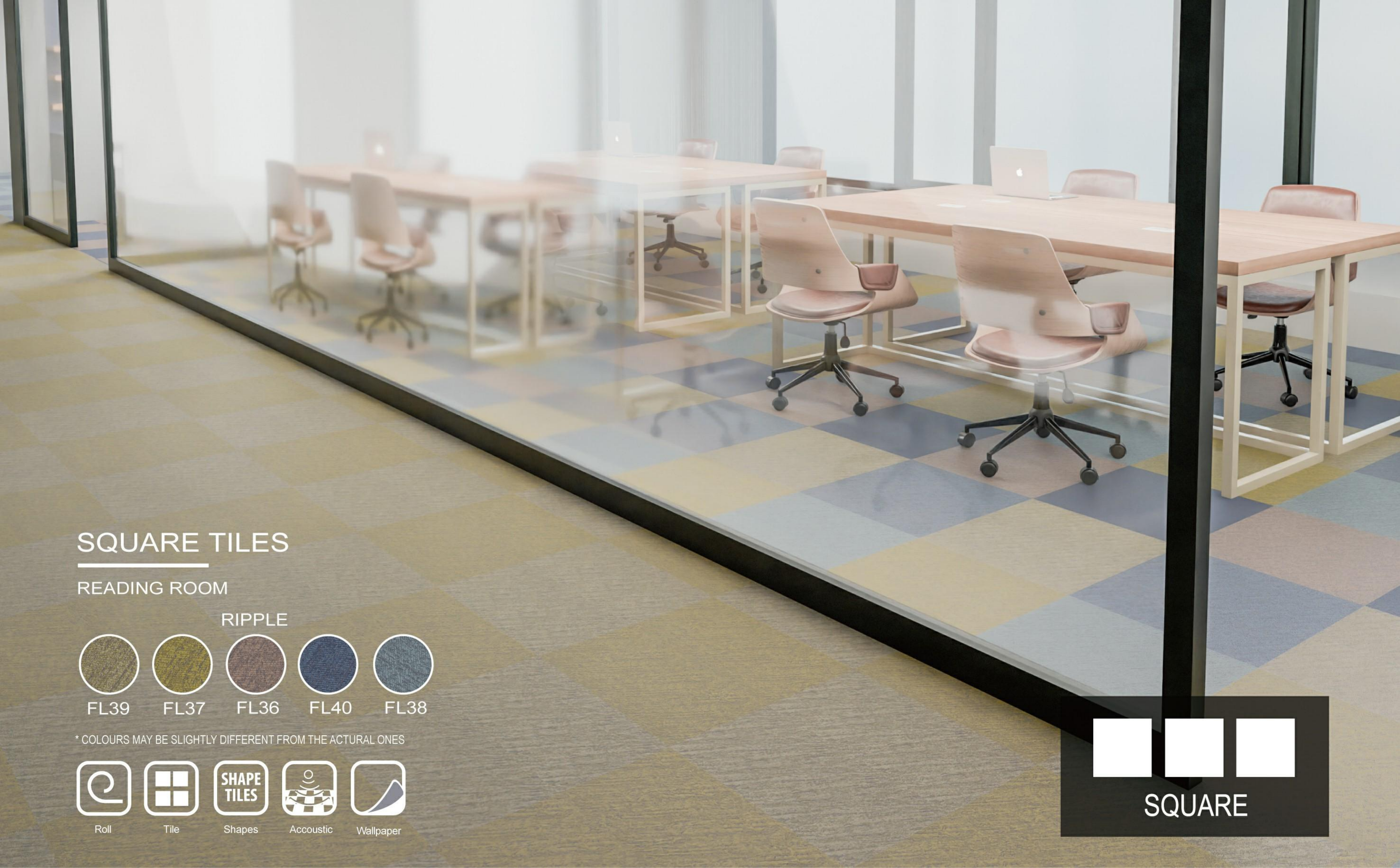

SQUARE TILES

READING ROOM

RIPPLE

-  FL39
-  FL37
-  FL36
-  FL40
-  FL38

* COLOURS MAY BE SLIGHTLY DIFFERENT FROM THE ACTURAL ONES

-  Roll
-  Tile
-  SHAPE TILES
Shapes
-  Acoustic
-  Wallpaper



SQUARE



SQUARE TILES

OFFICE
GARDEN



JM83

* COLOURS MAY BE SLIGHTLY DIFFERENT FROM THE ACTURAL ONES



Roll



Tile



SHAPE
TILES

Shapes



Accoustic



Wallpaper





SQUARE TILES

DINING ROOM

RIPPLE



FL40

* COLOURS MAY BE SLIGHTLY DIFFERENT FROM THE ACTURAL ONES



Roll



Tile



Shapes



Accoustic



Wallpaper



SQUARE

SUPPORT & SERVICE

In order to provide customers with the most comprehensive support and service, we combine departments such as sales, marketing, technology and design into a powerful after-sales team so that we can solve all kinds of product-related problems for customers promptly and quickly.

Please visit our website www.handegroup.com.cn for more product information or to find your loved woven technical products.



www.handegroup.com.cn



WOVEN COLLECTION

QUIET



JA07



JA57



JA94



SK01



SK02



SK04



SK06



SK08



SK09



SK10



SK11

IMAGINE



JM84

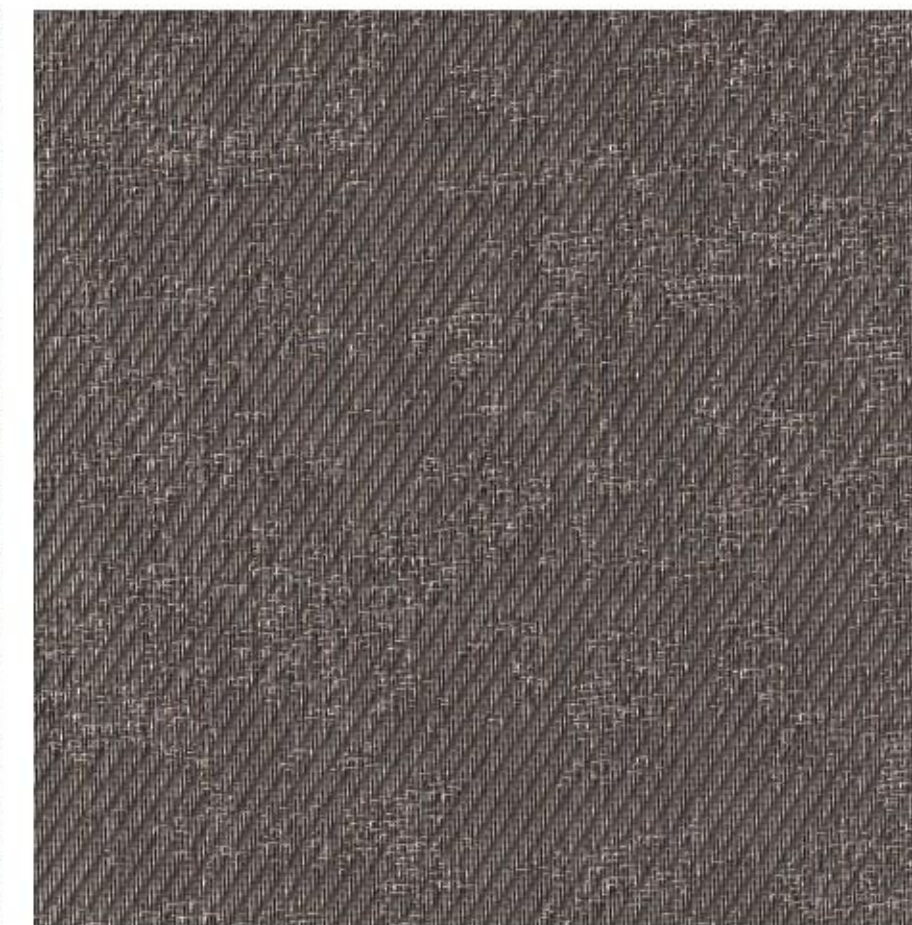

JM12



JM13

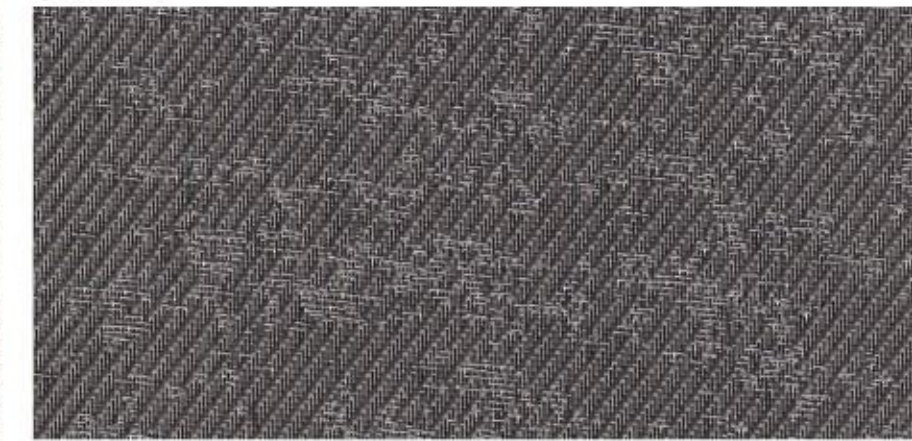

JM15



JM17



JM19



JM20



JM21

WOVEN COLLECTION

HOTEL



FG29



FG30



FG31



FG32



FG33



FG01



FG02

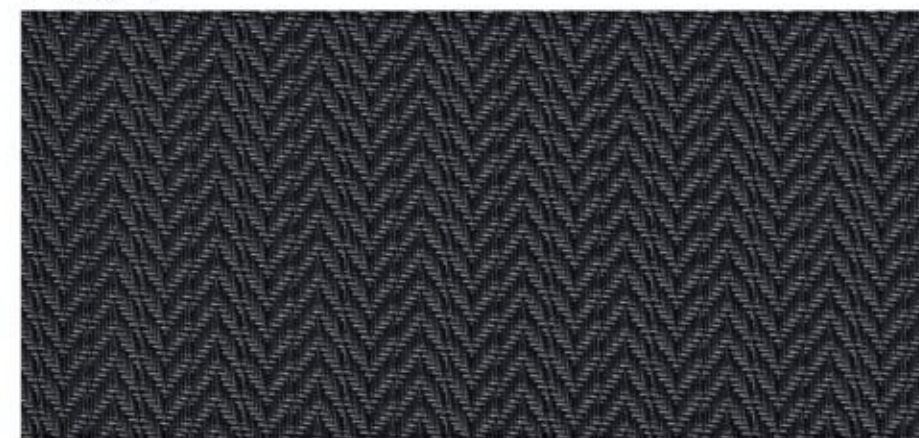

TG05

NATURE

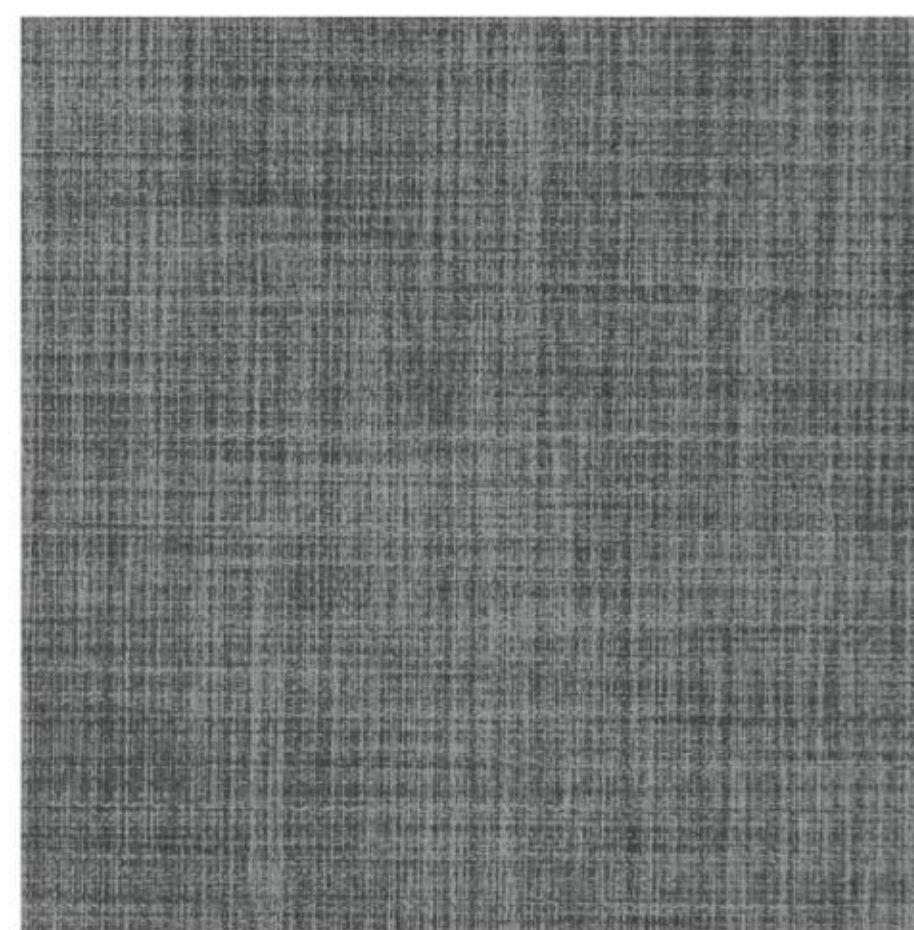

DT68



DT97



MZ32



MZ31

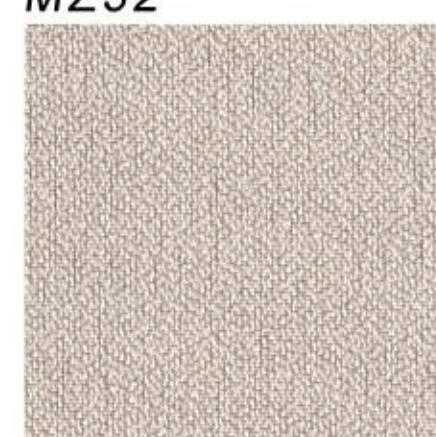

MZ07



OB69



OB68

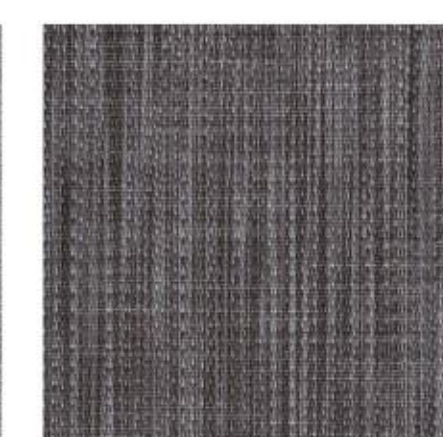

WM66



WM36

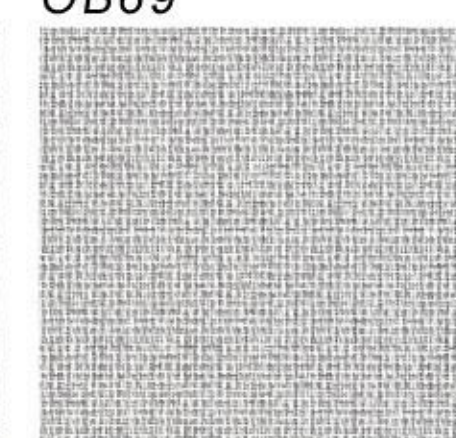

WM37

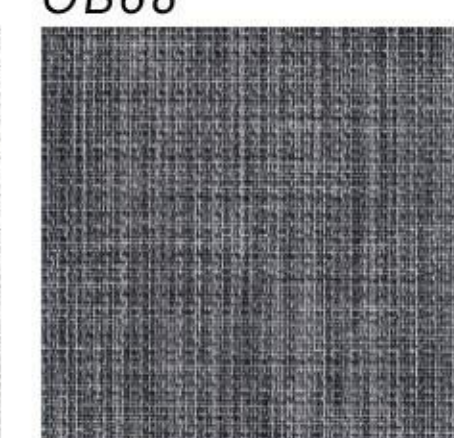

WM92

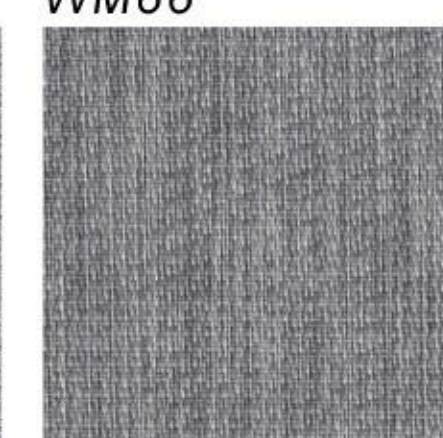

WM93

WOVEN COLLECTION

GARDEN



JM83



JM85



JM34



JM33

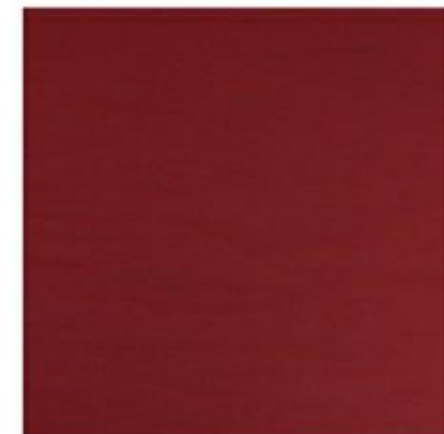

JM35



FL05



FL54



FL45



FL46



FL53



FL61



FL55

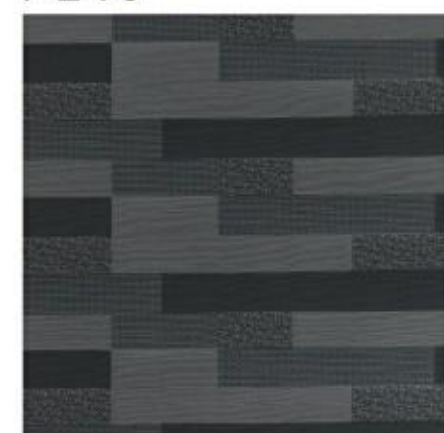

JS01



JS07

RIPPLE

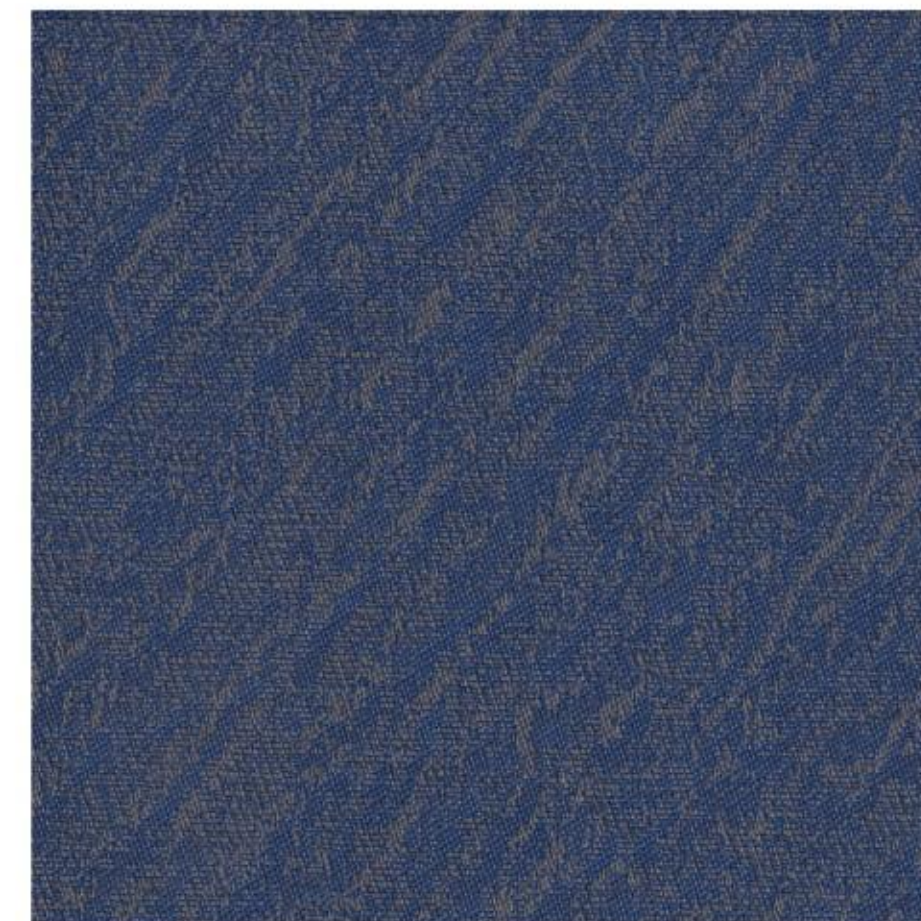

FL34



FL35



FL36

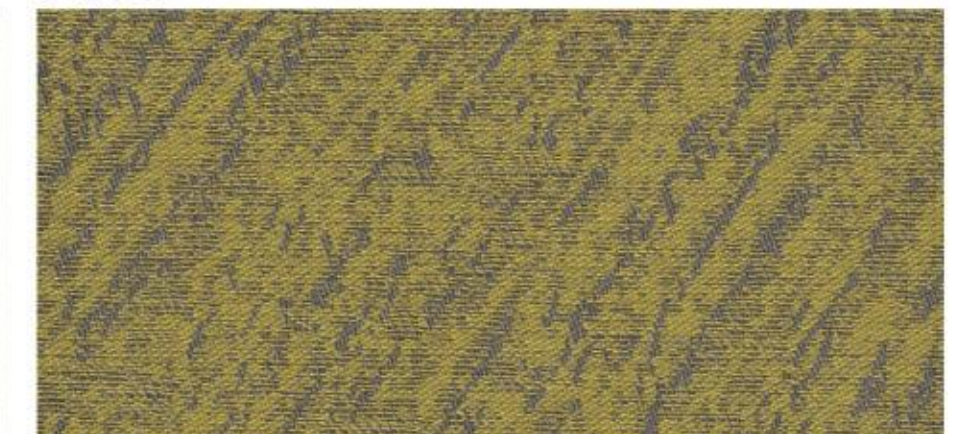

FL37



FL38



FL39



FL40



FL41



FL23



FL25

WOVEN COLLECTION

GRADIENT

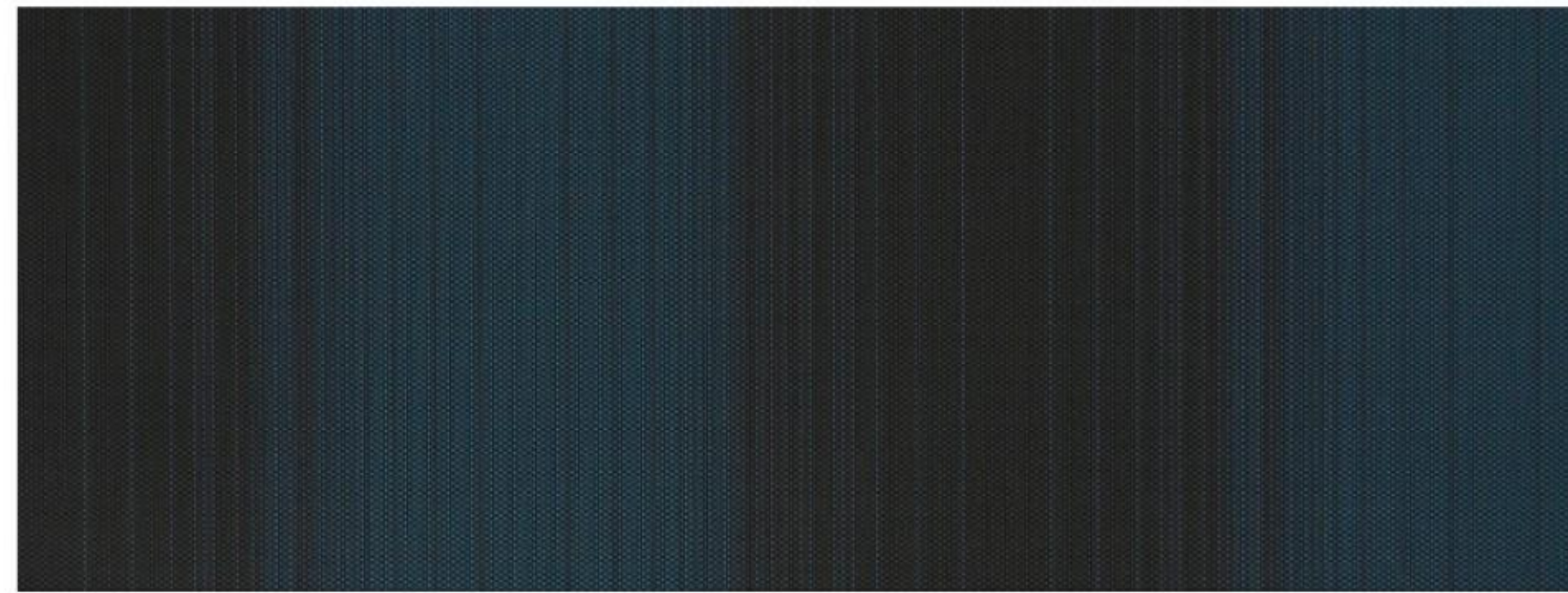

FD01



FD02

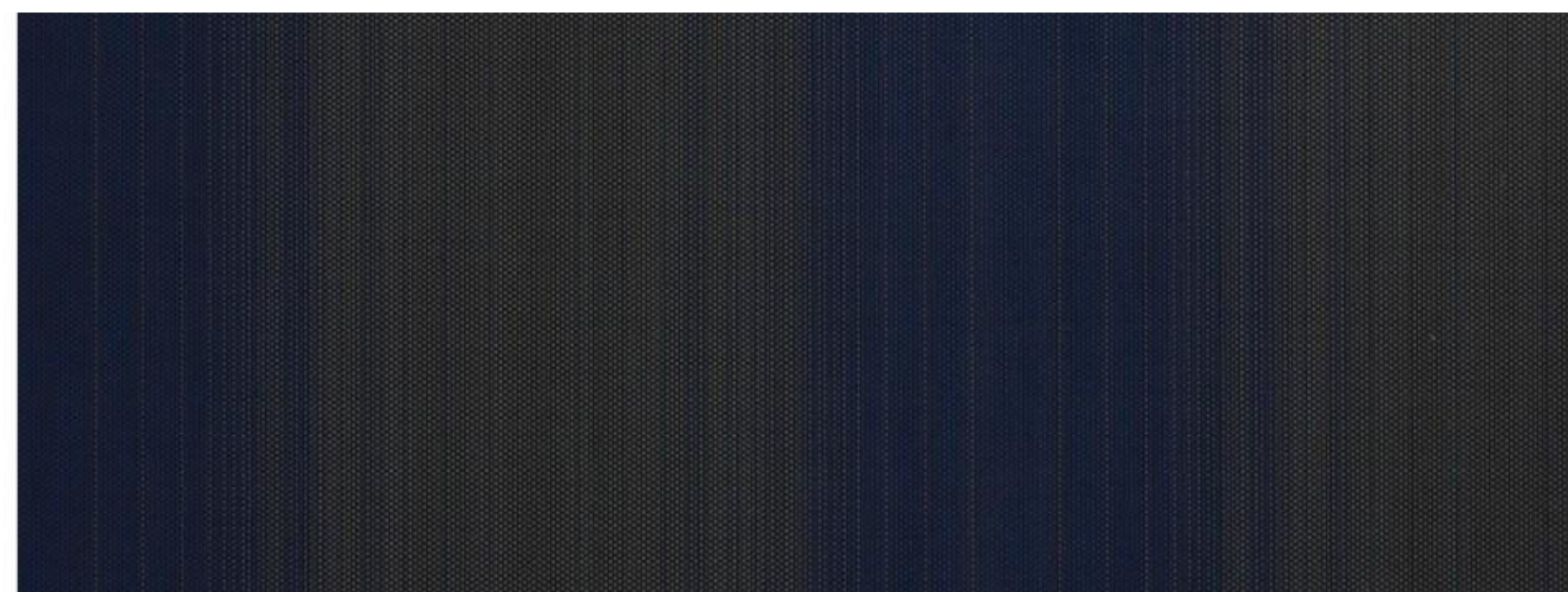

FD03

PRODUCT MIX

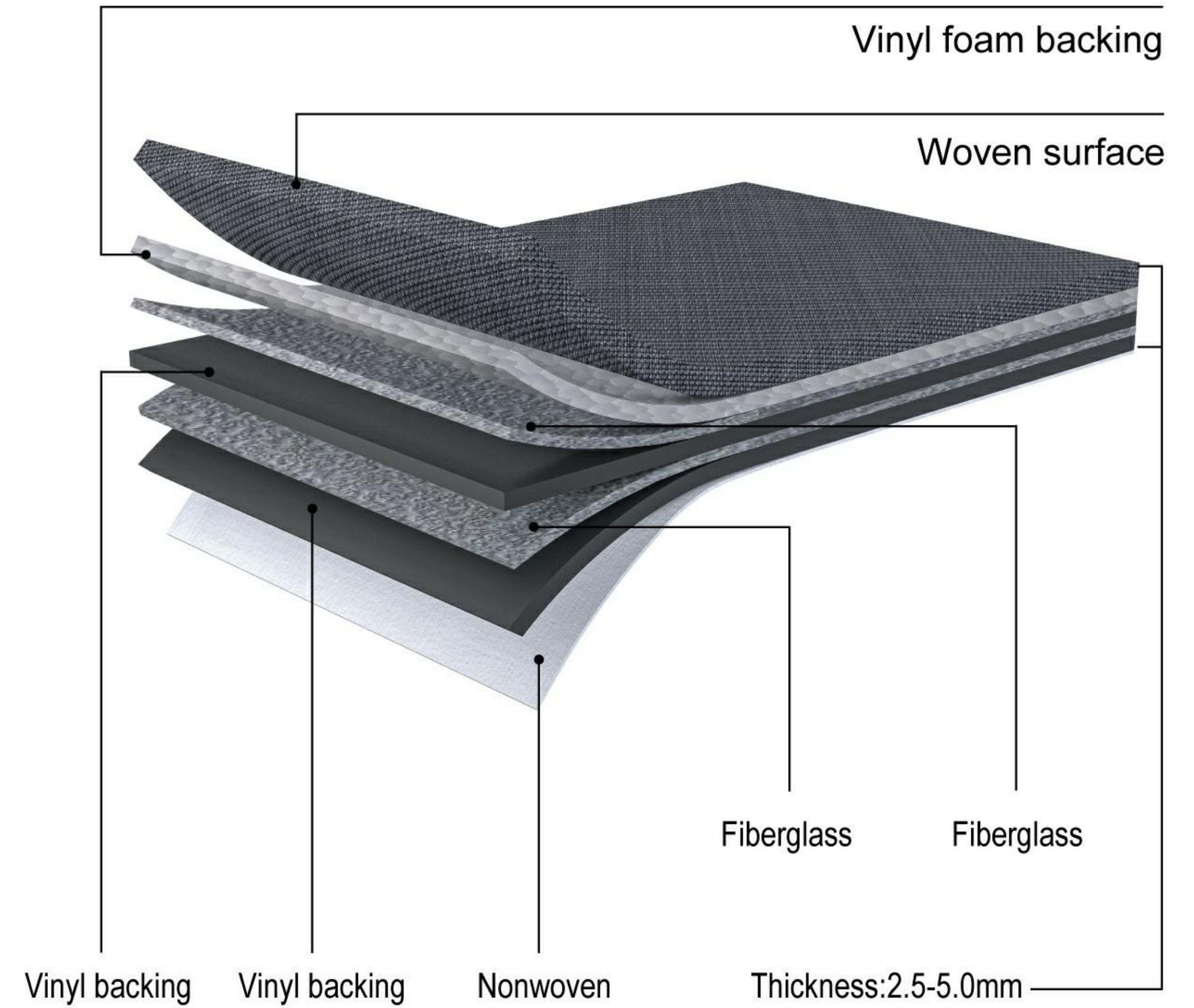

CERTIFICATIONS & SPECIFICATIONS



Technical Specifications	Standard	Rolls	Tiles
Warranty	-	10 years*	10 years*
Composition	93% Polyvinyl Chloride + 5% Glass Fiber + 2% Polyester / 2% Glass Fiber		
Total Weight	ISO 8543	3-8kg/m ²	3-12kg/m ²
Thickness	ISO 1765	2-5mm	2-8mm
Light Fastness	EN ISO 105-B02	8	8
Dimensional Stability	EN 986 ISO 2551	Fulfilled	Fulfilled
Castor Chair Suitability	EN 985:2002	Intensive Use	Intensive Use
Sound Insulation	ISO 10140	12 dB	14 dB
Thermal Resistance	ISO 8302	Suitable for Underfloor Heating	Suitable for Underfloor Heating
Static Electricity	EH 1815	0.1kv	0.1kv
Slip Resistance	EN13893	0.56	0.56
Reaction to Fire	EN 13501-1	Bfl-s1	Bfl-s1
	GB 8624	B1(C-s1, t0)	B1(C-s1, t0)
Critical radiant flux	ASTM E 648	Class 1	Class 1
Smoke density	ASTM E 662	<450	<450
Roll Width	-	200-320 cm	-
Roll Length	-	1000-2500 cm	-
Tile Dimensions	-	-	50 cm x 50 cm 20 pcs per box
CE Certificate	EN 14041	Pass	Pass
Level of Use	EN 1307:2014	Class 33 Heavy Commercial Use	Class 33 Heavy Commercial Use
Safety and Health	GB 18587	Pass	Pass

CERTIFICATIONS

