

BEIJING HUADE HYDRAULIC INDUSTRIAL GROUP CO.,LTD.	Pressure relief valve, type DB/DBW...50B/ (New Series)			RE25805 /12.2004
	Size 10 to 32	up to 35 MPa	up to 650 L/min	Replaces: RE25805/05.2001

Features:

- Subplate mounting
- Porting pattern to DIN 24 340, form E,ISO 6264 and CETOP-RP 121H
- Pipe connection
- Insert connection
- Three adjustment elements:
 - Rotary knob
 - Hex. head screw with protective cap
 - Lockable rotary knob with scale
- Solenoid operated unloading via built-in directional spool valve

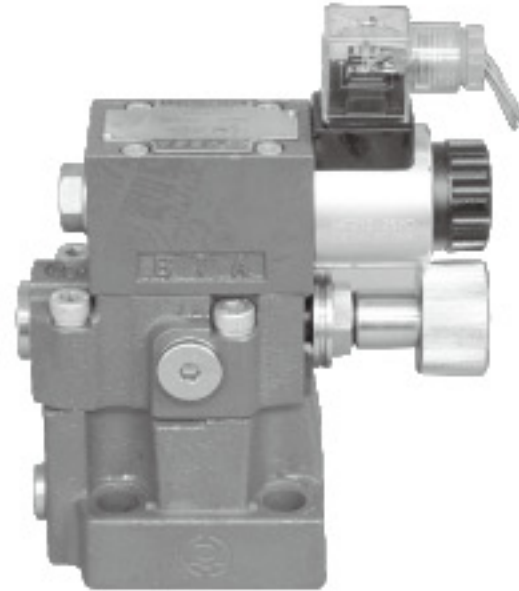

Function, section: type DB...

General

Types DB and DBW pressure valves are pilot operated pressure relief valves.

They are used for the limitation (DB) or limitation and solenoid actuated unloading (DBW) of the control pressure. The pressure relief valves (DB) consist mainly of the main valve (1) with main spool assembly (3) and pilot operated valve (2) with pressure adjustment element.

Pressure relief valve type DB:

The pressure present in port A acts on the main spool (3). At the same time pressure is applied via the control lines (6) and (7), which are fitted with orifices (4) and (5), on the spring loaded side of the main spool (3) and at the ball (8) in the pilot control valve (2). If the pressure in port A exceeds the valve set at the spring (9), the ball (8) opens against the spring (9).

The signal for this comes internally via the control lines (10) and (6) from port A. The pressure fluid on the spring loaded side of the main spool (3) now flows via the control line (7), orifice bore (11) and ball (8) into the spring chamber (12). In type DB...50B/... it flows internally via the control line (13) to tank, or in type DB..50/..Y.. externally via the control line (14). Due to the orifices (4) and (5) a pressure drop occurs at the main spool (3), the connection from port A to port B is open, Now the pressure fluid flows from port A to port B whilst maintaining the set operating pressure.

The pressure relief valve may be unloaded or switched over to a different pressure (second pressure stage) via port "X" (15).

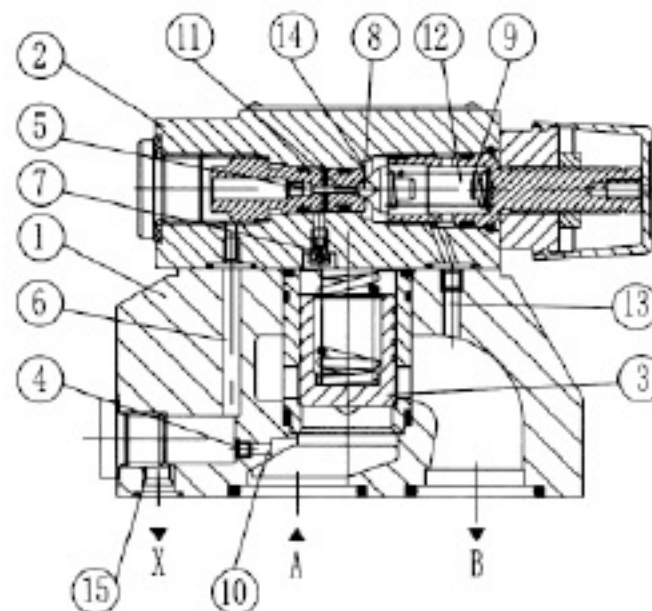

Type DBW...50B/...

Pressure relief valve type DBW

The function of this valve is basically same as the valve type DB.

The unloading at the main spool(3), however, is achieved by actuating the built-in directional valve(16).

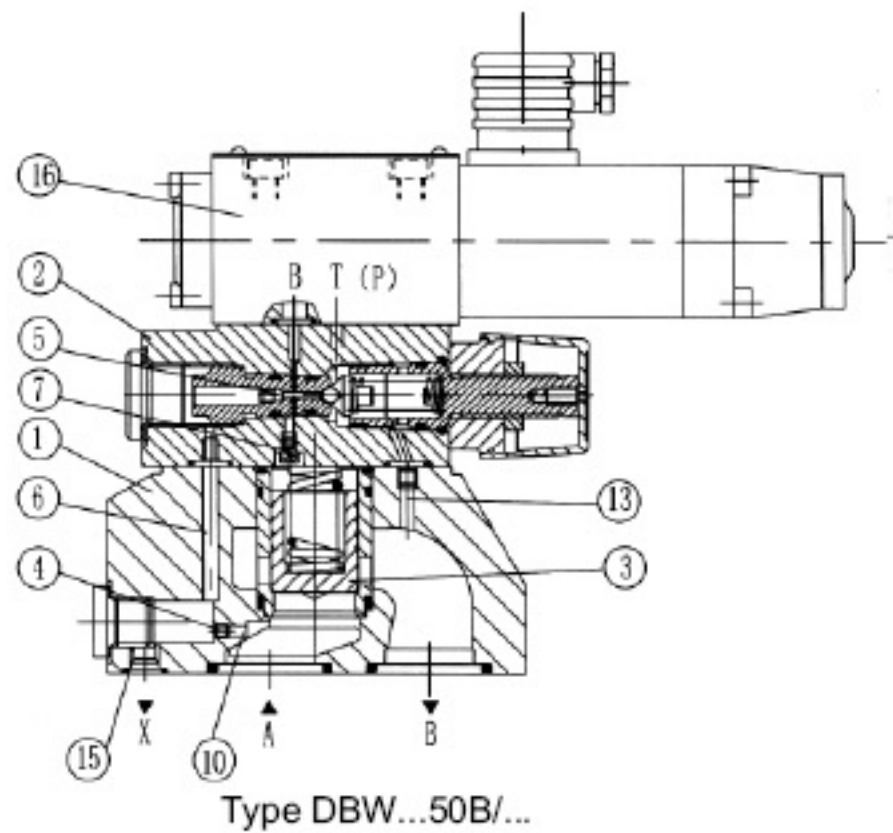

symbols

<p>DB ..-50B/..</p>	<p>DB ..-50B/..X.</p>	<p>DB ..-50B/..Y..</p>	<p>DB ..-50B/..XY..</p>
<p>DBW ..-50B/..</p> <p>Normally closed</p> <p>Normally open</p>	<p>DBW ..-50B/..X..</p> <p>Normally closed</p> <p>Normally open</p>	<p>DBW ..-50B/..Y..</p> <p>Normally closed</p> <p>Normally open</p>	<p>DBW ..-50B/..XY..</p> <p>Normally closed</p> <p>Normally open</p>

Technical data

General

Installation			optional				
Weight	Subplate mounting	DB (Kg)	DB10	DB15	DB20	DB25	DB30
		DBW (Kg)	2.6	-	3.5	-	4.4
		DBC (Kg)	3.8	-	4.7	-	5.6
		DBC10 or 30 (Kg)	1.2 (type DBWC add 1.2Kg)				
	Threading connection	DB..G.. (Kg)	1.5 (DBWC10 or 30 add 1.2Kg)				
		DBW..G.. (Kg)	5.3	5.2	5.1	5.0	4.8
		6.5	6.4	6.3	6.2	6.0	
Technical data for the directional valves			see WE6.../...				

Hydraulic technical data

Maximum operating pressure at ports A, B, X		(MPa)	up to 35.0				
Maximum back pressure at port Y	DB	(MPa)	up to 31.5				
	DBW.6A. (standard solenoids)	(MPa)	AC(DC) 10.0		AC(DC) 16.0		
	DBW.6B. (high-power solenoids)	(MPa)	AC(DC) 16.0				
Settable pressure	Minimum	(MPa)	flow dependent (see characteristic curves)				
	Maximum	(MPa)	Maximum 5.0, 10.0, 20.0, 31.5, 35.0				
Maximum flow			DB10	DB15	DB20	DB25	DB30
	Subplate mounting	(L/min)	250	-	500	-	650
	Threaded connections	(L/min)	250	500	500	500	650
Pressure fluid			Mineral oil (for NBR seal) or phosphate ester (for FPM seal)				
Pressure fluid temperature range		(°C)	-30 to + 80				
Viscosity range		(mm ² /s)	10 to 800				
Degree of contamination			NAS 1638 class 9.				

Characteristic curves (measured at $\nu = 41 \text{ mm}^2/\text{s}$ and $t = 50^\circ\text{C}$)

The characteristic curves were measured with external, at zero pressure, drain pilot oil.
 With internal pilot oil drain the inlet pressure increases by the outlet pressure present at port B.

Inlet pressure in relation to the flow

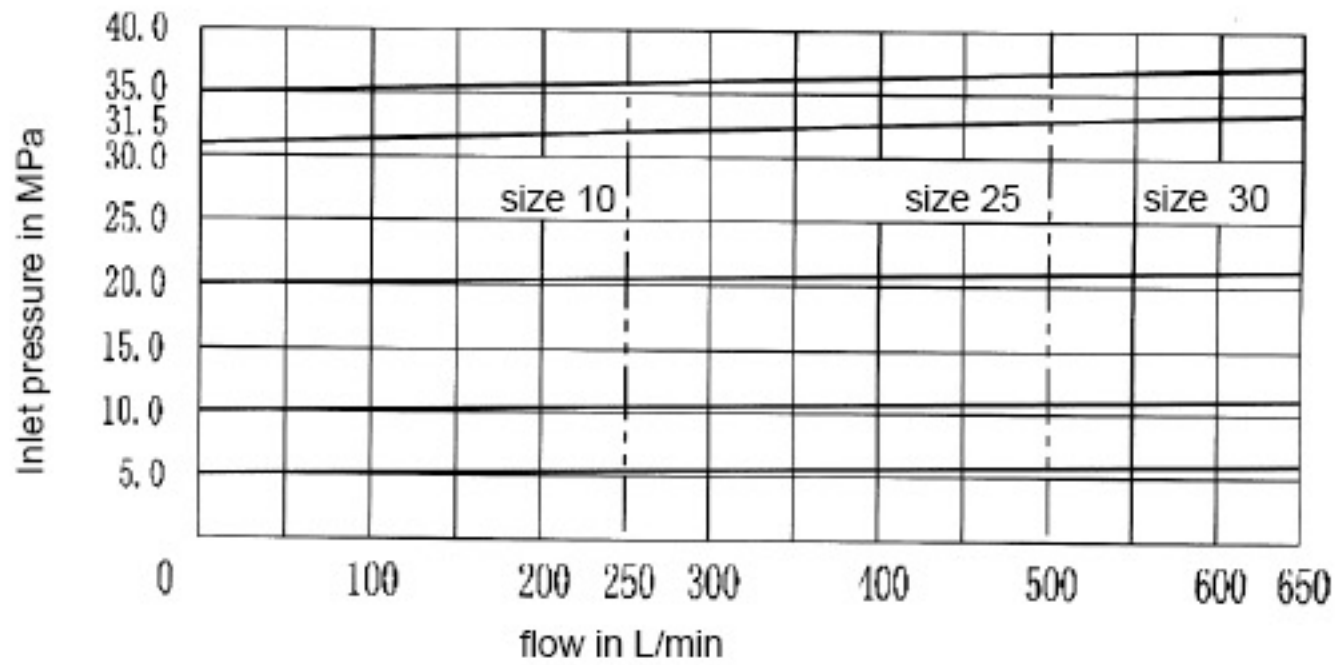

Minimum settable pressure and bypass pressure in relation to the flow
 Standard version

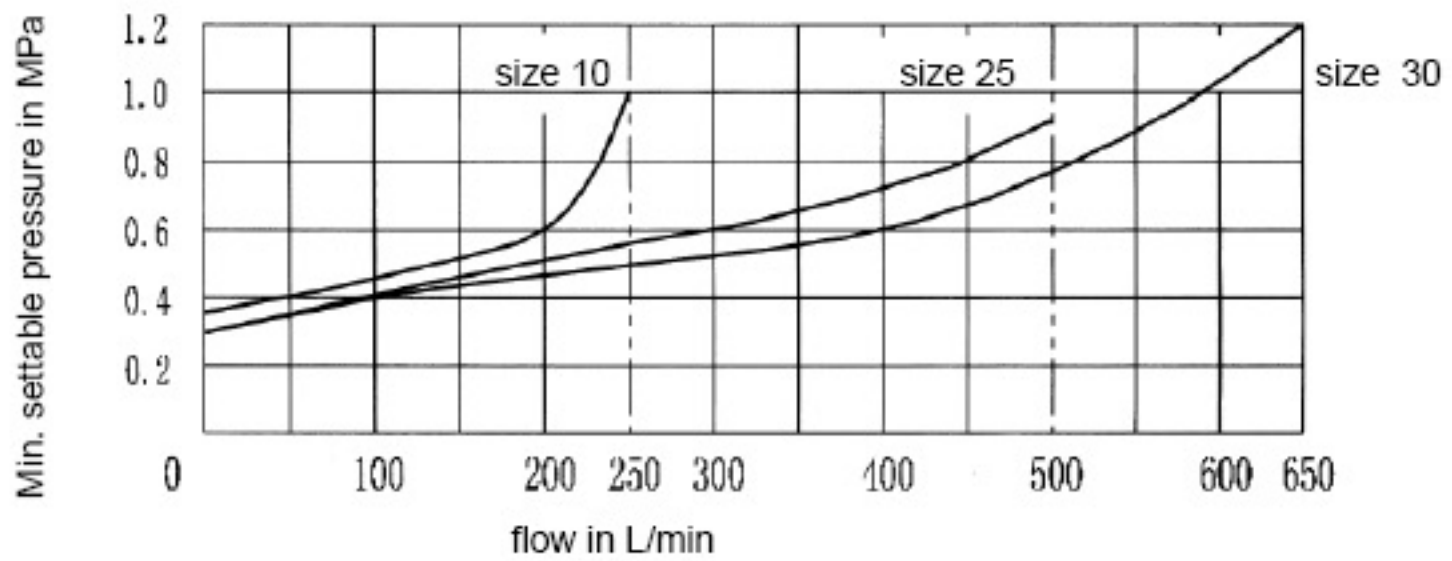

Minimum settable pressure and bypass pressure in relation to the flow
 Version "U"

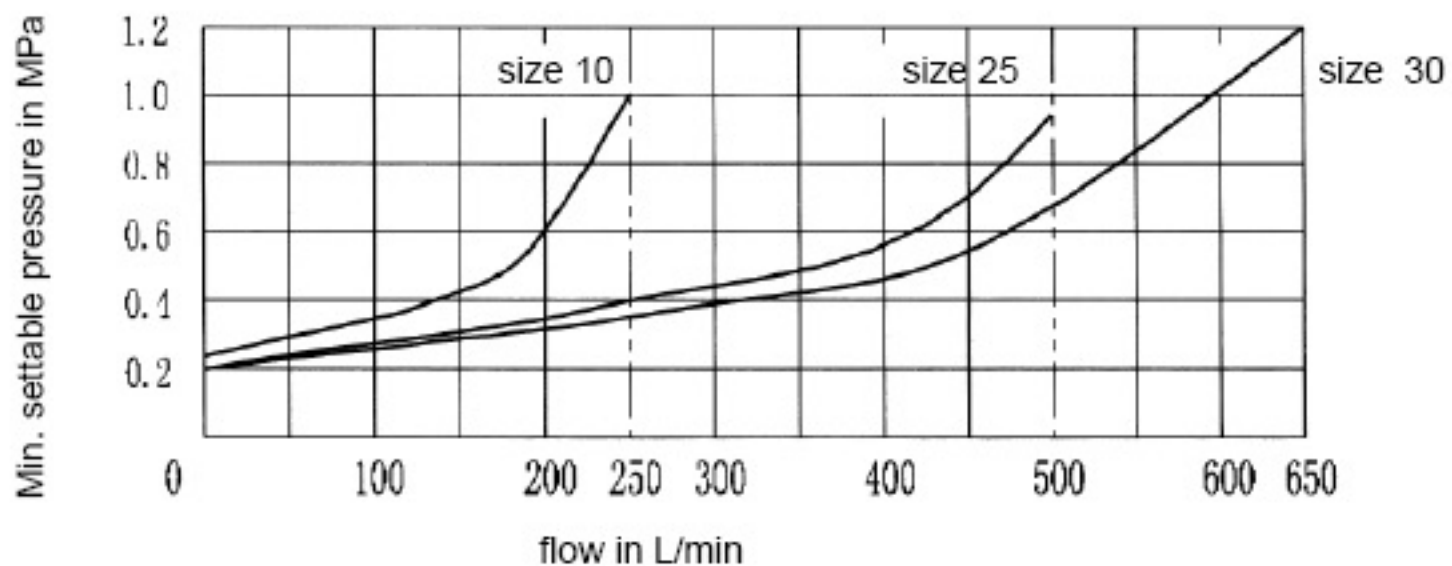

The characteristic curves are valid for outlet pressure $B = 0$ over the entire flow range!

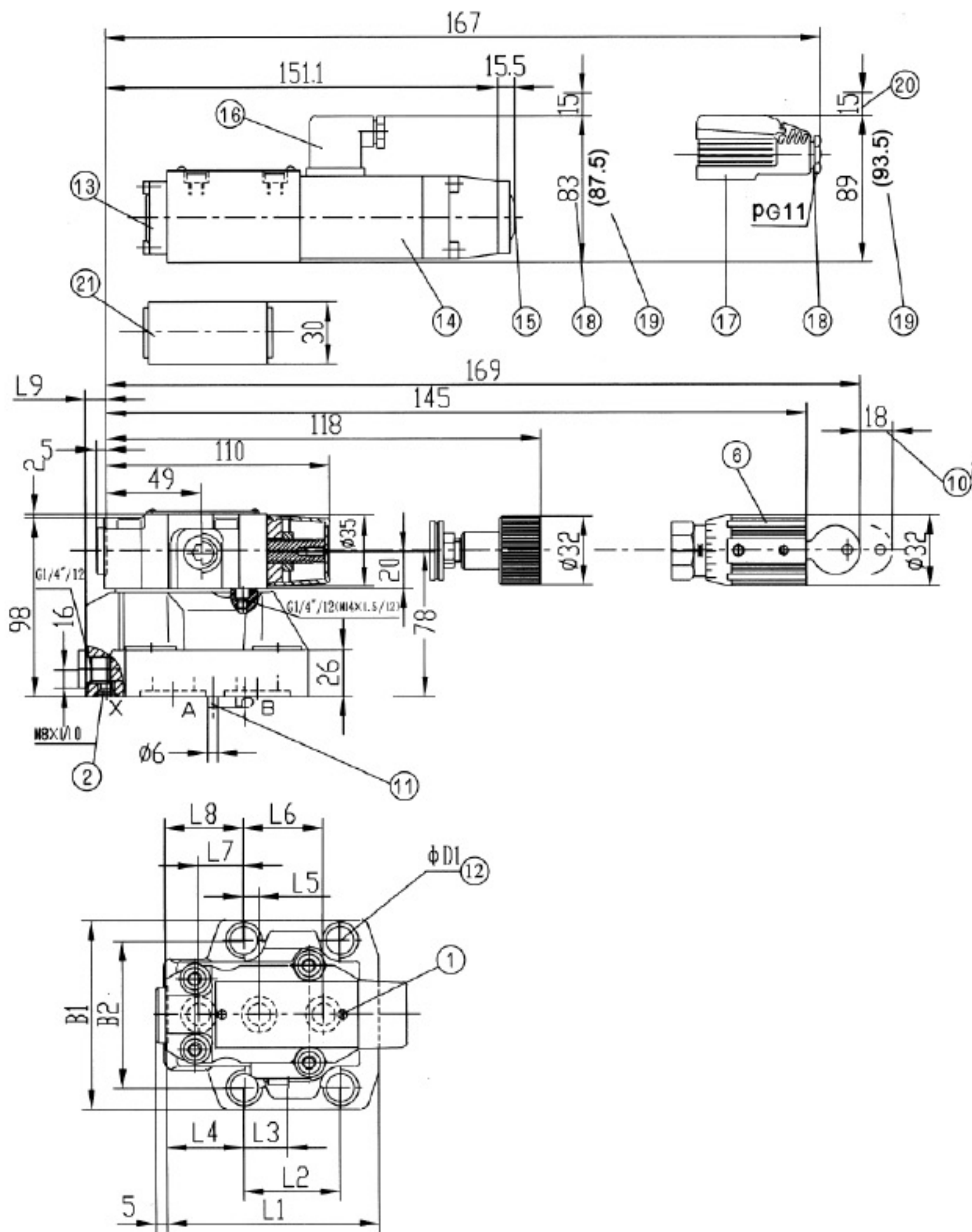

Type	L1	L2	L3	L4	L5	L6	L7	L8	L9	B1	B2	φD1	Ports A,B	Port Y
DB/DBW10	91	53.8	22.1	27.5	22.1	47.5	0	25.5	2	78	53.8	14	17.12 × 2.62	9.25 × 1.78
DB/DBW20	116	66.7	33.4	33.3	11.1	55.6	23.8	22.8	10.5	100	70	18	28.17 × 3.53	9.25 × 1.78
DB/DBW30	147.5	88.9	44.5	41	12.7	76.2	31.8	20	21	115	82.6	20	34.52 × 3.53	9.25 × 1.78

Pilot control valves with cartridge element (DBC 30) or without cartridge element (DBC).

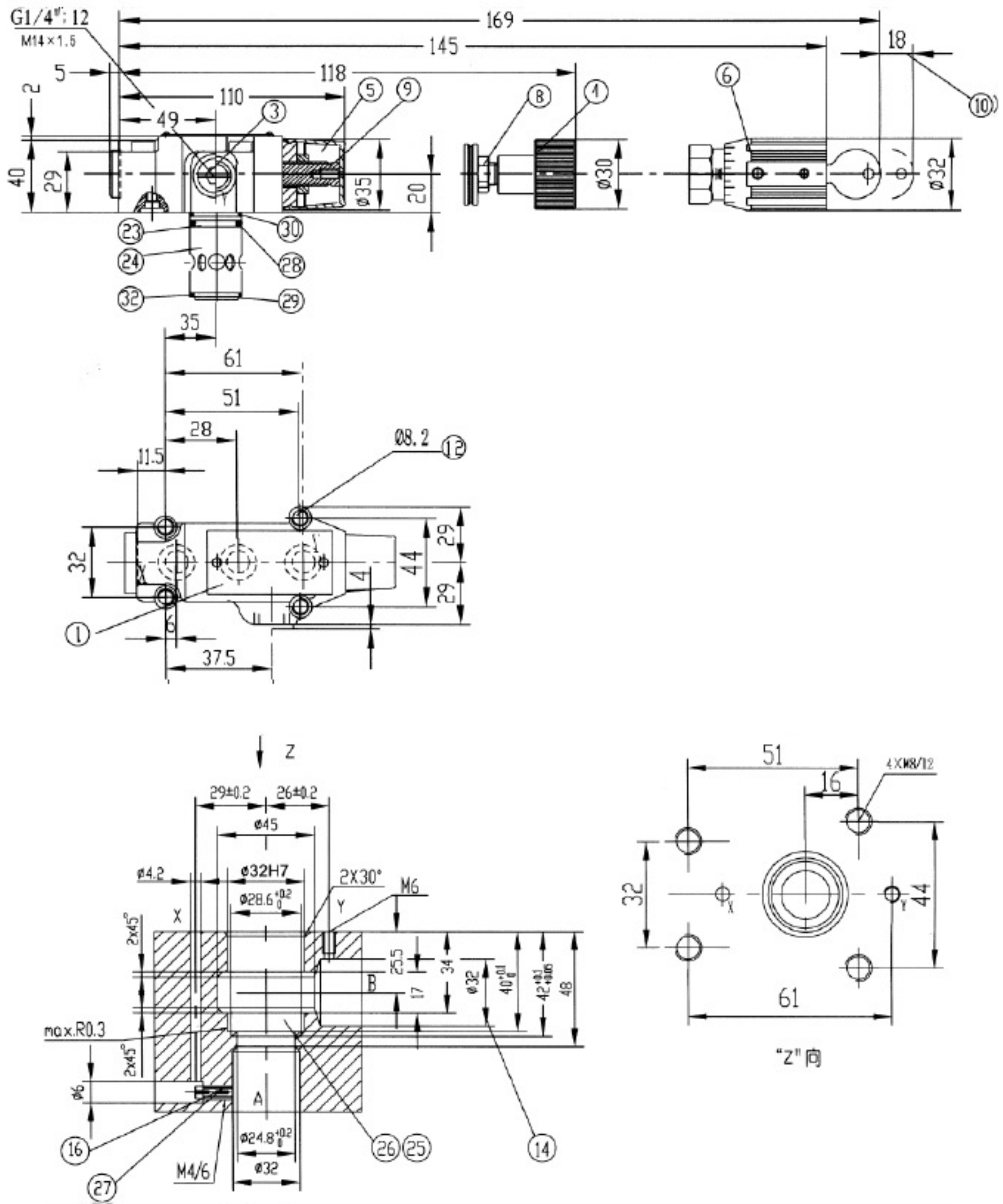

Item explanations

- | | |
|---------------------------------------------------------------------------------------------------------------------------------------------------------------------------------------------------------------------------------------------------------------------------------------------------------------------------------------------------------------------------------------------------------------------------------------------------------------------------------------------------------------------------------------------------------------------------------------------------------------------------------------------------------------------------------------------------------------------------------------------------------------------------------------------------------------------------|--------------------------------------------------------------------------------------------------------------------------------------------------------------------------------------------------------------------------------------------------------------------------------------------------------------------------------------------------------------------------------------------------------------------------------------------------------------------------------------------------------------------------------------------------------------------------------------------------------------------------------------------------------------------------------------------------------------------------------------------------------------------------------------------------------------------------------------------------------------------------------------------------------------------------------|
| <p>1 Nameplate
 2 Port X for external pilot oil supply
 3 Port Y for external pilot oil drain
 4 Adjustment element 1
 5 Adjustment element 2
 6 Adjustment element 3
 8 Lock nut 22 A/F
 9 Hexagon 10 A/F
 10 Space required to remove key
 11 Locating pin
 12 Valve fixing holes
 13 Directional spool valve WE6
 14 Solenoid "a"
 15 Hand override, optional
 16 Plug-in connector "Z4"
 17 Large plug-in connector "Z5" and "Z5L"
 18 The dimension of the standard solenoid "A"</p> | <p>19 The dimension of the high-power solenoid "B"
 20 Space required to remove plug-in connector
 21 Switching shock damping valve, optional
 22 Omitted with internal pilot oil drain
 23 O-ring 9.25X1.78
 24 Main spool assembly
 25 The Φ 32 bore may connect the Φ 45 bore at any position. Please take care that the connection hole X and the fixing holes are not damaged.
 26 Back-up ring and O-ring must be inserted into this bore before assembling the main spool.
 27 Cartridge element include orifice and main spool assembly
 28 O-ring 28x 1.8
 29 O-ring 27.3 x 2.4
 30 O-ring 28 x 2.65
 32 Back-up ring 28.4X32X0.8</p> |
|---------------------------------------------------------------------------------------------------------------------------------------------------------------------------------------------------------------------------------------------------------------------------------------------------------------------------------------------------------------------------------------------------------------------------------------------------------------------------------------------------------------------------------------------------------------------------------------------------------------------------------------------------------------------------------------------------------------------------------------------------------------------------------------------------------------------------|--------------------------------------------------------------------------------------------------------------------------------------------------------------------------------------------------------------------------------------------------------------------------------------------------------------------------------------------------------------------------------------------------------------------------------------------------------------------------------------------------------------------------------------------------------------------------------------------------------------------------------------------------------------------------------------------------------------------------------------------------------------------------------------------------------------------------------------------------------------------------------------------------------------------------------|

Subplates for:

DB/DBW10	DB/DBW20	DB/DBW30	DBC/DBWC
G545/01 (G3/8")	G408/01 (G3/4")	G410/01 (G11/4")	G51/01 (G1/4")
G545/02 (M18 × 1.5)	G408/02 (M27 × 2)	G410/02 (M42 × 2)	G51/02 (M14 × 1.5)
G546/01 (G1/2")	G409/01 (G1")	G411/01 (G11/2")	
G546/02 (M22 × 1.5)	G409/02 (M33 × 2)	G411/02 (M48 × 2)	

See page 148, 149

Valve fixing screws for:

Types DB/DBW 10

4-M12 x 50 -10.9(GB/T70.1-2000); $M_A = 130$ Nm

Types DB/DBW 20

4-M16 x 50 -10.9(GB/T70.1-2000); $M_A = 310$ Nm

Types DB/DBW 30

4-M18 x 50 -10.9(GB/T70.1-2000); $M_A = 430$ Nm

Types DBC/DBWC, DBT/DBWT

Types DBC 10/DBWC 10 and types DBC 30/DBWC 30

4-M8 x 40 -10.9(GB/T70.1-2000); $M_A = 37$ Nm

Required surface finish
of mating piece

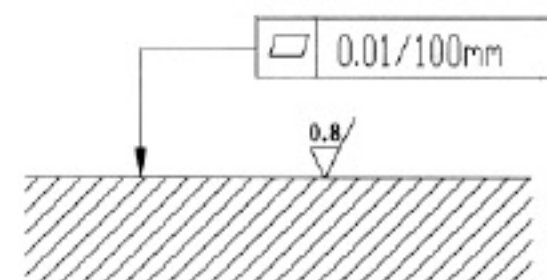

NOTICE

1. The fluid must be filtered. Minimum filter fineness is 20 μm .
2. The tank must be sealing up and an air filter must be installed on air entrance.
3. Products without subplate when leaving factory, if need them, please ordering specially.
4. Valve fixing screws must be high intensity level (class 10.9). Please select and use them according to the parameter listed in the sample book.
5. Roughness of surface linked with the valve is required to $\frac{0.8}{\nabla}$.
6. Surface finish of mating piece is required to 0.01/100mm.