

BEIJING HUADE HYDRAULICS INDUSTRIAL GROUP CO.,LTD.	2-way flow control valve Type 2FRM 6			RC:28160/12.2004
	Size 6	up to 31.5MPa ¹⁾	up to 25 L/min	Replaces: RC28160/05.2001

Features:

- External closing of the pressure compensator, optional
- Check valve, optional
- Rotary knob with scale
- Lockable, optional

1) When used in conjunction with a rectifier plate up to 21 MPa



Function, section:

General:

The flow control valve type 2 FRM is a 2-way flow control valve. It is used for maintaining a constant flow, independent of pressure and temperature. The valve basically comprises of housing (1), rotary knob (2), orifice (3), pressure compensator (4) and an optional check valve.

Flow control valve type 2FRM 6 B..-20B/M

(without external closing, without check valve)

Flow from port A to B is throttled at throttle position (5). The throttle cross-section is varied by turning rotary knob (2). In order to keep the flow constant, independent of pressure, a pressure compensator (4) is fitted in port B downstream of the throttle position (5). The compression spring (6) presses orifice (3) and pressure compensator (4) outwards against their respective stops and thus keeps pressure compensator (4) in the open position when there is no flow through the valve. When fluid flows through the valve, the pressure acting in port A applies a force to pressure compensator (4) via orifice (7). The pressure compensator (4) moves into the compensating position until the forces balance. If the pressure in port A rises, pressure compensator (4) moves in the closing direction, until a balance of forces is once more attained. Due to this continuous compensating action of the pressure compensator, a constant flow is obtained. In order to control a flow through the valve in both directions, a rectifier sandwich plate type Z4S 6 may be fitted below this flow control valve.

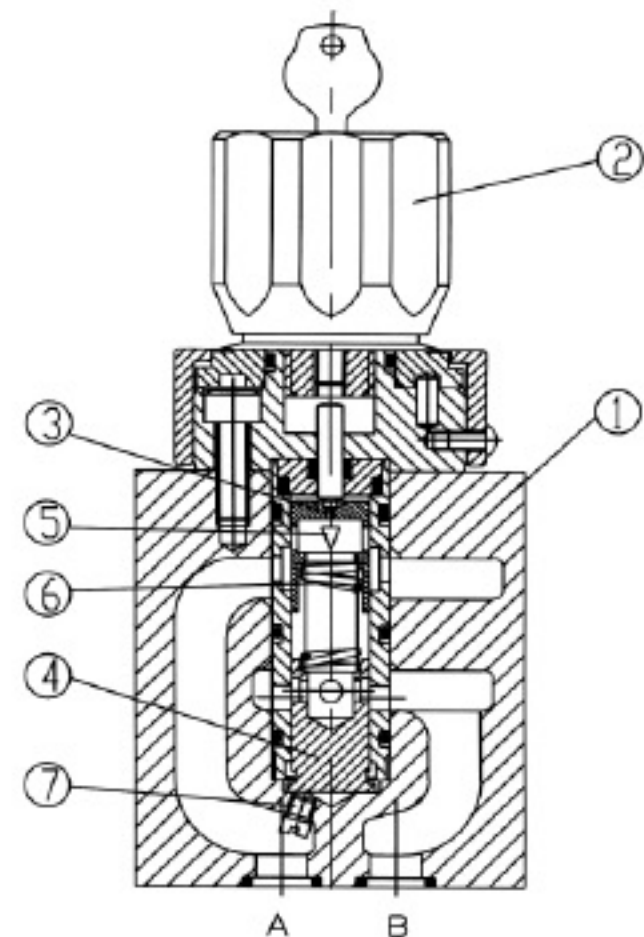

Type 2FRM6B36-20B/...M...

Type 2FRM 6 A..-20B/..R

The function of this valve is basically the same as that of valve type 2FRM 6 B..-20B/..M.

However, this type of flow control valve is provided with an external port permitting the pressure compensator (4) to be connected to via port P(11) . The external pressure acting in port P(11) via orifice (10) holds pressure compensator (4) closed against the force of compression spring (6). When the connected directional valve (9) is actuated to permit flow from P to B, closed loop control is achieved as with type 2 FRM 6 B. Thus a jump on start-up is avoided.

This version with external closing of the compensator may only be used for meter-in control.

Free return flow from port B to A is via check valve (8).

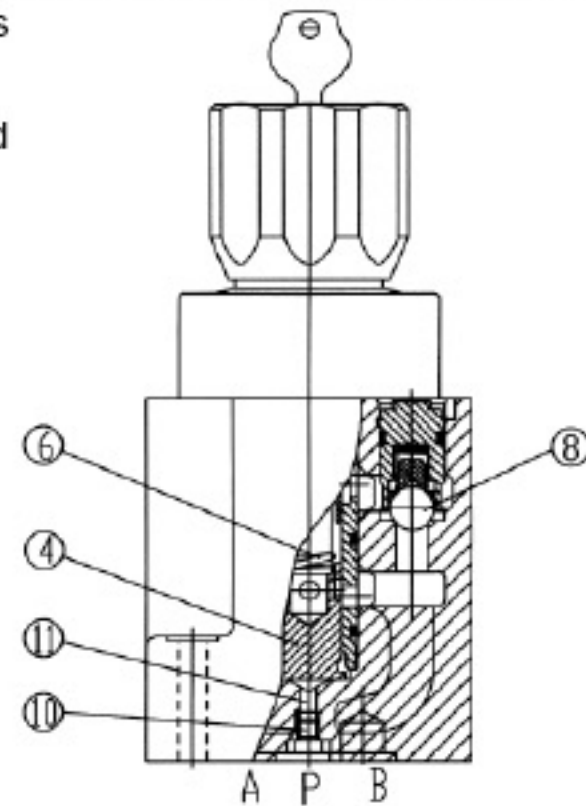
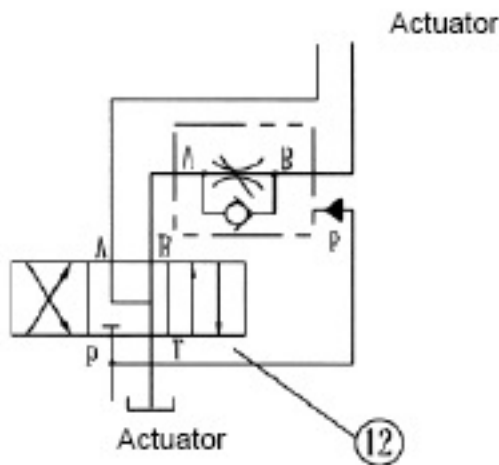

Symbols: 2-way flow control valves (simplified, detailed)

<p>Flow control valve: simplified (without check valve; without external closing)</p> <p>Type 2FRM6B..-20B/..M</p>	<p>Flow control valve: simplified (with check valve; without external closing)</p> <p>Type 2FRM6B..-20B/..R</p>	<p>Flow control valve: simplified (without check valve; with external closing)</p> <p>Type 2FRM6A..-20B/..M</p>	<p>Flow control valve: simplified (with check valve; with external closing)</p> <p>Type 2FRM6A..-20B/..R</p>
<p>Flow control valve: detailed (without check valve; without external closing)</p> <p>Type 2FRM6B..-20B/..M</p>	<p>Flow control valve: detailed (without check valve; with external closing)</p> <p>Type 2FRM6A..-20B/..M</p>		
<p>Flow control valve: detailed (with check valve; without external closing)</p> <p>Type 2FRM6B..-20B/..R</p>	<p>Flow control valve: detailed (with check valve; with external closing)</p> <p>Type 2FRM6A..-20B/..R</p>		

Ordering details: 2-way flow control valve

2FRM6 -20 B / *

With external closing of the pressure compensator (repression of jump at start) = A
Without external closing of the pressure compensator = B

Further details in clear text

Lockable rotary knob with scale = 3
Rotary knob with scale = 7

No code = Mineral oil
V = Phosphate ester (other seals on request)

R = with check valve
M = without check valve

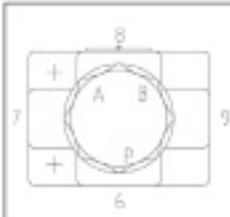

Zero position labels at port P=6
Zero position labels at port A=7
Zero position labels at port T=8
Zero position labels at port B=9

	Flow (A to B)
0.2 Q =	up to 0.2 L/min
0.6 Q =	up to 0.6 L/min
1.5 Q =	up to 1.5 L/min
3 Q =	up to 3.0 L/min
6 Q =	up to 6.0 L/min
10 Q =	up to 10.0 L/min
16 Q =	up to 16.0 L/min
25 Q =	up to 25.0 L/min

Series 20 to 29(20 to 29: unchanged installation and connection dimensions) = 20

Technology of Beijing Huade Hydraulic =B

Technical data: 2-way flow control valve (for applications outside these parameters, please consult us!)

Pressure fluid	Mineral oil(for NBR seal) or Phosphate ester (for FPM seal)						
Pressure fluid temperature range (°C)	-30 to +80						
Viscosity range (mm ² /s)	10 to 800						
Flow q _v max (L/min)	1.5	3.0	6.0	10.0	16.0	25.0	
Flow q _v min to 10MPa (L/min)	0.015	0.015	0.025	0.05	0.07	0.1	
Flow q _v min to 31.5MPa (L/min)	0.025	0.025	0.025	0.05	0.07	0.1	
Pressure difference Δp for free return flow B → A (MPa)	0.1	0.12	0.17	0.25	0.38	0.66	
Minimum pressure difference (MPa)	0.6 to 1.2						
Pressure stability up to Δp = 31.5 MPa (%)	± 2 (Qmax)						
Maximum operating pressure at port A (MPa)	to 31.5						
Contamination (μm)	25 (Q < 5L/min) 10 (Q < 0.5L/min)						
Weight (Kg)	approx 1.3						

Attention!

The pressure loss from P (at the inlet of the directional valve) to A (at the inlet of the flow control valve) is noticeable at low flows.

Characteristic curves:(measured at $v = 41 \text{ mm}^2 / \text{s}$ and $t = 50^\circ\text{C}$)

Flow in relationship to the scale setting (flow control from A to B)

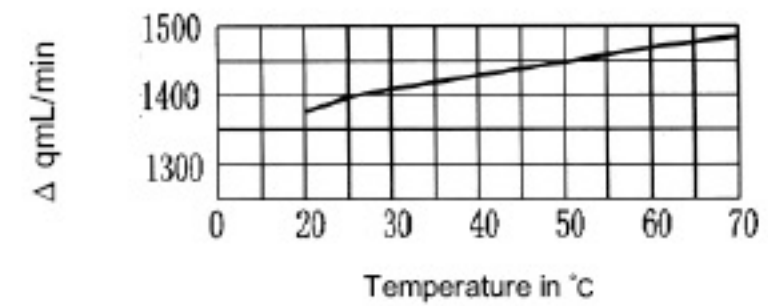
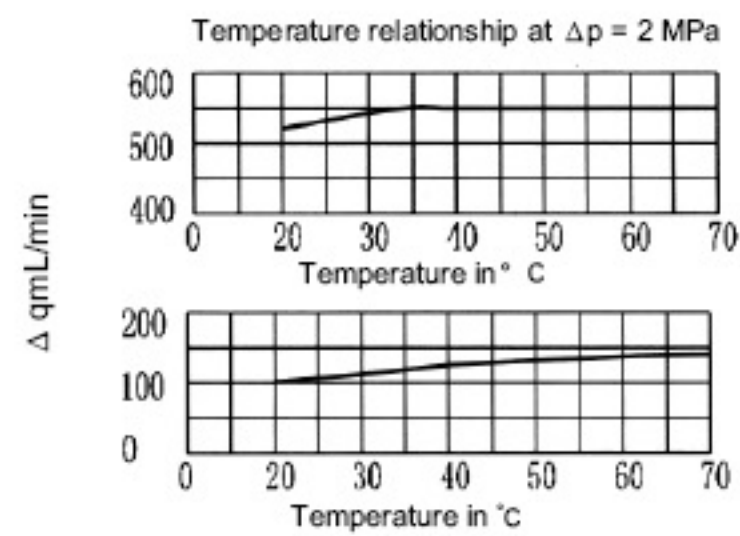
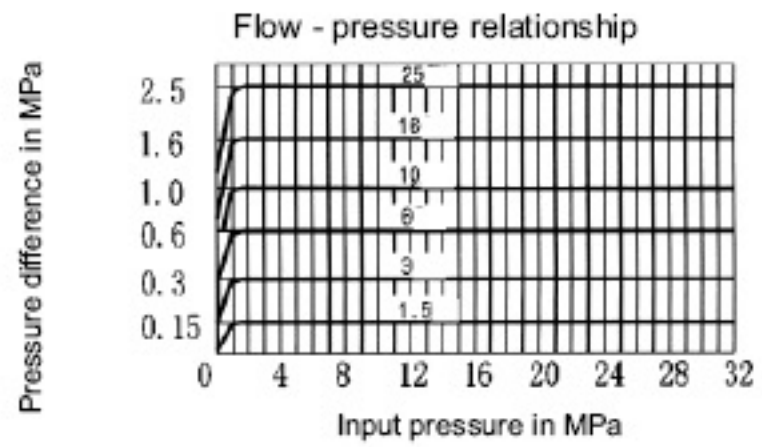
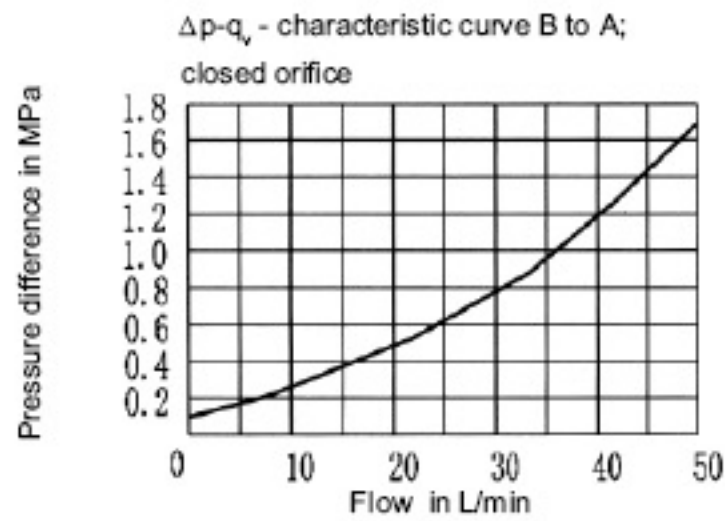
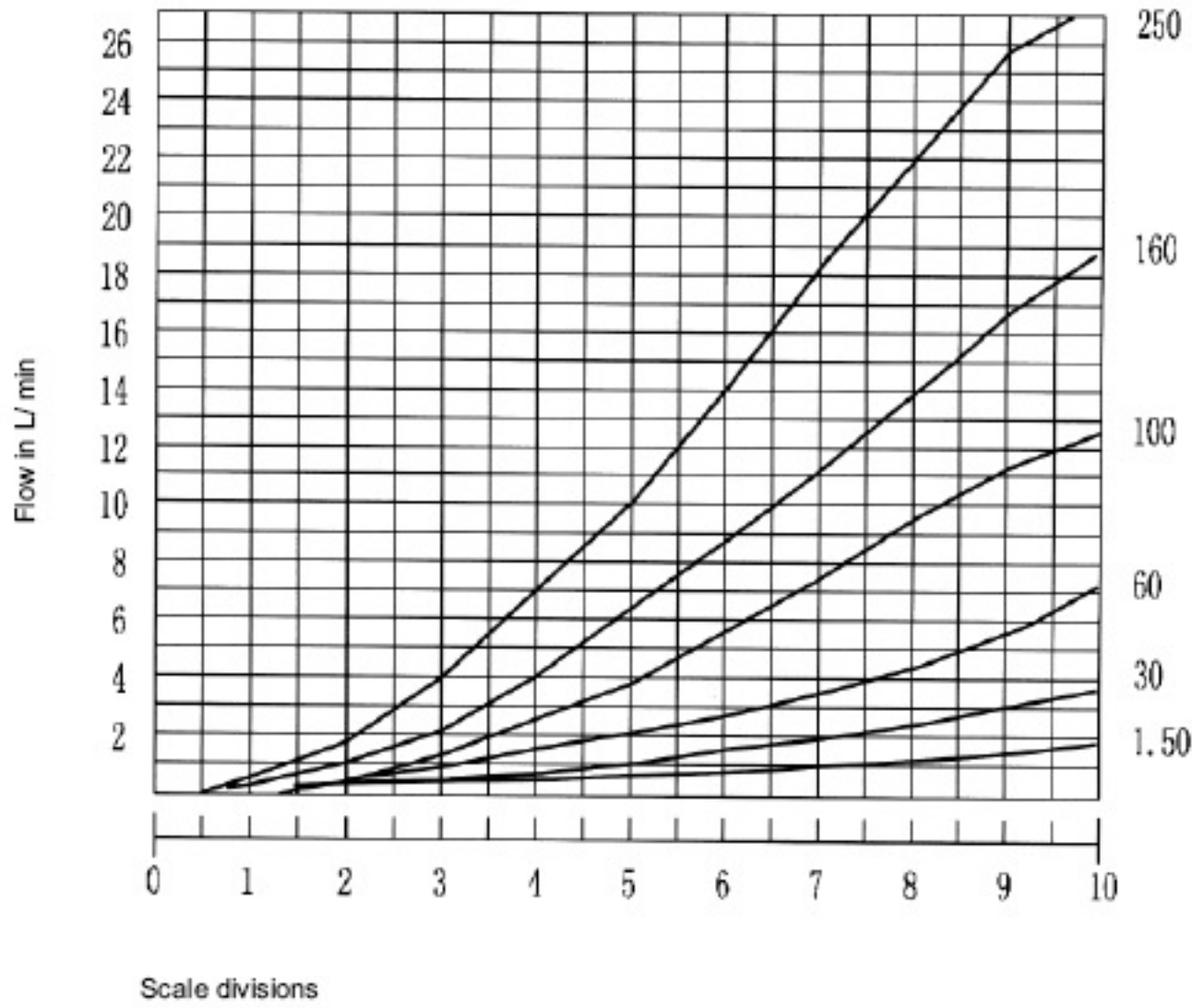

Unit dimensions:

(Dimensions in mm)

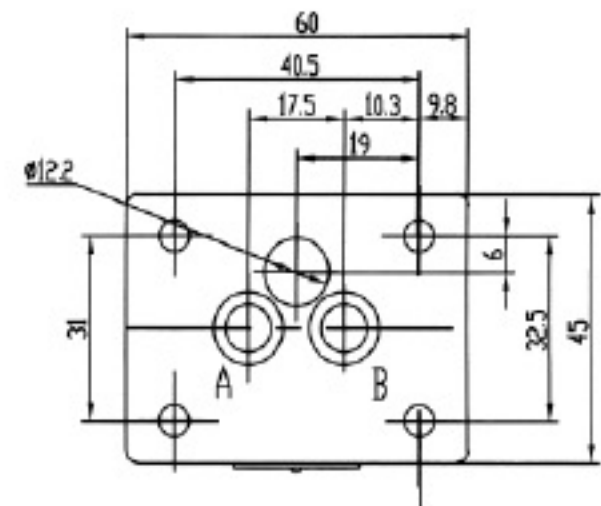
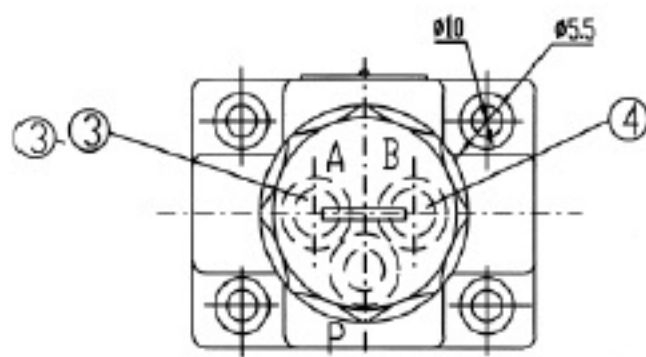
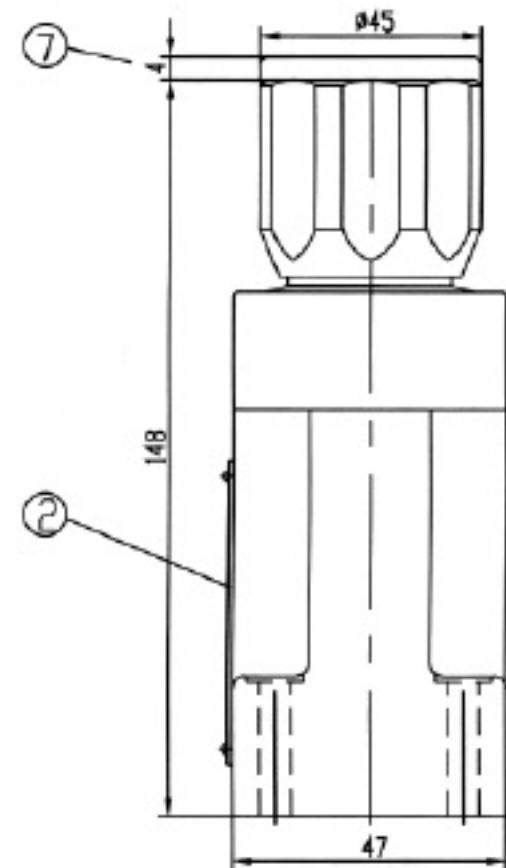
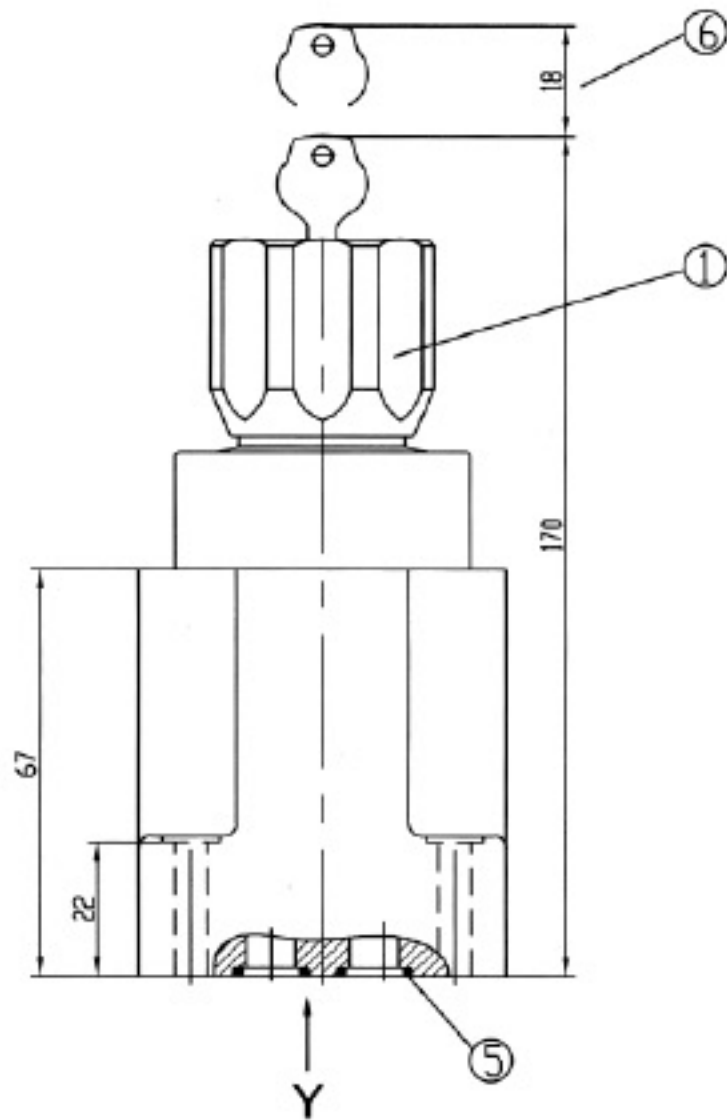

View "Y" Type 2FRM6B

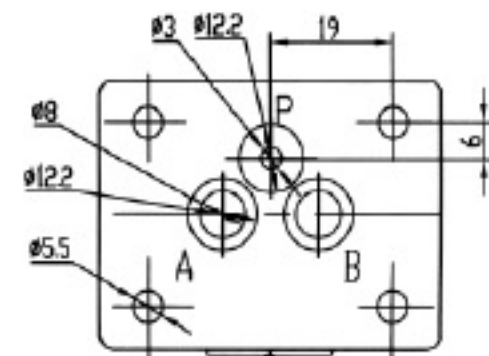

View "Y" Type 2FRM6A

- 1 Lockable rotary knob with scale
- 2 Nameplate
- 3 Inlet "A"
- 4 Outlet "B"
- 5 O-ring 9.25 x 1.78 for ports A, B, P and T
- 6 Space required to remove key
- 7 Rotary knob with scale (adjustment element "7")

Subplates: see page 68

G341/01 (G1/4")	G341/02 (M14x1.5)
G342/01 (G3/8")	G342/02 (M18x1.5)
G502/01 (G1/2")	G502/02 (M22x1.5)

Notice

1. The fluid must be filtered. Minimum filter fineness is 20 μm .
2. The tank must be sealing up and an air filter must be installed on air entrance.
3. Products without subplate when leaving factory, if need them, please ordering specially.
4. Valve fixing screws must be high intensity level (class 10.9). Please select and use them according to the parameter listed in the sample book.
5. Roughness of surface linked with the valve is required to $\frac{0.8}{\nabla}$.
6. Surface finish of mating piece is required to 0.01/100mm.