

BEIJING HUADE HYDRAULIC INDUSTRIAL GROUP CO.,LTD.	2-way flow control valve,Type 2FRM			RE:28138/12.2004
	Size 5	up to 21MPa	up to 15 L/min	Replaces: RE28138/05.2001

Features:

- Porting pattern to DIN 24 340, from A,ISO 4401 and CETOP-RP 121H
- Pressure compensator stroke limiter, optional
- Decrease of start-up jump
- Flow control in both directions using a rectifier sandwich plate
- Lockable rotary knob



Function , section

The 2FRM flow valve is a 2-way flow control valve. It mainly consists of housing(1), setting element(2), orifice(3), pressure compensator(4) optionally with stroke limiter as well as check valve(5) and is used for the throttling of a flow at low pressure and temperature dependency.

The throttling cross section is set by the rotation of the curve bolt(7). To keep the flow constant independent from the pressure at the throttling point(8) a pressure compensator (4) is connected. The temperature independence is the result of the throttling point being constructed as an orifice.

The free flow return from B to A is via the check valve(5).

In order to reach a controlled through flow of the valve in either direction there is the possibility to install a rectifier sandwich plate type Z4S below the flow control valve.

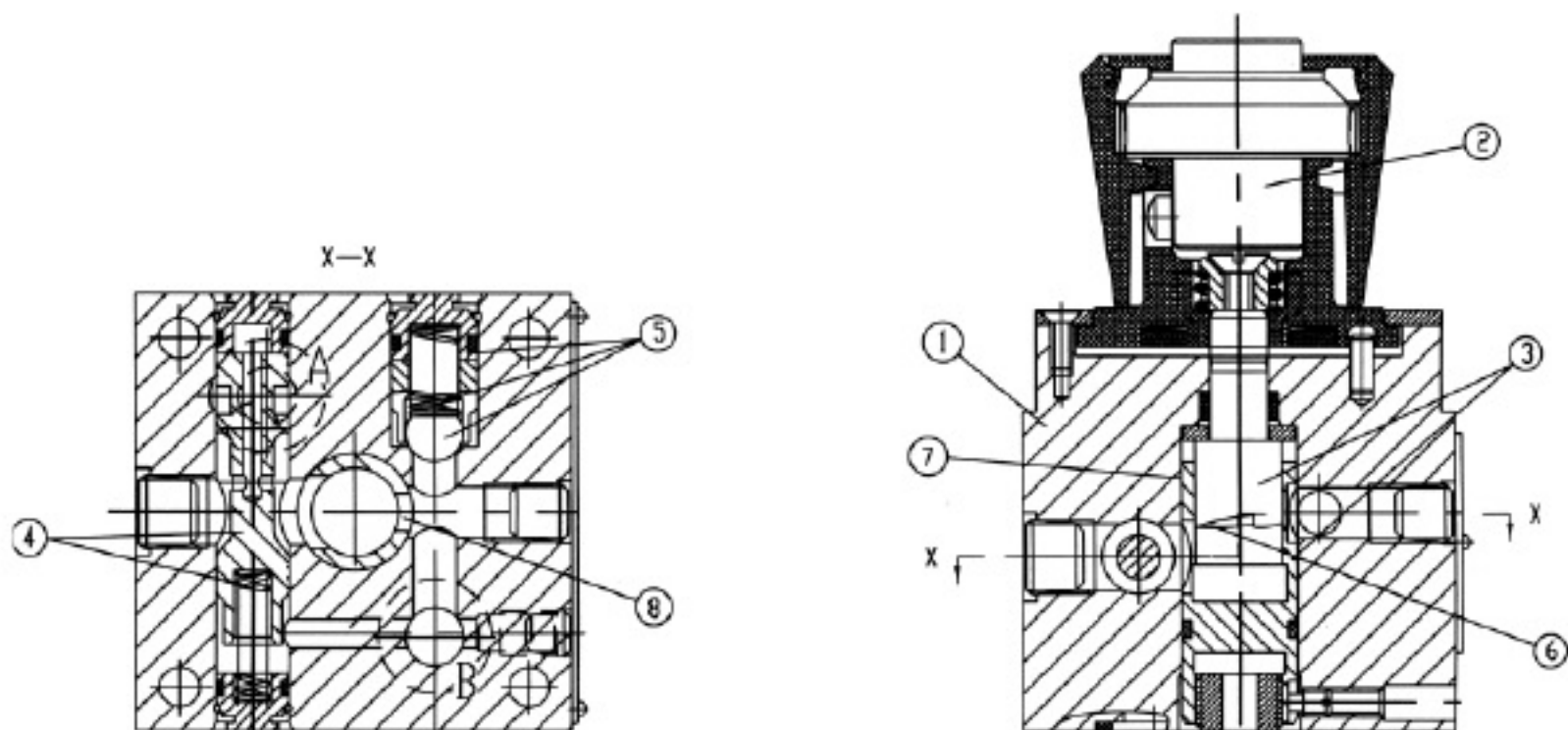

Ordering code: 2-way flow control valves

2FRM5-31 B / / / *

Series 31 (30 to 39: unchanged installation and connection dimensions) =31

Further details in clear text

Technology of Beijing Huade Hydraulic = B

No code = Mineral oil
V = Phosphate ester
(other seals on enquiry)

Progressive	Progressive	
0.2L/min=0.2Q	10L/min=10Q	flow direction A → B
0.6L/min=0.6Q	15L/min=15Q	
1.2L/min=1.2Q		
3L/min=3Q		
6L/min=6Q		

No code = without pressure compensator stroke limiter
B = with pressure compensator stroke limiter

Technical data: (for applications outside these parameters, please consult us!)

General

Hydraulic fluid	Mineral oil (for NBR seal) or Phosphate ester (for FPM seal)
Temperature range (°C)	-30 ~ + 80
Viscosity range (mm ² /s)	10 ~ 800

Rectifier sandwich plate

Flow, max (L/min)	15
Operating pressure (MPa)	up to 21
Cracking pressure (MPa)	0.1
Weight (Kg)	0.6

2-way flow control valve

Flow q_v max (L/min)	0.2	0.6	1.2	3.0	6.0	10.0	15.0
Δp with free return flow B → A, q_v -dependent (MPa)	0.05	0.05	0.06	0.09	0.18	0.36	0.67
Flow control	temperature-stable	± 5%	± 3%	± 2%			
	pressure-stable (up to $\Delta p = 21.0$ MPa)	± 2%				± 4%	
Operating pressure, max. - port A (MPa)	to 21						
Minimum pressure difference range (MPa)	0.3 to 0.5					0.6 ~ 0.8	
Degree of contamination (μ m)	25 (Q < 5L/min)			10 (Q < 0.5L/min)			
Weight (Kg)	1.6						

Ordering code: Rectifier sandwich plate

Z4S5-10 B / / *

Series 10 (10 to 19: : unchanged installation and connection dimensions) = 10

Further details in clear text

Technology of Beijing Huade Hydraulic = B

No code = Mineral oil
V = Phosphate ester

Ordering code: 2-way flow control valve

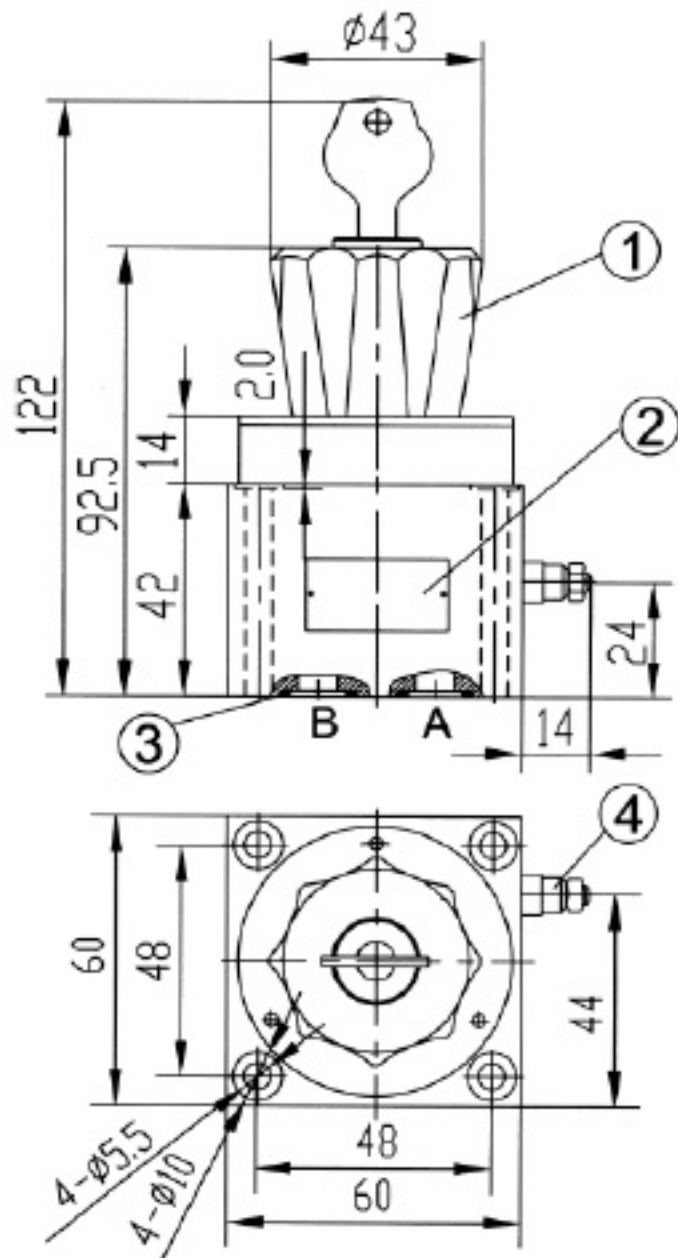

Symbols

Flow control valve simplified

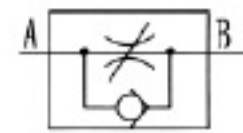

Flow control valve detailed

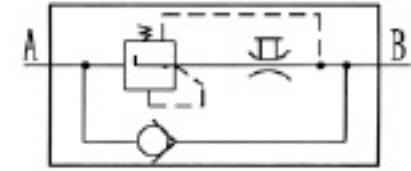

Rectifier sandwich plate

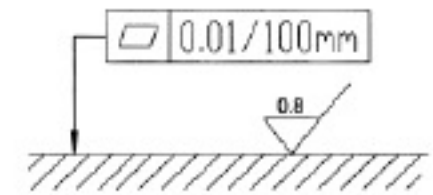
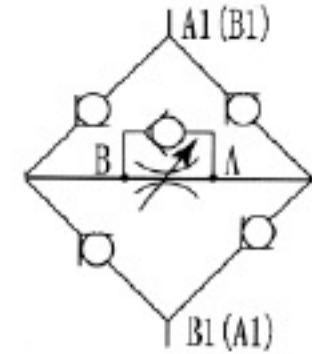

Required surface finish of the mating piece

1. Adjustment element, lockable rotary knob (may be locked in any position)

Turning range $300^\circ = 10$ scale divisions

Tightening torque $M_A = 0.5$ Nm

2. Nameplate

3. O-ring 12 x 2

4. Pressure compensator stroke limiter

Subplates for: see page 69

G 44/01 (G 1/4") G 44/02 (M14 x 1.5)

G 45/01 (G 1/2") G 45/02 (M22 x 1.5)

Characteristic curves: 2-way flow control valve (measured at $v = 41$ mm²/s and $t = 50^\circ$ C)

Flow q_v dependent on scale (flow control from A to B):

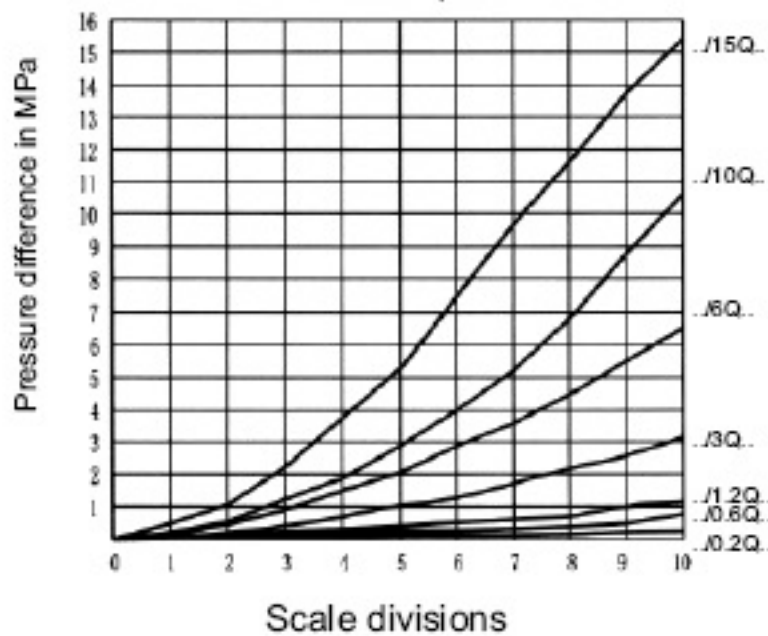

Operating curve of rectifier sandwich plate

