

BEIJING HUADE HYDRAULIC INDUSTRIAL GROUP CO.,LTD.	2-way flow control valve,Type 2FRM			RE:28383/12.2004
	Size 10 and 16	up to 31.5MPa	up to 160 L/min	Replaces; RE28383/05.2001

Features:

- Porting pattern to DIN 24 340, from A,ISO 4401 and CETOP-RP 121H
- Pressure compensator stroke limiter, optional
- Mechanical operation
- Start-up jump reduction
- Flow control in both directions using a rectifier sandwich plate

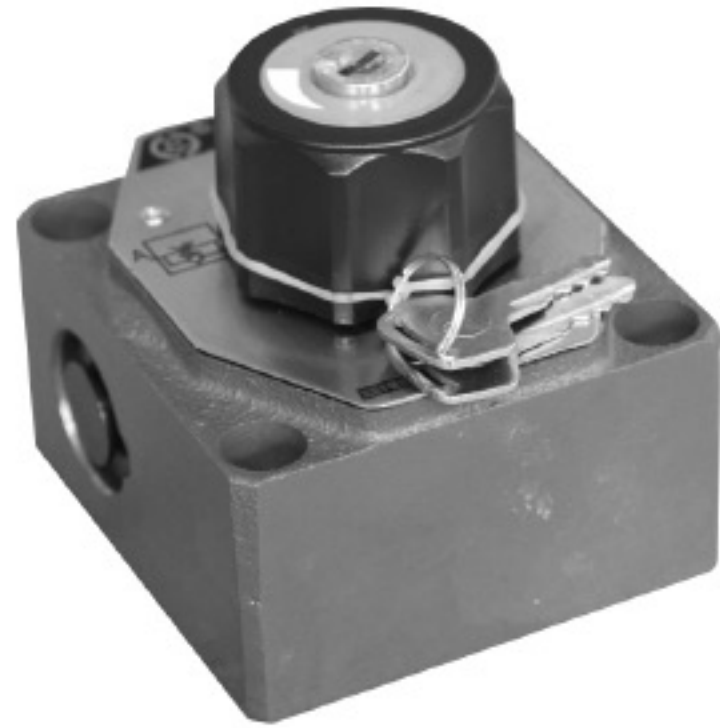

Functional, section

Flow control valves are 2-way flow control valves. They are used to maintain a flow constant independently of pressure and temperature.

The valves basically consist of the housing (1), orifice bushing(3), pressure compensator (4) with optional stroke limiter,check valve(5), adjustment element (2).

The flow from channel A to channel B is throttle at the orifice (6).In order to maintain the flow across the orifice constant, a pressure compensator is connected upstream of the orifice (6). The flow is maintained largely independent of temperature due to the orifice design.Free return flow from channel B to channel A is directed via the check valve (5). The flow is only controlled from A to B. In order to control the flows in both directions a rectifier sandwich plate type Z4S can be installed below the flow control valve.

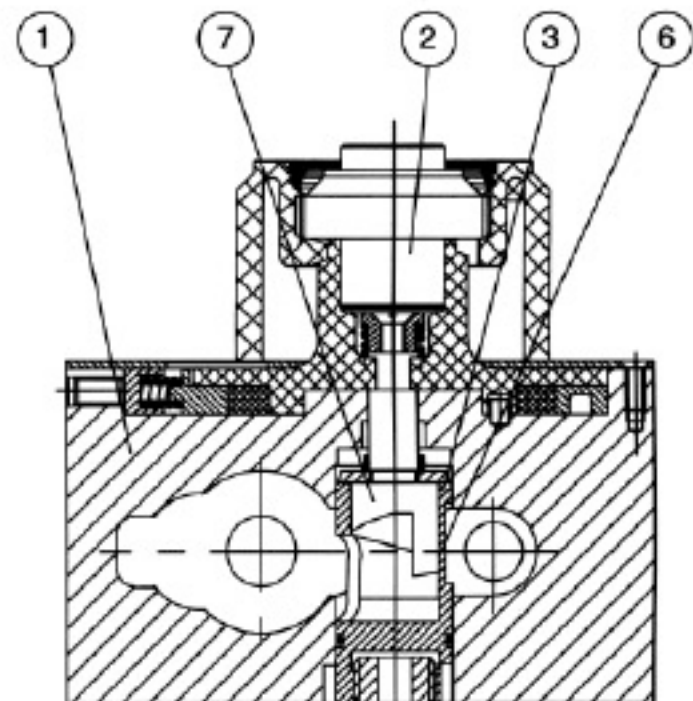
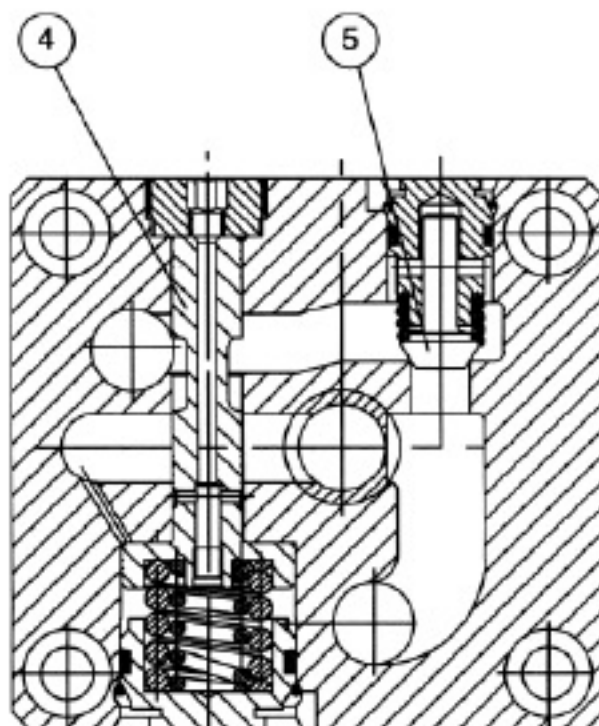

Symbols: 2-way flow control valve

Simplified



Detailed

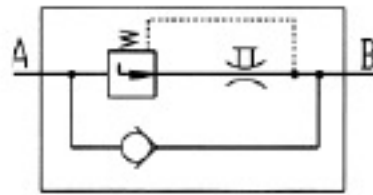

Rectifier sandwich plate

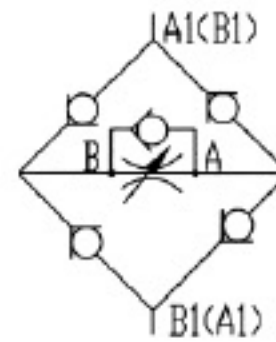

Ordering code: 2-way flow control valve

2FRM		-21	B	/			*
------	--	-----	---	---	--	--	---

Size10	=10
Size16	=16

Series 21 to 29(20 to 29: unchanged installation and connection dimensions)	= 21
-----------------------------------------------------------------------------	------

Technology of Beijing Huade Hydraulic	=B
---------------------------------------	----

Size 10, linearity	to 2L/min	=2L	Flow range A → B
	to 5L/min	=5L	
	to 10L/min	=10L	
	to 16L/min	=16L	
	to 25L/min	=25L	
	to 35L/min	=35L	
Size 16, linearity	to 50L/min	=50L	
	to 40L/min	=40L	
	to 60L/min	=60L	
	to 80L/min	=80L	
	to 100L/min	=100L	
	to 125L/min	=125L	
	to 160L/min	=160L	

Further details in clear text

No code = Mineral oil
V = Phosphate ester

No code = Without pressure compensator
stroke limiter
B = With pressure compensator stroke limiter

Ordering code: Rectifier sandwich plate

Z4S		-13	B	/		*
-----	--	-----	---	---	--	---

Size 10	= 10
Size 16	= 16

Series 10 to 19(10 to 19: unchanged installation and connection dimensions)	= 13
-----------------------------------------------------------------------------	------

Technology of Beijing Huade Hydraulic	=B
---------------------------------------	----

Further details in clear text

No code = Mineral oil
V = Phosphate ester

Technical data (For applications outside these parameters, please consult us !)

General		Rectifier sandwich plate	
		Flow, max (L/min)	Weight (Kg)
Hydraulic fluid	Mineral oil (for NBR seal) or Phosphate ester (for FPM seal)	Size 10 up to 50	Size 16 up to 160
Temperature range (°C)	-30 to +80	Operating pressure (MPa) up to 31.5	
Viscosity range (mm ² /s)	10 to 800	Cracking pressure (MPa) 0.15	
		Size 10 3.2	Size 16 9.3

Flow q_v max (L/min)	Size 10				Size 16		
		10	16	25	50	60	100
Δp with free return flow B → A q_v -dependent (MPa)	Size 10				Size 16		
	0.2	0.25	0.35	0.6	0.28	0.43	0.73
Flow control	temperature-stable (-20 to +80°C)				± 2% (q_v max)		
	pressure-stable (up to $\Delta p = 31.5$ MPa)				± 2% (q_v max)		± 5% (q_v max)
Operating pressure, max. - port A (MPa)	up to 31.5						
Minimum pressure differential range (MPa)	Size 10				Size 16		
	0.3...0.7				0.5...1.2		
Degree of contamination (µm)	25 ($q_v < 5$ L/min) 10 ($q_v < 0.5$ L/min)						
Weight (Kg)	Size 10				Size 16		
	5.6				11.3		

Characteristic curves: 2-way flow control valve (measured at $v = 41$ mm²/s and $t = 50$ °C)

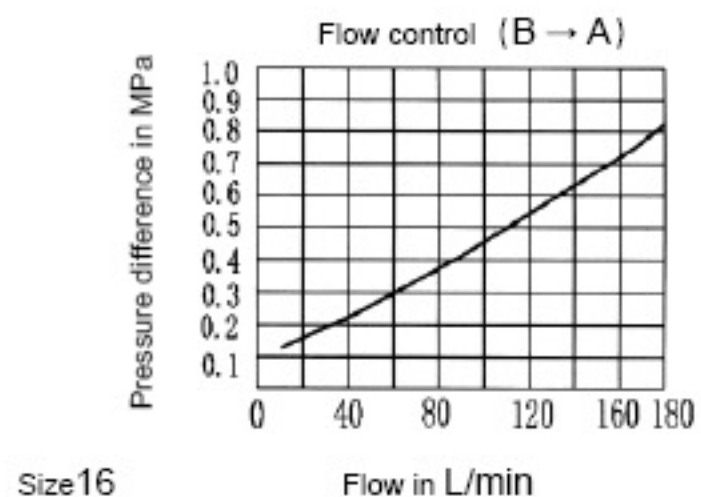
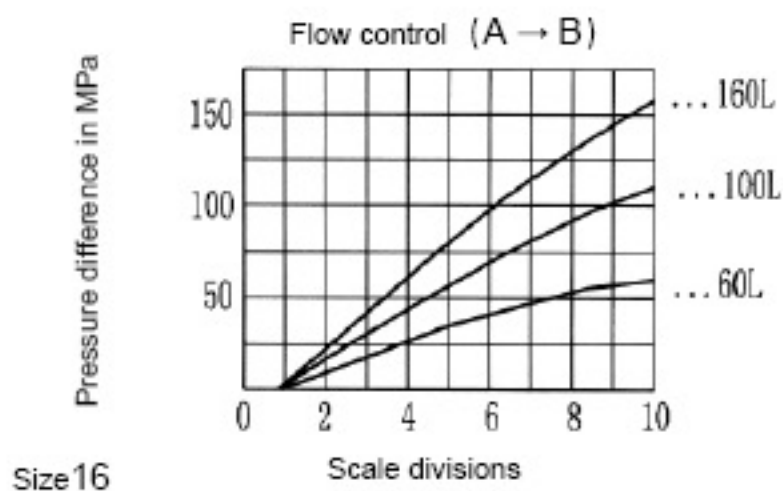
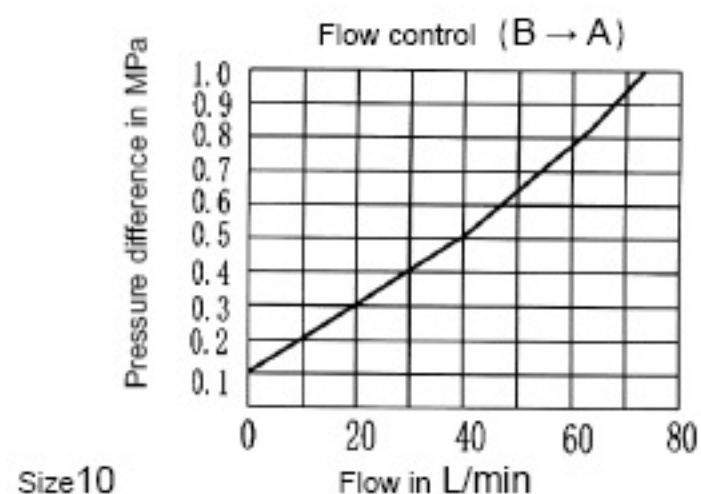
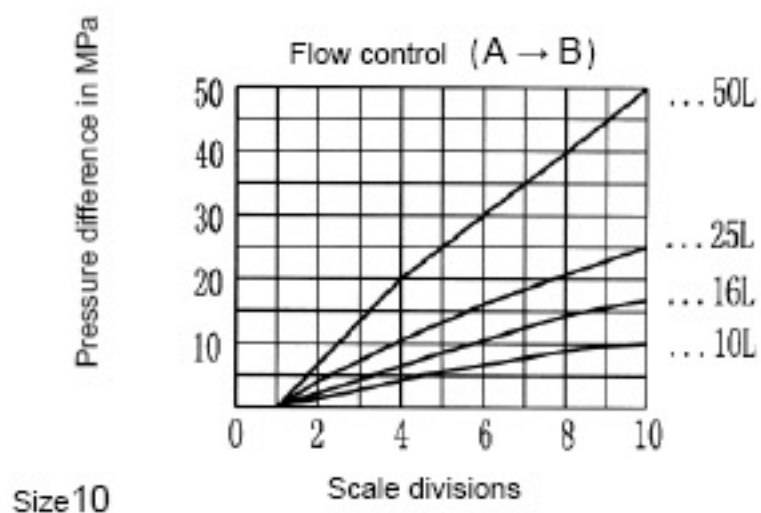

Characteristic curves: Rectifier sandwich plate (measured at $v = 41 \text{ mm}^2/\text{s}$ and $t = 50^\circ\text{C}$)

Pressure difference Δp is the same for both directions of flow

Flow q_v from A \rightarrow B (B \rightarrow A)

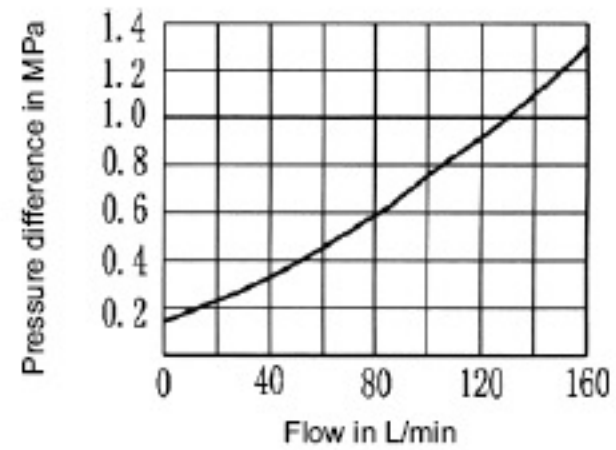
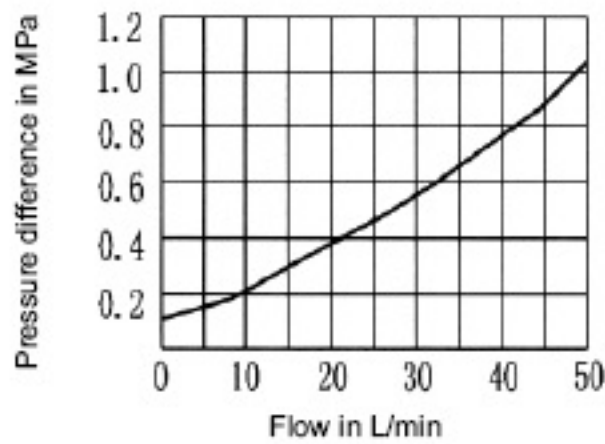

Unit dimensions: 2-way flow control valve type 2FRM

(Dimensions in mm)

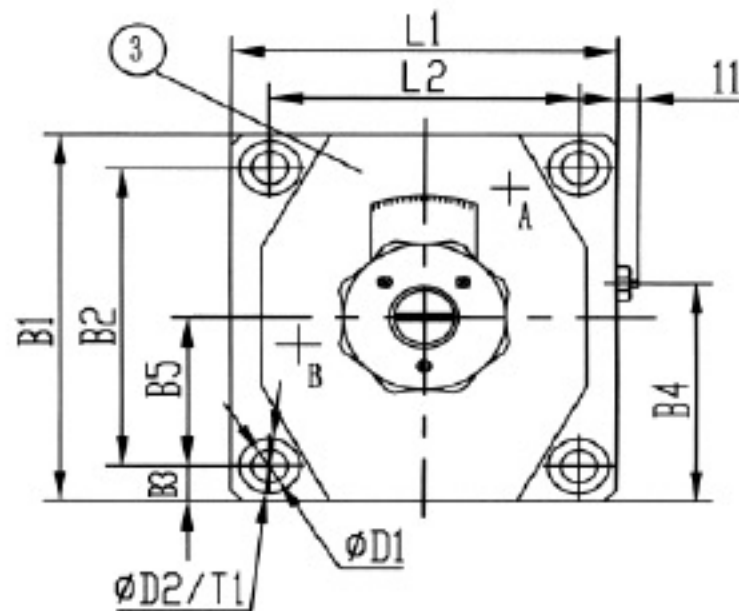
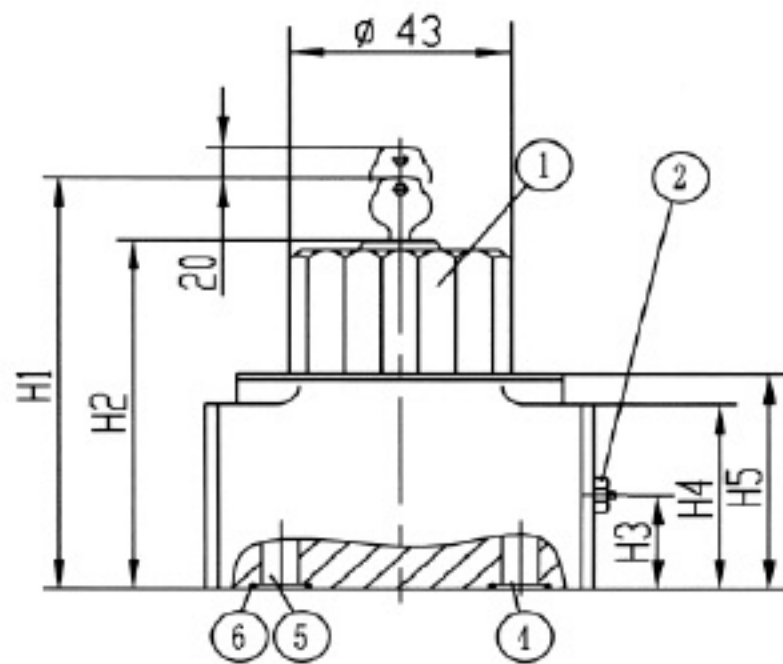

- 1. Adjustment element, lockable rotary knob (may be locked in any position) Turning range $300^\circ = 10$ scale divisions
M A = 0.7 Nm
- 2. Pressure compensator stroke limiter, optional
- 3. Nameplate
- 4. Input "A"
- 5. Output "B"

- 6. O-ring 18.66 x 3.53 (size 10)
O-ring 26 x 3 (size 16)
- Subplates for: see page 69
- Size 10: G279/01 (G1/2") G279/02 (M22X1.5)
G280/01 (G3/4") G280/02 (M27X1.5)
- Size 16: G281/01 (G1") G281/02 (M33X2)
G282/01 (G1 1/4") G282/02 (M42X1.5)

Size	B1	B2	B3	B4	B5	D1	D2	H1
10	101.5	82.5	9.5	68	35.5	9	15	125
16	123.5	101.5	11.0	81.5	41.5	11	18	147
Size	H2	H3	H4	H5	L1	L2	T1	
10	95	26	51	60	95	76	13	
16	117	34	72	82	123.5	101.5	12	

Unit dimensions: Rectifier sandwich plate

(Dimensions in mm)

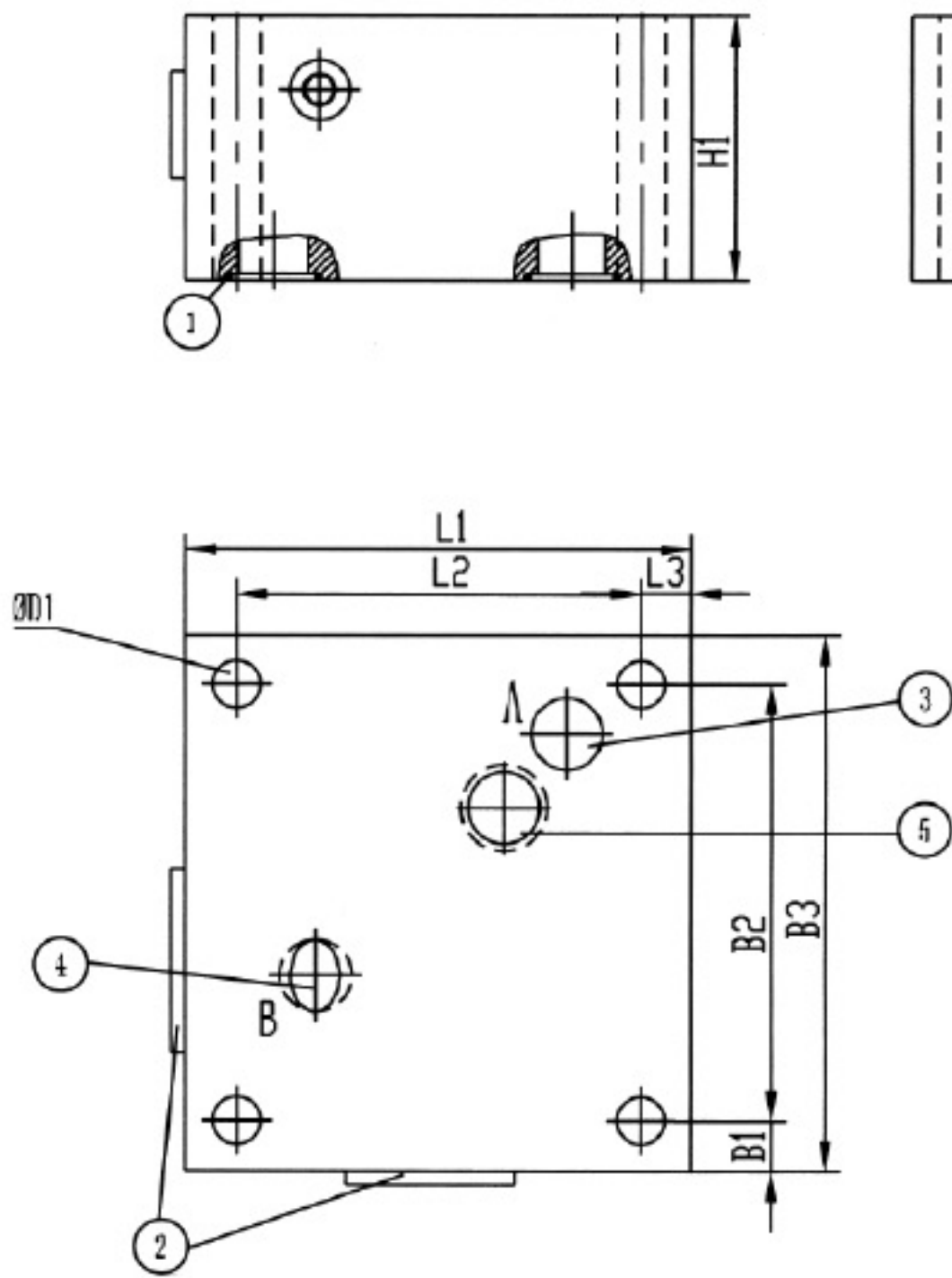

- 1. O-ring 18.66 x 3.53 (size 10)
O-ring 26 x 3 (size 16)
- 2 Nameplate
- 3. Input "A"
- 4. Output "B"
- 5 only for size 16, the orifice is sealed by o-ring, thus, fitting element doesn't drilling it.

Valve fixing screws for:	Size10	4-M8x50-10.9 (GB/T70.1-2000)						
	Size16	4-M8x80-10.9 (GB/T70.1-2000)						
Valve fixing screws for inserting a rectifier sandwich plate between the flow control valve and subplate have to be ordered separately.		M8x100-10.9 (GB/T70.1-2000)						
	Size10	4 fixing screws						
	Size16	4 fixing screws M10x160-10.9 (GB/T70.1-2000)						
Size	B1	B2	B3	φ D1	H1	L1	L2	L3
10	9.5	82.5	101.5	9	50	95	76	9.5
16	11	101.5	123.5	11	85	123.5	101.5	11

Notice

1. The fluid must be filtered. Minimum filter fineness is 20 μm .
2. The tank must be sealing up and an air filter must be installed on air entrance.
3. Products without subplate when leaving factory, if need them, please ordering specially.
4. Valve fixing screws must be high intensity level (class 10.9). Please select and use them according to the parameter listed in the sample book.
5. Roughness of surface linked with the valve is required to $\frac{0.8}{\nabla}$.
6. Surface finish of mating piece is required to 0.01/100mm.