

BEIJING HUADE HYDRAULIC INDUSTRIAL GROUP CO.,LTD.	<b>check valve Type Rvp</b>			RE 20400/12.2004
	Size 6 to 40	up to 31.5 MPa	up to 600L/min	Replaces: RE 20400/05.2001

**Features:**

- Subplate connection
- Leakage-free closure in one direction



**Description,section,symbol**

The check valve type RVP has the task of, preferably closing a flow leakfree in one direction and to permit free flow in the opposite direction. It basically comprises of the housing (1), poppet (2) compression spring (3),and spring seat(4).

The stroke of the poppet (2), which is guided on its outside diameter, is limited by a mechanical stop. The built-in compression spring (3) supports the closing movement. Furthermore the compression spring (3) holds the poppet (2) in the closed position even when there is no flow through the valve.

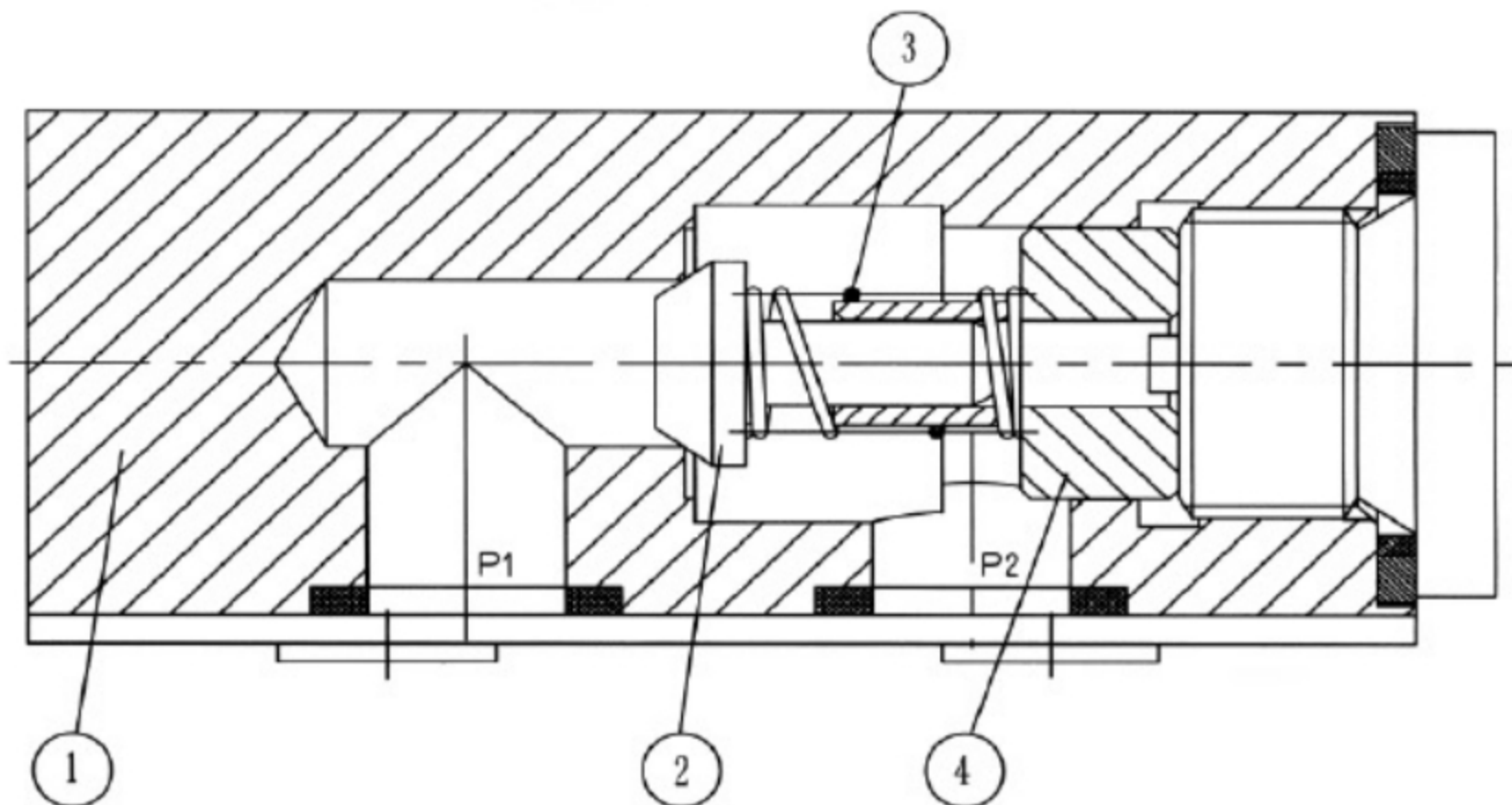
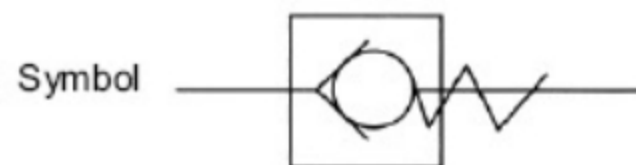

1. Housing 2.Poppet 3. Spring 4. Spring seat

## Ordering details

	RV	P		10	B		*
--	----	---	--	----	---	--	---

Check valve

Subplate mounting =P

Size	
6	=6
8	=8
10	=10
12	=12
16	=16
20	=20
25	=25
30	=30
40	=40

Futher details in clear text

No code = Mineral oils  
V = phosphate estery

B = The technology of Beijing Huade Hydraulic

10= series 10 to 19  
(10 to 19: unchanged installation and connection dimensions)

## Technical data

Size		6	8	10	12	16	20	25	30	40	
Operating pressure, max.	(MPa)	31.5									
Opening pressure	(MPa)	0.05									
Pressure fluid		mineral oils or phosphate ester									
Pressure fluid temperature range	(°C)	- 30 to + 80									
Viscosity range	(mm <sup>2</sup> /s)	2.8 to 500									
Fixing position		optional									

## Characteristic curves (measured at $v = 41 \text{ mm}^2/\text{s}$ and temperature $t = 50^\circ\text{C}$ )

Direction of flow: P1 to P2      The relationship between pressure differential  $\Delta p$  and flow Q

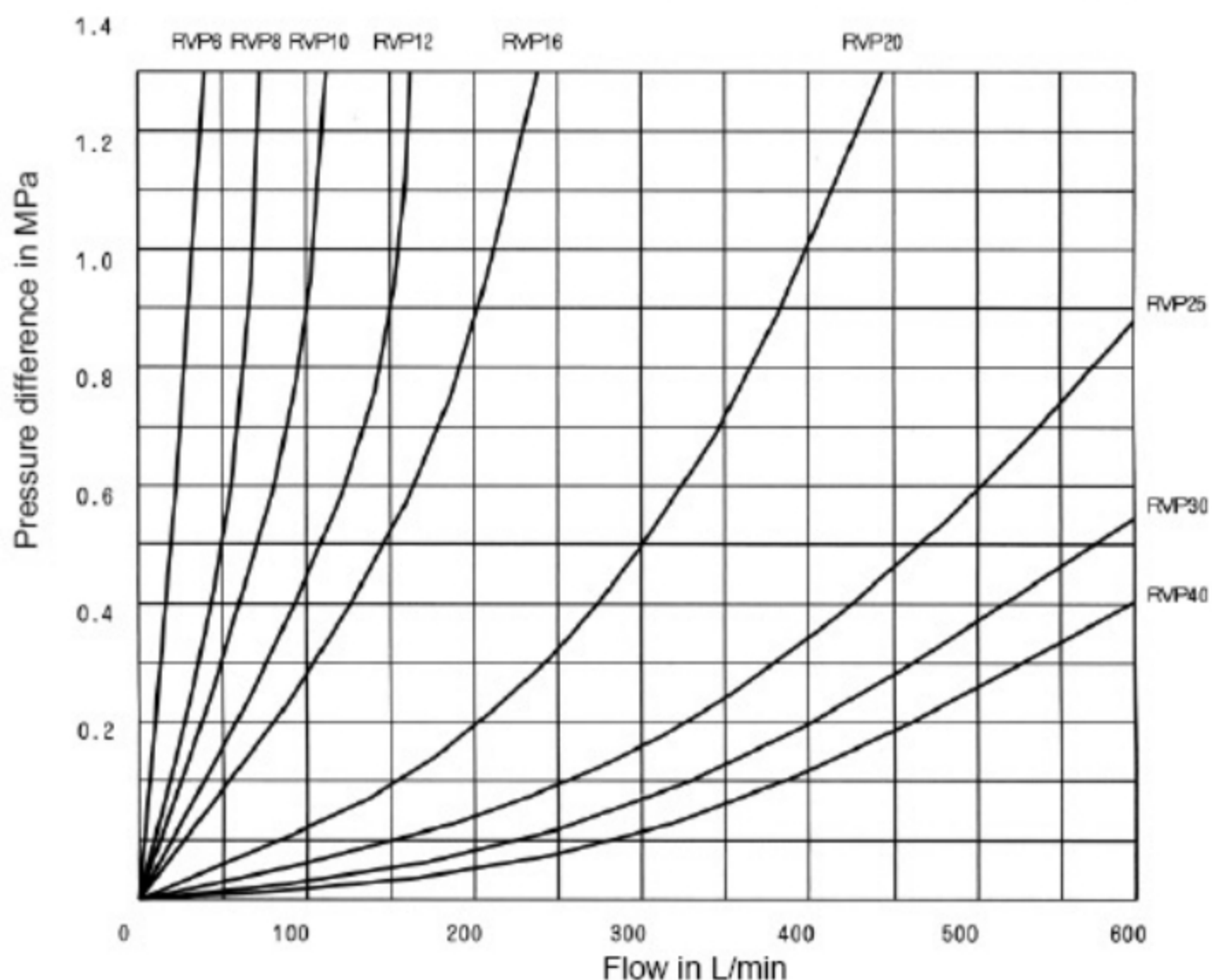

**Unit dimensions**

**(Dimensions in mm)**

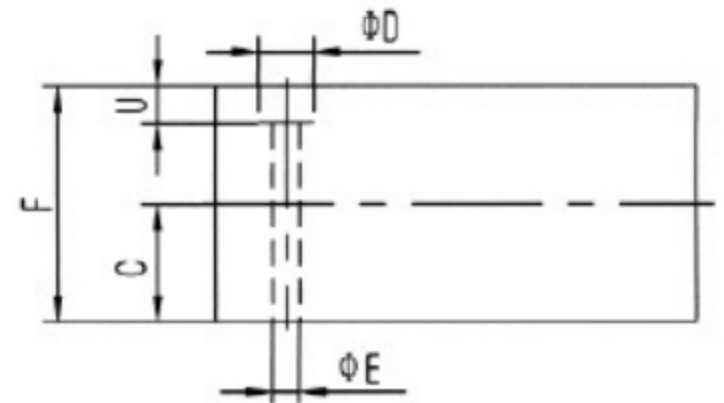
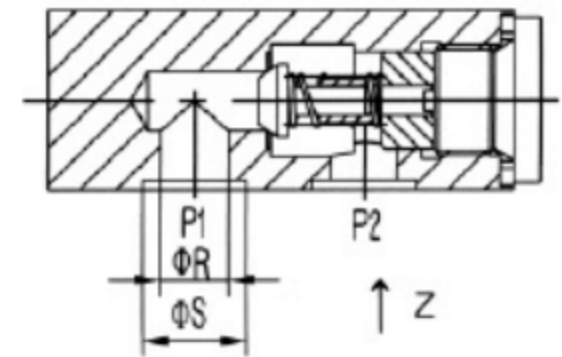
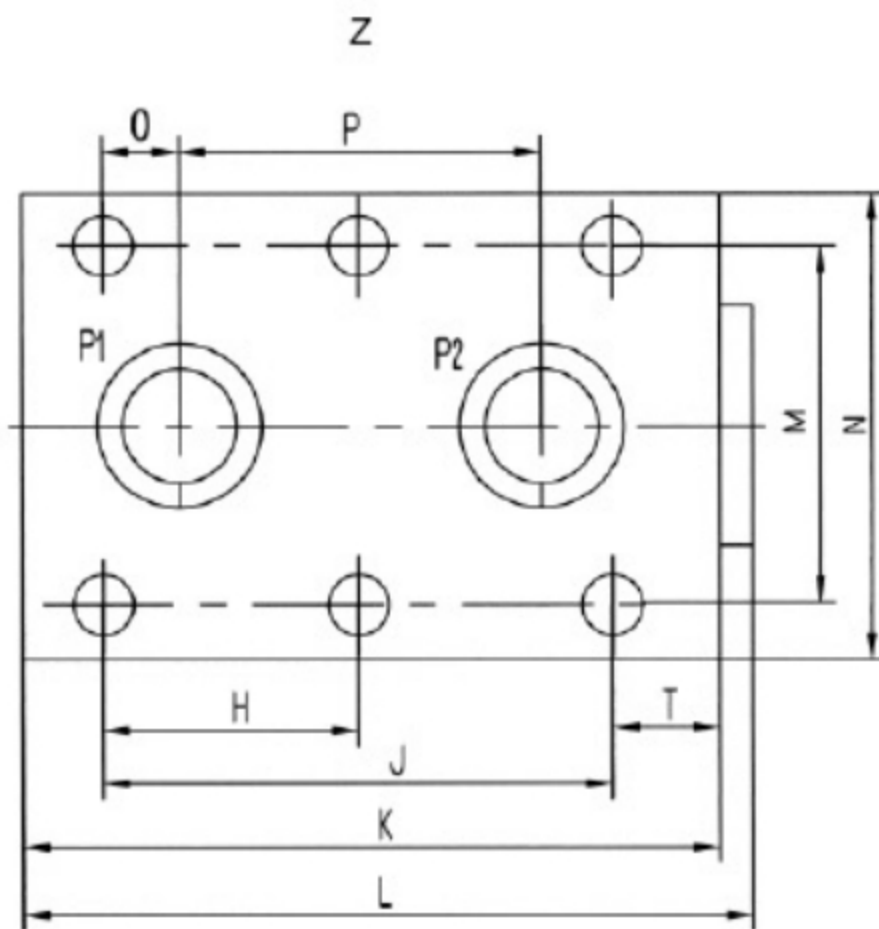

Size	C	φD	φE	F	H	J	K	L	
RVP-6	11.5	11	6.6	23	-	19	41.5	46	
RVP-8	13	11	6.6	24	-	35	63.5	67	
RVP-10	13.5	11	6.6	27	-	33.5	70	74	
RVP-12	16	11	6.6	32	-	38	80	84	
RVP-16	22.5	14	9	45	38	76	104	109	
RVP-20	26	14	9	50	47.5	95	127	132	
RVP-25	29	18	11	58	60	120	165	170	
RVP-30	37.5	20	14	75	71.5	143	186	192	
RVP-40	50	20	14	100	67	133.5	192	198	
Size	M	N	O	P	Φ R	Φ S	T	U	Weight(Kg)
RVP-6	28.5	41.5	1.6	16	6	12.2	16.1	8	0.26
RVP-8	33.5	46	4.5	25.5	8	13.7	14.3	10	0.50
RVP-10	38	51	4	25.5	10	15.7	18.5	7	0.80
RVP-12	44.5	57.5	4	30	13	21.8	21	7	1.10
RVP-16	54	70	11.4	54	17	24.5	16	12	2.25
RVP-20	60	76.5	19	57	22	31.5	16	12	3.90
RVP-25	76	100	20.6	79.5	28.5	39.2	30	13	6.70
RVP-30	92	115	23.8	95	31	41	28	13	11.0
RVP-40	111	140	25.5	89	45	54	42.5	18	17.0

## Notice

1. The fluid must be filtered. Minimum filter fineness is 20  $\mu\text{m}$ .
2. The tank must be sealing up and an air filter must be installed on air entrance.
3. Products without subplate when leaving factory, if need them, please ordering specially.
4. Valve fixing screws must be high intensity level (class 10.9). Please select and use them according to the parameter listed in the sample book.
5. Roughness of surface linked with the valve is required to  $\frac{0.8}{\sqrt{\text{ }}$ .
6. Surface finish of mating piece is required to 0.01/100mm.