

Catalogue

Distribution product

Wenzhou Xucky Electric Co.,Ltd

www.xucky.com



**Air circuit breaker
ACB**

**Motor protective Circuit Breaker
MPCB**

**Miniature circuit breaker
MCB**

**Moulded Case circuit breaker
MCCB**

**Surge Protector Device
SPD**

**Residual current circuit breaker
RCCB**



M1-63M/3P



M1-63M/4P



M1-125L/3P



M1-250L/3P

M1 Series Moulded Case Circuit Breaker

1. Application

M1 series moulded case circuit breaker is one of products developed and manufactured by adopting international advanced technology. It is supplied with rated insulating voltage 500 and 800V and used for the circuit of AC 50/60Hz, rated operating voltage AC 400V (or below), rated operating current up to 1600A for infrequently changing over and starting of the motors. The products conform to IEC60947-2 standard.

2. Main Technical Specification

Table 1

Type	Rated current(A)	Pole	Rated insulating voltage (V)	Rated operating voltage (V)	Arcing-over distance (mm)	Ultimate short circuit breaking capacity (kA)	Service short circuit breaking capacity (kA)	Operation performance		Utilization category
								Load	Unload	
M1-63L	(6),10,16	3,4	500V	400V	0	25	18	1500	8500	A
M1-63M	20,25,32				0	50	35			
M1-125L	(10),16,20,25				0(≤50)	35	22			
M1-125M	32,40,50,63				0(≤50)	50	35			
M1-250L	100,125,160				≤50	35	22			
M1-250M	180,200,225				≤50	50	35			
M1-400L	225,250,315		800V	400V	≤50	50	35	1000	7000	
M1-400M	350,400				≤100	65	42			
M1-630L	400,500,600				≤100	50	35			
M1-630M					≤100	65	42			
M1-800M					≤100	75	50			
M1-1250M	1000,1250				≤100	100	65			
M1-1600M	1600	≤100	150	80						

Note: 6A without thermal protection

The N-pole of four-poles breaker is sited at the right side of the product has four types:

Type A: Without current trip-release on N pole which making all the time, not closing and opening with the other three poles.

Type B: Without current trip-release on N pole which closing and opening with the other poles.

Type C: With current trip-release which closing and opening with the other three poles.

Type D: With current trip release which making all the time not closing and opening with the other three poles.

3. Protection Characteristic

The thermodynamic release of a circuit breaker provides the feature of inverse time-delay, while the magnetic release is the instantaneous operation as shown on table 2(distribution circuit breaker) and table 3(motor protection circuit breaker).



M1-400L/3P



M1-630L/3P



Back panel connection



Plug-in connection



Electromagnetic operation device



Motor-driven operation device

Table 2

Rated current of release (A)	Thermodynamic release (ambient temperature $\begin{matrix} \text{land } +40^{\circ}\text{C} \\ \text{marine } +45^{\circ}\text{C} \end{matrix}$)		Operating current of magnetic release (A)
	1.05In(cold state) Inoperative time(h)	1.30In(heat state) Operative time(h)	
$10 \leq I_n \leq 63$	≥ 1	< 1	$10I_n \pm 20\%$
$63 < I_n \leq 100$	≥ 2	< 2	
$100 < I_n \leq 800$	≥ 2	< 2	$5I_n \pm 20\%$ $10I_n \pm 20\%$

Table 3

Rated current of release (A)	Thermodynamic release (ambient temperature $\begin{matrix} \text{land } +40^{\circ}\text{C} \\ \text{marine } +45^{\circ}\text{C} \end{matrix}$)				Operating current of magnetic release (A)
	1.0In(cold state) non-trip time(h)	1.20In(heat state) trip time (h)	1.50In(heat state) trip time (m)	7.2In(cold state) trip time(s)	
$10 \leq I_n \leq 250$	≥ 2	< 2	≤ 4	$4 < t \leq 10$	$12I_n \pm 20\%$
$250 < I_n \leq 630$			≤ 8	$6 < t \leq 20$	

4. Accessories of Circuit Breaker

4.1 The external accessories of the breaker

- Electromagnetic operation device and Motor-driven operation device

1) Wiring diagram of type CDM electromagnetic operation device(fitting AM1-63,100,250) see the following drawing (wiring diagram of the external accessories of the breaker in the dotted frame)

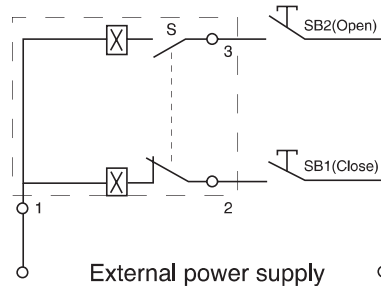

Code description: SB1, SB2 stand for push button.(provided by users themselves)

Number "1"、"2"、"3" stand for number of wiring terminals.

Voltage rating: AC50/60Hz 230V 400V, DC 220V

2) Wiring diagram of type CD Electromagnetic operation device and motor-driven operation device (fitting AM1-400、630、800) see belows (wiring diagram of the external accessories of the breaker in the dotted frame)

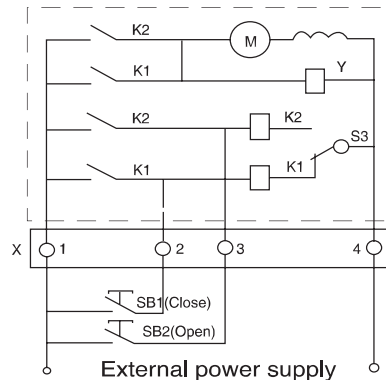

Code description: SB1, SB2 stand for push button. (provided by users themselves)

"X" stands for line connection terminals

Voltage rating: AC50/60Hz 230V 400V, DC220V

● **Rotary handle operation device**

The mechanism is used with moulded case circuit breaker to operate the draw-out panel. Power distribution panel and supply box outside the panel by turning the handle ,and to ensure the door of panel would not be opened when the breaker being on.

The hand-drive mechanism can be equipped with two types of operation, one is “A” model square handle , the other is “B” model round handle.

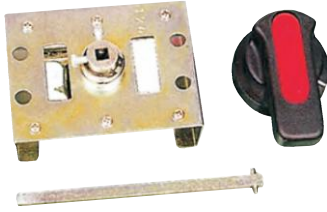

Rotary handle operation device

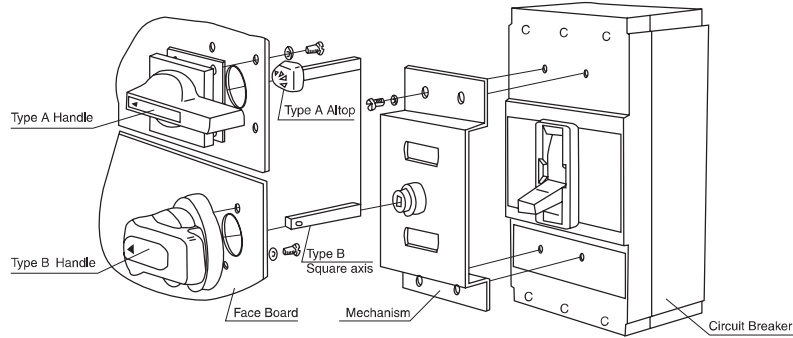

4.2 Release pattern and accessories code

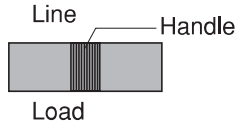

UVR: Under-voltage release; SHT: Shunt release;
AL: Alarm contact AX: Auxiliary contact;

Release pattern and accessories code	Name / Type	AM1-63, 100, 250	AM1-400	AM1-630	AM1-800
200, 300	Without accessories	200: magnetic release (only short circuit protection) 300: thermal magnetic release(both overload and short circuit protection)			
208, 308	Alarm contact	AL	AL	AL	AL
210, 310	Shunt release	SHT	SHT	SHT	SHT
220, 320	Auxiliary contact	AX	AX	AX	AX
230, 330	Under-voltage release	UVR	UVR	UVR	UVR
240, 340	Shunt release Auxiliary contact	SHT AX	SHT AX	SHT AX	AX SHT
250, 350	Shunt release Under-voltage release	SHT UVR	SHT UVR	SHT UVR	UVR SHT
260, 360	Two group of auxiliary contact	AX AX	AX AX	AX AX	AX AX
270,370	Under-voltage release Auxiliary contact	AX UVR	AX UVR	AX UVR	UVR AX
218, 318	Shunt release Alarm contact	AL SHT	SHT AL	AL SHT	AL SHT
228, 328	Alarm contact Auxiliary contact	AL AX	AL AX	AL AX	AL AX
238, 338	Under-voltage release Alarm contact	AL UVR	AL UVR	AL UVR	AL UVR
248, 348	Shunt release, Alarm contact, Auxiliary contact	AL AX SHT	SHT AL AX	AL AX SHT	AL AX SHT
268, 368	Two group of auxiliary contact, Alarm contact	AL AX AX	AL AX AX	AL AX AX	AL AX AX
278, 378	Shunt release, Alarm contact, Under-voltage release	SHT AL UVR	AL UVR SHT	AL UVR SHT	SHT AL UVR

According to user's demands, accessories could lead to direct wire outcoming or line wiring terminals could be added (please mark out in case of placing order).

● Under-voltage release

Wiring diagram of the under-voltage release connected externally (the internal accessories in the dotted frame)

Ue: AC230V, 400V



Under-voltage release

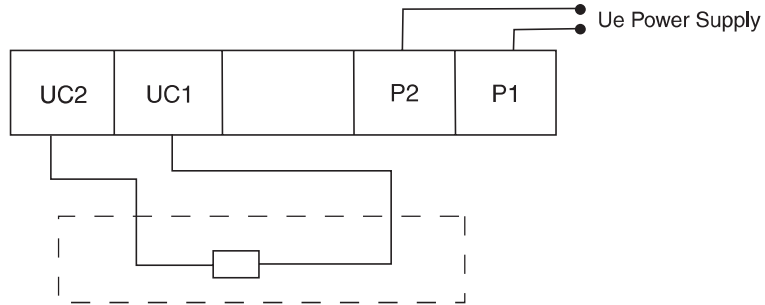

When the operation voltage is 35%~70% of the rated voltage, the under-voltage release should make the breaker trip correctly.

When the operation voltage is 85%~110% of the rated voltage, the under-voltage release should make the breaker close.

In case of the operation voltage less than 35% of the rated voltage, the under-voltage should prevent the breaker from closing.

Note: Only the under-voltage release should be energized in advance, the breaker could be recramped and turned-on, otherwise the breaker will be damaged.

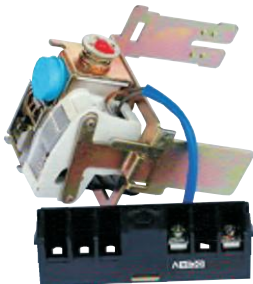

Shunt release

● Shunt release

Wiring diagram of the shunt release (the internal accessories in the dotted frame)

"K" is the slow motion switch normal-close contact connect the coil in series in the shunt release.

It turns-on or turns-off automatically as soon as the breaker on or off.

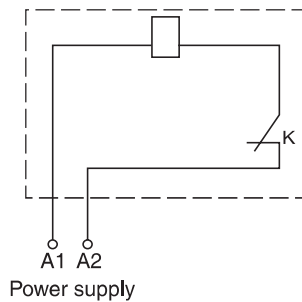

Voltage rating: AC230V 400V, DC 110V 220V

The shunt release should make the breaker trip reliably when the operation voltage is 70%~110% of the rated control voltage.

● Alarm contact



Alarm contact

The position of the breaker in "off" or "on"	
The position of the breaker in "free trip" (alarm)	B11 and B12 switch from "close" to "open", status of B11 and B14 switch from "open" to "close"

● Auxiliary Contact



Auxiliary Contact

When the breaker is in "off"		For the breaker with frame current 400A and above
		For the breaker with frame current 250A and below
When the breaker is in "on"	When the breaker is in "off", the contacts switch from "close" to "open". When the breaker is in "off", the contacts switch from "open" to "close"	

5. Outline and Installation Dimensions (mm)

Type	Outline Dimensions(mm)																												Installation Dimensions							
	Front panel connection														Back panel connection						Plug-in connection															
	W	W1	L	L1	L2	H	H1	H2	H3	H4	C	D	E	F	G	W2	W3	L4	H5	H6	ØD	ØD1	L5	L6	H7	H8	H9	H10	J	K	Ød1	M	A	B	Ød	
AM1-63L	76	50	135	170	117	74	92	20	7	4	85	28.5	48	22	14	100	75	117	44	66	8	8							60.7				25	117	3.5	
AM1-63M	76	50	135	170	117	82	98.5	28	7	4	85	28.5	48	22	14	100	75	117	44	66	8	8							62				25	117	3.5	
AM1-100L	92	60	150	185	132	68	86	24	7	4	88	35.5	50	22	17.5	122	90	129	68	108	26	16	92	168	50	62	74	17.5	56	60	6.5	M8	30	129	4.5	
AM1-100M	92	60	150	185	132	86	104	24	7	4	88	35.5	50	22	17.5	122	90	129	68	108	26	16	92	168	50	62	74	17.5	56	60	6.5	M8	30	129	4.5	
AM1-250L	107	70	165	215	144	86	110	24	5	4	102	31.5	50	22	17	142	105	126	66	110	20	20	94	183	50	69.5	84.5	17.5	54	70	6.5	M8	35	126	5	
AM1-250M	107	70	165	215	144	103	127	24	5	4	102	31.5	50	22	17	142	105	126	66	110	20	20	94	183	50	69.5	84.5	17.5	54	70	6.5	M8	35	126	5	
AM1-400L	182	116	270	370	234	110	160	43	8	6	134	70	89	65	ø29	198	144	200	65	125	36	36	169	299	60	92	110	21	123	100	8.5	M12	58	200	7	
AM1-400M	182	116	270	370	234	110	160	43	8	6	134	70	89	65	ø29	198	144	200	65	125	36	36	169	299	60	92	110	21	123	100	8.5	M12	58	200	7	
AM1-630L	182	116	270	370	234	110	160	43	8	6	134	70	89	65	ø29	240	174	200	65	125	36	36	169	299	60	92	110	21	123	100	8.5	M12	58	200	7	
AM1-630M	182	116	270	370	234	110	160	43	8	6	134	70	89	65	ø29	240	174	200	65	125	36	36	169	299	60	92	110	21	123	100	8.5	M12	58	200	7	
AM1-800M	210	140	280	380	243	106	145	33	30	128									128														70	243	7.2	
AM1-1250M	210	140	393			200																														
AM1-1600M	210	140	393			200																														

Front panel connection

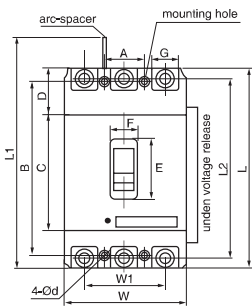

Back panel connection

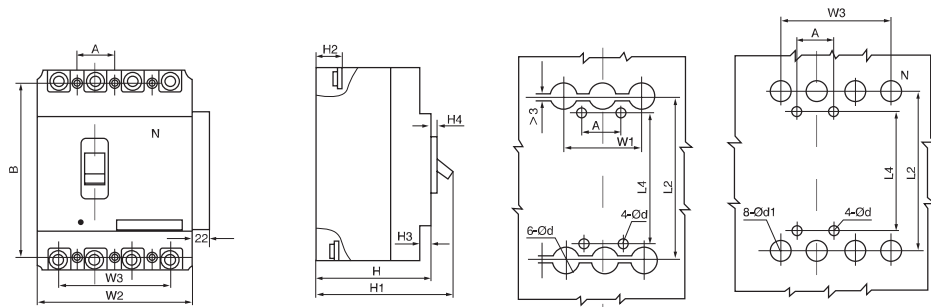

Back panel connection

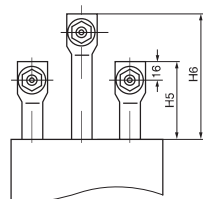
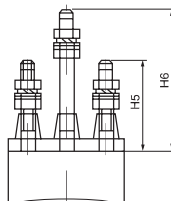

Plug-in connection

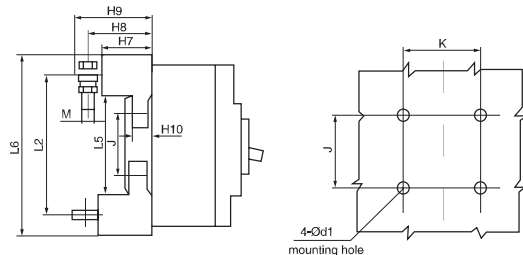

M1E Series Moulded Case Circuit Breaker



M1E-250/3300



M1E-250/4300



M1E-800/3300



M1E-800/4300

1. Application

M1E series intelligent moulded case circuit breaker is developed and manufactured by adopting international advanced technology. It is supplied with rated insulating voltage 800V and used for circuit of AC 50/60Hz, rated operating voltage 400V, rated operating current up to 800A of the circuit breaker infrequent changing over and starting of the motors. The circuit breaker has protection function of overload long delay inverse time, short circuit short delay time limit, short circuit instantaneous and under voltage, which can protect the line and power supply equipment from damage.

The circuit breaker can be mounted vertically(i.e. vertical) or horizontally. The Circuit breaker can not be poured into the line, that is, only 1,3,5 connect power cord;2,4,6 connect load line.

The circuit breaker conforms to following standards:

- IEC60947-1 GBIT14018.1 low-voltage switchgear and control equipment Part I: General
- IEC60947-2 GB14048.2 low-voltage switchgear and control equipment, the second part of circuit breaker and annex with electronic over-current protection circuit breaker additional requirement;
- IEC60947-4 GB14048.4 low-voltage switchgear and control equipment contactors and motor starts;
- IEC60947-5.1 GB14048.5 low-voltage switchgear and control equipment electromechanical control circuit electrical appliances.
- GB22710 electronic controller for low voltage circuit breaker.

2. Main Performance Characteristics

M1E intelligent moulded case circuit breaker is belongs to B category with three grades protection. In the short-circuit conditions, M1E has a fully selective cooperation with some other short-circuit protection devices in the same circuit.

With five tripping feature options. The users can adjust & set the tripping current according to the load current requirements

The energy of electronic release is provided by the circuit breaker itself. The current signal and the control source are from the toroidal current transformer which is installed in the circuit breaker.

With warning indication: When the load current exceeds the preset current, the LED on the circuit breaker cover indicates yellow;

With overload indication: When the load current exceeds the set current, the LED on the circuit breaker cover indicates red;

With a dedicated fire overload no-trip only alarm function. When the load current overload operation, the circuit breaker does not trip, outputs a passive contact, drive the corresponding alarm device;

Compliance with IEC60947 Appendix F of the electromagnetic compatibility requirements;
Dimensions are same to the same frame M1 molded case circuit breaker, installation is interchangeable.

3. Type and Meaning

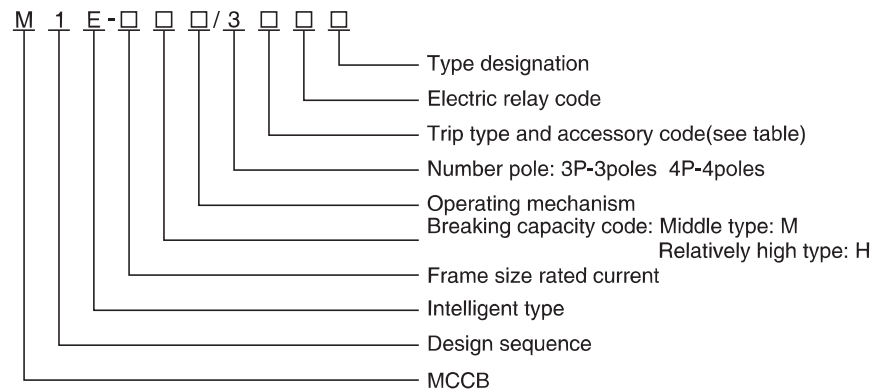

Note:
 1.Distribution without code, protection motor code: 2;
 2.Electronic accessories are: 1 communication module, 11 communication with shunt, 111 communication with passive auxiliary contacts, IV overload alarm does not trip module, no electronic components code;
 3.According to the number of poles of the product is divided into three poles and four poles, 4 poles N type: N pole over load current protection, time parameter 100% automatic tracking phase line setting value, and N pole and other three poles ON-OFF Together(N pole turn off after close);
 4.Directly operation without code, motor operation: P indicate, turn handle: Z indicate.

4. Main Technical Performance of Circuit Breaker

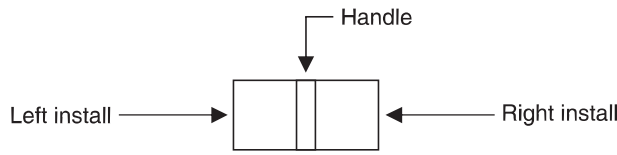

- ▲ Under-voltage release
- Shunt release
- Alarm contact
- Two group of auxiliary contact
- Leading wire

Table 1

Accessories code	Type	Pole Name	M1E-125		M1E-250		M1E-400		M1E-800	
			3	4	3	4	3	4	3	4
308	Alarm contact		← ●	← ●	← ●	← ●	← ●	← ●	← ●	← ●
310	Shunt release		← ■	← ■	← ■	← ■	← ■	← ■	← ■	← ■
320	Auxiliary contact		← ○	← ○	← ○	← ○	← ○	← ○	← ○	← ○
330	Under-voltage release		← ▲	← ▲	← ▲	← ▲	← ▲	← ▲	← ▲	← ▲
340	Shunt release Auxiliary contact			← ■ ○ →	← ■ ○ →	← ■ ○ →	← ■ ○ →	← ■ ○ →	← ■ ○ →	← ■ ○ →
350	Shunt release Under-voltage release		—	—	—	—	—	← ■ ▲ →	← ■ ▲ →	← ■ ▲ →
360	Two group of auxiliary contact		← ○ ○ →	← ○ ○ →	← ○ ○ →	← ○ ○ →	← ○ ○ →	← ○ ○ →	← ○ ○ →	← ○ ○ →
370	Auxiliary contact Under-voltage release		← ▲ ○ →	← ▲ ○ →	← ▲ ○ →	← ▲ ○ →	← ▲ ○ →	← ▲ ○ →	← ▲ ○ →	← ▲ ○ →
318	Shunt release Alarm contact		—	—	—	—	← ● ■ →	← ● ■ →	← ● ■ →	← ● ■ →
328	Auxiliary contact Alarm contact		← ● ○ →	← ● ○ →	← ● ○ →	← ● ○ →	← ● ○ →	← ● ○ →	← ● ○ →	← ● ○ →
338	Under-voltage release Alarm contact		—	—	—	—	← ▲ ● →	← ▲ ● →	← ▲ ● →	← ▲ ● →
348	Shunt release Auxiliary contact Alarm contact		—	—	—	—	← ● ■ ○ →	← ● ■ ○ →	← ● ■ ○ →	← ● ■ ○ →
368	Two group of auxiliary contact Alarm contact		← ○ ○ ○ →	← ○ ○ ○ →	← ○ ○ ○ →	← ○ ○ ○ →	← ○ ○ ○ →	← ○ ○ ○ →	← ○ ○ ○ →	← ○ ○ ○ →
378	Auxiliary contact Under-voltage release Alarm contact		—	—	—	—	← ▲ ● ○ →	← ▲ ● ○ →	← ▲ ● ○ →	← ▲ ● ○ →

Note:
 a. Release and internal accessories code first number 3 with three section protection electronic release. After the two digit indicate the internal attachment code. No internal accessory attachments with 00.
 b. 348 specifications of AM1E-800 auxiliary contact for a pair of contacts (i.e., 1 NO and 1 NC). 368 specifications auxiliary contact three pairs of contacts(3 NO and 3 NC).
 c. 4P product with N form is only separable type.

5. Capacity Loss and Coefficient Ratio

Capacity loss

Table 3

Type	Charging current	Total power loss for three phases	
		Front-panel board or back panel board connection	plug-in connection
M1E-125	125	35	
M1E-250	250	62	40
M1E-400	400	115	70
M1E-800	800	262	210

Coefficient ratio due to environment temperature factor

Table 4

Type	Environment temperature factor	+40°C	+45°C	+50°C	+55°C	+60°C
		Coefficient ratio	Coefficient ratio	Coefficient ratio	Coefficient ratio	Coefficient ratio
M1E-125		1In	0.95In	0.89In	0.84In	0.76In
M1E-250		1In	0.96In	0.91In	0.87In	0.82In
M1E-400		1In	0.94In	0.87In	0.81In	0.73In
M1E-800		1In	0.88In	0.83In	0.79In	0.76In

6. Main Technical Specifications

Table 2

Type	M1E-125		M1E-250		M1E-400		M1E-800		
Frame current(InmA)	125		250		400		800		
Breaking capacity	M	H	M	H	M	H	M	H	
Rated current	32A(16,20,25,32)		100,125,140,160 180,200,225,250		200,225,250,280 315,350,400		630,640,660,680 700,720,740,760 780,800		
	125A(40,50,60,70, 80,90,100,125)								
Pole	3, 4		3, 4		3, 4		3, 4		
Rated insulating voltage	AC690V								
Rated operating voltage	AC400V								
Rated impulse withstanding voltage	6000V		8000V		8000V		8000V		
Rated frequency	50Hz								
Flashover distance	Top-down	≤ 50		≤ 50		≤ 80		≤ 80	
	Left-right	0		0		0		0	
	Front-back	0		0		0		0	
Using category	A		B		B		B		
Rated limiting short-circuit breaking capacity	50	65	50	70	65	85	65	85	
Rated service short-circuit breaking capacity	35	50	35	50	42	65	42	65	
Rated withstand short-circuit current	1.5	1.5	5	5	8	8	10	10	
Operating lift(time)	Electrical	1500		1000		1000		500	
	Mechanical	8500		7000		4000		3000	

7. Outline and Installation Dimension

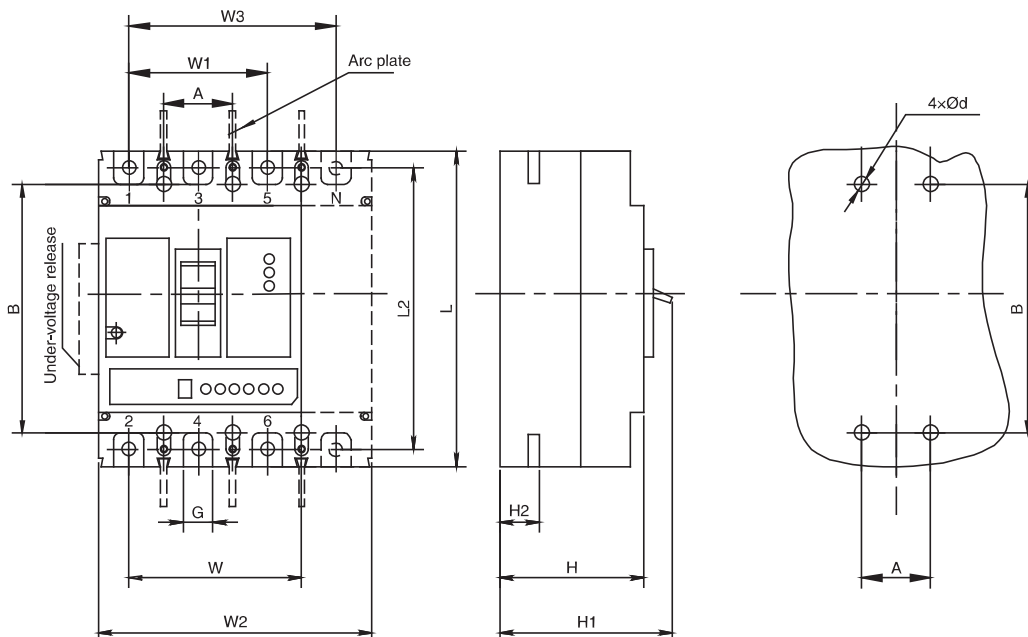

M1DC Series Moulded Case Circuit Breaker



M1DC-250/4300

1. Application

AM1 DC series DC moulded case circuit breaker is developed by advanced design and manufacturing technology, suitable for a the circuit of AC50/60Hz, rated voltage is DC250V, DC500V, DC750V and DC 1000V, rated current up to 400A, the circuit breaker have function of short circuit, overload and under-voltage protection to protect circuit and power equipment against damage. The breaker are comply with the IEC60947-1 and IEC60947-2.

2. Main Technical Specifications

Type	M1DC-100			M1DC-250			M1DC-400		
Frame current Inm(A)	100			250			400		
Rated current In (A)	10,16,20, 25, 32,40, 50,63, 80, 100			16, 20,25,32,40 , 50, 63, 80,100, 125, 140,160,180, 200, 225,250			250,315 350,400		
Pole number	2	3	4	2	3	4	3	4	
Rated insulation voltage Ui (V)	1000								
Rated impulse withstanding voltage Uimp(V)	8000								
Rated working voltage Ue(V)	DC250 DC500	DC500 DC750	DC750 DC1000	DC250 DC500	DC500 DC750	DC750 DC1000	DC500 DC750	DC750 DC1000	
Using category	A								
Isolation	o								
Arcing distance (mm)	≤ 50						≤ 100		
Rated short time making capacity Icm (kA)	100% Icu								
Rated limiting short-circuit breaking capacity Icu (kA)	DC250V	35			35				
	DC500V	20	35		20	35	50		
	DC750V		20	35		20	35	50	
	DC1000V			20			20	35	
Rated service short-circuit breaking capacity Ics (kA)	75% Icu								
Electrical life (times)	5000			5000			1000		
Mechanical life (times)	Without maintenance	10000			10000			5000	
	With maintenance	20000			20000			10000	

2. Main Technical Specifications

Shunt release	AC230V 400V DC24V~30V DC220V~250V
Under-voltage release	DC220~250V
Auxiliary contact	AC-15:AC400/0.3A DC-13:DC250V/0.15A
Alarm contact	AC-15:AC400/0.3A DC-13:DC250V/0.15A
Motor-driven operation device	AC110V 230V 400V DC24V~30V, DC110V~125V, DC220V~250V

3. Wiring diagram

Two pole circuit breaker

— C type connection

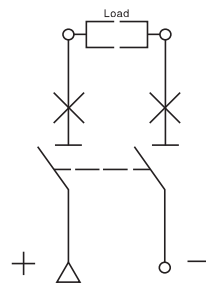

— D type connection

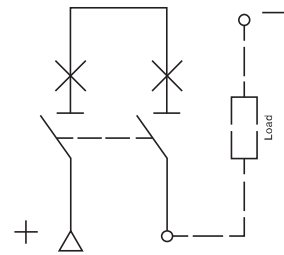

Three pole circuit breaker

— E type connection

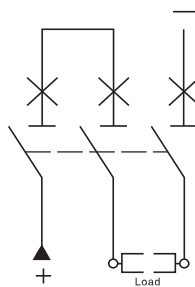

— F type connection

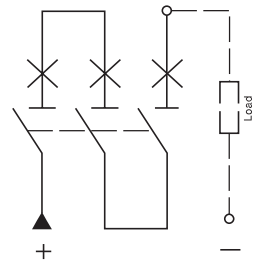

Four pole circuit breaker

— G type connection

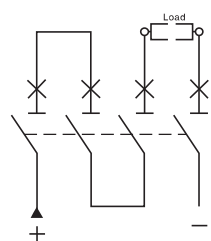

— H type connection

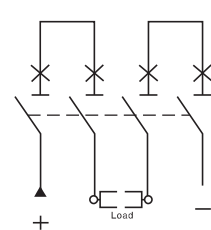

— I type connection

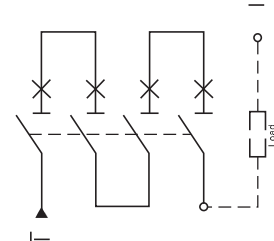

Power system suitable for above wiring diagram

Rated working voltage	Power/Load wiring type						Core point grounding system
	Ungrounding system		Negative pole grounding system				
DC250V	C		-	D			C
DC500V	E	-	D	E	-	-	C
DC750V	E	H	E	F	G	I	H
DC1000V	-	H	-	-	G	I	H

4. Application in DC Grounding system

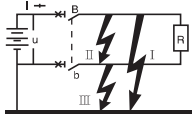
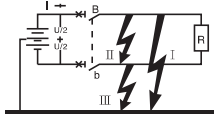
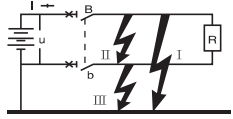
System category	Grounding system		No grounding system	
	Negative pole grounding	Core point grounding		
All of fault category				
Fault effect	Fault I	Producing the highest short-circuit current Breaking the positive pole contact connected to power	U/2voltage, producing the highest short-circuit current effect Breaking the positive pole contact connected to power	No effect
	Fault II	Producing the highest short-circuit current But the contacts in series are all breaking	Producing the highest short-circuit current But the contacts in series are all breaking	Producing the highest short-circuit current But the contacts in series are all breaking
	Fault III	No effect	the same as fault I, but breaking the negative pole contact connected to power	No effect
The most serious condition	Fault I	Fault I and fault III	Fault II	
Breaking pole condition	Can be in series on the positive pole, breaking both poles	With U/2, use breaking highest short-circuit current to each pole	Breaking both poles	

Wiring conduct selection

Rated current (A)	Section area (mm ²)	Rated current (A)	Section area (mm ²)
16, 20	2.5	125, 140	50
25	4	160	70
32	6	180, 200, 225	95
40, 50	10	250	120
63	16	315, 350	185
80	25	400	240
100	35		

5. Outline and Installation Dimension (mm)

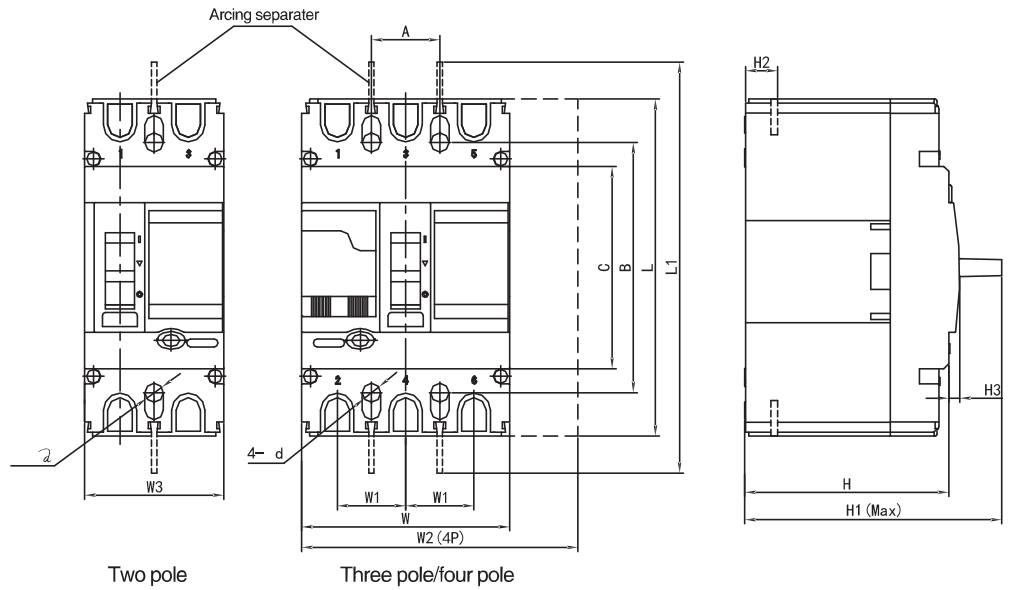

Remarks: The arcing separators are only installed between the phase lines

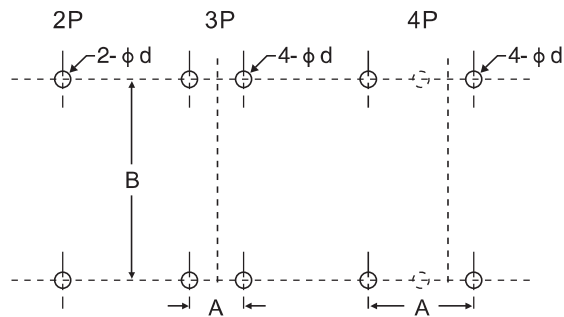

Type	M1DC-100			M1DC-250			M1DC-400		
	2P	3P	4P	2P	3P	4P	3P	4P	
Outline dimensions	C	87.5			102			129	
	H	87			103			105	
	H1	105			127			155	
	H2	24			24			38	
	H3	4			5.5			6.5	
	L	150			165			257	
	L1	250			360			457	
	W	75			107			150	
	W1	30			35			48	
	W2	100			142			198	
	W3	50			75			/	
Installation dimensions	A	/	30	60	/	35	70	44	88
	B	129			126			194	
	Φd	4.5			4.5			7	

M1L Series Earth Leakage Circuit Breaker

1. Application

M1L series earth leakage circuit breaker is one of the new type earth leakage breakers which has been developed by the company using international advanced design and manufacturing technology. Suitable for a line of AC50/60Hz, rated voltage up to 400V, rated current 16A to 630A. and is acted as infrequently changeover of circuit or infrequent starting of motor. The breaker has overload, short-circuit and under-voltage protective function, which can protect the circuit and the power equipment against damage, meanwhile, it can provide protection to these fire risk that caused by these long-time existed grounding fault that can not be detected by the over-current protection.

This breaker can be installed vertically (upright) or horizontally (transverse).

The wiring of the breaker can not be in adverse direction, that means power supply line must be connected to terminal 1,3 and 5, and the load line connected to terminal 2,4 and 6.

The rated residual operating current $I_{\Delta n}$ and the maximum breaking time can be adjusted on site according to practical condition.

The leakage protection module still can work normally when the phase voltage reduced to 50V. It has the same overall size with the AM1 series breakers, which make the installation more exchangeable.

The breakers are suitable for isolation, its symbol are: 

The breakers comply with the demands of the following standards:

IEC60947-1 and GB/T 14048.1 General

IEC60947-2 and GB 14048.2 Low voltage breakers

IEC60947-4 and GB 14048.4 Contactors and motor starters

IEC60947-5.1 and GB 14048.5 Electrical equipments of electromechanical control circuit



M1L-125L/4300A



M1L-250L/4300A



M1L-400L/4300A



M1L-630L/4300A

2. Main Technical Specifications

Table 1

Type	M1L-100	M1L-225	M1L-400	M1L-630	
Frame current I_{nm} (A)	100	225	400	630	
Rated current I_n (A)	(10)16,20,25,32,40,50,63,80,100	100, 125, 160, 180, 200, 225	225, 250, 315, 350,400	400, 500, 630	
Pole number	3 4	3 4	3 4	3 4	
Rated insulation voltage U_i (V)	AC800				
Rated working voltage U_e (V)	AC400				
Rated impulse withstand voltage U_{imp} (V)	8000				
Arc-over distance(mm)	≥50				
Breaking capacity grade	M H	M H	M	M	
Limiting short-circuit breaking capacity I_{cu} (kA)	50 85	50 85	50 65	65	
Service short-circuit breaking capacity I_{cs} (kA)	35 50	35 50	35 42	42	
Rated residual operating current $I_{\Delta n}$ (mA)	Non-delay type 100/300/500				
	Delay type 100/300/500			300/500/1000	
Rated residual non-operating current $I_{\Delta no}$ (mA)	1/2 $I_{\Delta n}$				
Operation performance (time)	Electrified	1500	1000	1000	1000
	Unelectrified	8500	7000	4000	4000

Note: According to the pole number of product, it classifies three and four poles. The neutral pole (N-Pole) of the four-poles products has four types:

Type A: N-pole without over-current release unit, it has been connected all the time, not closing and opening with the other three poles.

Type B: N-pole without over-current release unit, which closing and opening with the other three poles.

Type C: N-pole fixed with over-current release unit, which closing and opening with the other three poles.

Type D: N-pole fixed with over-current release unit, it has been connected all the time, not closing and opening with the other three poles.

1. The limiting breaking and arc-over distance includes horizontal and vertical installation.
2. If the three-pole breaker of this series is connected with three phase load, the load can not have neutral line, otherwise the breaker will have fault action.
3. If the three-pole breaker of this series is connected with single phase load, the phase line will be connected to the left pole, and the neutral line is connected to the right pole, the middle pole is blanket

3. Protection Characteristic

The thermal release of the breaker has again-time-limit property; the electromagnetic release is inst. Operation, its property see table 2(for distribution),table 3 (motor protection). Table 2

Rated current of release(A)	Thermal release (ambient temperature +40°C)		Electromagnetic release tripping current(A)
	1.05I _n (cold state) non-trip time (h)	1.03I _n (hot state) trip time (h)	
10 ≤ I _n ≤ 63	1	1	10I _n ± 20%
63 ≤ I _n ≤ 125	2	2	
125 ≤ I _n ≤ 630	2	2	5I _n ± 20% 10I _n ± 20%

Table 3

Rated current of release	Thermal release (ambient temperature +40°C)				Electromagnetic release tripping current(A)
	1.0I _n (cold state) non-trip time (h)	1.20I _n (hot state) trip time(h)	1.50I _n (thermal state) trip time	7.2I _n (cold state) trip time	
10 ≤ I _n ≤ 400	2	2	8min	6s < T _p ≤ 20s	12I _n ±20%

4. Residual Current Operating Time of Earth Leakage Circuit Breaker

4.1 Non-delay type operation characteristics see table 4(I_{Δn} < 30mA should be Non-delay type)

Table 4

Rated current		I _{Δn}	2I _{Δn}	5I _{Δn}	10I _{Δn}
Non-delay type	Max.breaking time(s)	0.3	0.15	0.04	0.04

Note: ^ato I_{Δn} < 30mA earth leakage circuit breaker, 0.25A can instead of 5I_{Δn}
According to^a, adopt 0.25A, then 10 I_{Δn} is 0.5A.

4.2 Delay type operation characteristics see table 5

Limiting non-driven time of delay type earth leakage circuit breaker according to 2I_{Δn}, operation characteristics see table 5

Table 5



Back panel connection

Delay time (s)	Max. breaking time(s) at $1 \Delta n$	Limiting non-driven time (s) at $2I \Delta n$	Max. breaking time(s)	Max. breaking time(s) at $5I \Delta n$	Max. breaking time(s) at $10I \Delta n$
0.1	0.4	0.06	0.2	0.15	0.15
0.2	0.5	0.06	0.2	0.15	0.15
0.3	0.6	0.1	0.4	0.3	-
0.4	0.7	0.2	0.5	0.4	-
0.5	0.8	0.3	0.6	0.5	-
0.6	0.9	0.4	0.7	0.6	-
0.7	1.0	0.5	0.8	0.7	-

5 .Accessories of Circuit Breaker

5.1 The external accessories of the breaker

- Electromagnetic operation device and Motor-driven operation device

1) Wiring diagram of type CDM electromagnetic operation device(fitting AM1L-100,225) see the following drawing (wiring diagram of the external accessories of the breaker in the dotted frame)



Electromagnetic operation device

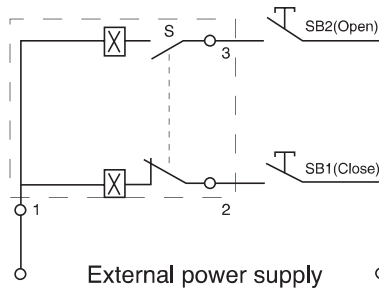

2) Wiring diagram of type CD motor-driven operation device (fitting AM1L-400,630) see belows (wiring diagram of the external accessories of the breaker in the dotted frame)

Code description: SB1, SB2 stand for push button.(provided by users themselves)

Number "1"、"2"、"3" stand for number of wiring terminals.

Voltage rating: AC230V、400V, DC 220V



Motor-driven operation device

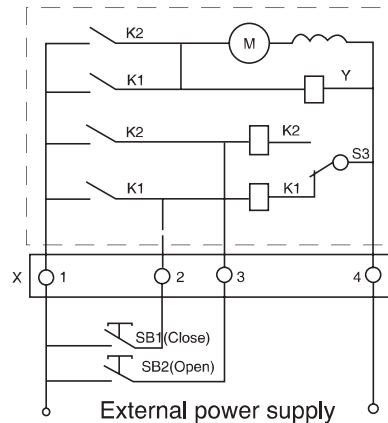

Code description: SB1, SB2 stand for push button. (provided by users)

"X" stands for line connection terminals

Voltage rating: AC50Hz 230V、400V; DC220V



Rotary handle operation device

● **Rotary handle operation device**

The mechanism is used with moulded case circuit breaker to operate the draw-out panel. Power distribution panel and supply box outside the panel by turning the handle ,and to ensure the door of panel would not be opened when the breaker being on.

The hand-drive mechanism can be equipped with two types of operation one is “A” model square handle , the another is “B” model round handle.

5.2 The Internal Accessories of the Breaker

5.2.1 Release pattern and accessories code see following table

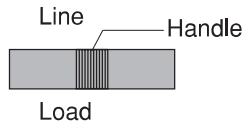

SHT: Shunt release; UVR: Under-voltage release;
AX: Auxiliary contact; AL: Alarm contact



Under-voltage release

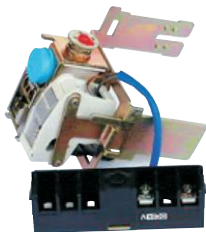

Shunt release



Alarm contact



Auxiliary contact

Release pattern and accessories code	Name	Type	M1L- 100, 225	M1L-400	M1L-630
			200, 300	Without accessories	200: Magnetic release (only short circuit protection) 300: Thermal magnetic release(both overload and short circuit protection)
208, 308	Alarm contact		AL	AL	AL
210, 310	Shunt release		SHT	SHT	SHT
220, 320	Auxiliary contact		AX	AX	AX
230, 330	Under-voltage release		UVR	UVR	UVR
228, 328	Auxiliary contact, Alarm contact		AL AX	AL AX	AL AX

5.2.2 The technical parameter and functions of the accessories

Accessory	Rated operating voltage (V)			
	AC50/60Hz		DC	
Shunt release Us	220(230)	380(400)	110	220
Under-voltage release Us	220(230)	380(400)		

Auxiliary contact and Alarm contact: Auxiliary contact is as same as Alarm contact , the technical parameter see following table

Rated thermal current Ith (A)	Rated operating current Ie(A)		Suited Frame Inm(A)
	AC380V	DC220V	
3	0.3	0.15	100, 225
3	0.4	0.15	400, 630

Accessory	Function	Wiring connection diagram
Alarm contact	Indicate circuit breaker at tripping	<p>The position of breaker at opening and closing</p>
Auxiliary contact	Indicate circuit breaker at opening or closing	<p>The position of breaker at opening</p>
Shunt release	The shunt release should make the breaker trip reliably when the operation voltage is 70%-110% of rated control voltage	<p>The micro switch will cut by itself when breaker open</p>
Under-voltage release	When Ue is 35%-70% of the rated control voltage, the under voltage release should make the breaker trip correctly When Ue is 85%-110% of the rated control voltage, the under voltage release should make the breaker close In case of Ue less than 35%of the rated control voltage should prevent the breaker from closing	

6. Outline and Installation Dimension(mm)

Type	Outline dimensions																				Installation dimensions		
	Front panel connection								Back panel connection				Plug-in connection										
	W	L	H	W1	L1	L2	H1	H2	L3	H3	D	L4	L5	H4	H5	H6	C	D	D1	A	B	d	
M1L-100M,H/3P	92	150	92	60	200	132	110	28.5	90	93	22	168	92	50	64	76	56	60	6.5	30	129	4.5	
M1L-100M,H/4P	122	150	92	90	200	132	110	28.5	90	93	22	168	92	50	64	76	56	90	6.5	30	129	4.5	
M1L-225M,H/3P	107	165	90	70	265	144	110	24	93	100	24	183	94	50	71.5	86.5	54	70	6.5	35	126	5.5	
M1L-225M,H/4P	142	165	103	105	265	144	110	24	93	100	24	183	94	50	71.5	86.5	54	105	6.5	35	126	5.5	
M1L-400M,H/3P	150	257	106.5	96	441	224	146.5	38	164	108.5	32	279	-	60	83.5	106.5	70	105	8.5	44	194	7	
M1L-400M,H/4P	198	257	106.5	144	441	224	146.5	38	164	108.5	32	279	-	60	83.5	106.5	70	129	8.5	44	194	7	
M1L-630M,H/3P	210	280	115.5	145	480	243	155	45.3	158	84	48	296	-	61	97	148	140	143	10	70	243	7	
M1L-630M,H/4P	280	280	115.5	210	480	243	155	45.5	158	84	48	296	-	61	97	148	140	210	10	70	243	7	

Front panel connection

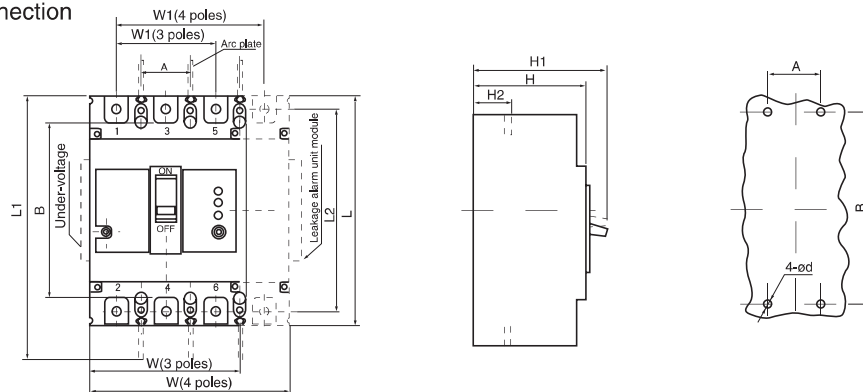

Back panel connection

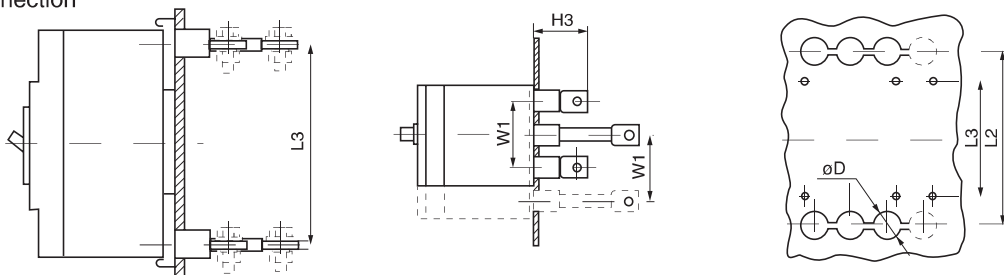

Plug-in connection

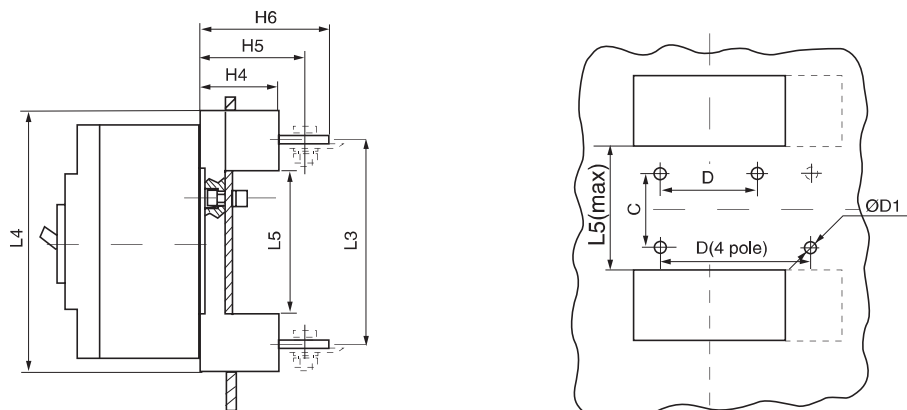

M1/MS1-40L Series Moulded Case Circuit Breaker



M1/MS1-40L

1. Application

M1/MS1 series molded case circuit breaker is Economic type of M1 Type. It is suitable to the circuit of AC 50Hz, rated voltage up to 380V, rated current up to 63A, used as the protection of over load, short circuit and the non frequent start of motor. Complies with GB140048.2, GB14048.4, IEC60947-2 and IEC60947-4 standards.

M1/MS1 MCCB operation mechanism has obviously close and break swiftly. The contact is AgZnO, the contact resistance is small, abrasion resistant, anti fusion welding, the long time delay release adopt oil damping hydraulic type release, ideal time-inverse protection feature can be supplied.

2. Main Technical Specification

Type		M1/MS1-40	M1/MS1-63
Un(V)		AC 380/220	
Inm(A)		40	63
Pole		3	
In(A)		6,10,16,20,25,32,40	50,63
Electrical life(times)	With load	1500	
	No load	8500	
	Total	10000	
Operation Time/Hour		120	
Over current tripping feature	1.05I _H	Not trip within 1 hour	Cool status
	1.3I _n	Trip within 1 hour	Thermal status
	3.0I _n	Return time ≥ 2s	Cool status
	10I _N	≤ 2s trip	Cool status

Remark: Frame current > 63A, default tripping time or not tripping time is 2 hour.

3. Normal Working Conditions and Installation Condition

1. Maximum ambient air temperature does not exceed 40°C, and the minimum is not less than -5°C. The average temperature does not exceed 35°C within 24h;

Note 1: When the lower limit is -10°C or -25°C, users should state to manufacturer when ordering.

Note 2: When the upper limit is more than +55°C or the lower limit is less than -25°C, users should negotiate with the manufacturer.

2. The altitude of installation site does not exceed 2000m;

3. Relative humidity of the surrounding air temperature is less than 50% at 40°C. At a lower temperature, it can be a higher relative humidity. For example at 20°C, it is up to 90%. When it occurs the occasional condensation due to temperature changes, appropriate measures should be taken.

4. Pollution degree: Class 3;

5. Installation category: Main circuit of circuit breaker is Class III. Control and auxiliary circuits are Class II.

M2 Series Moulded Case Circuit Breaker



M2-100N/3P



M2-250N/3P



M2-400N/3P



M2-630N/3P

1. Application

M2 series moulded case circuit breaker is one of the breakers which adopts international advanced design, manufacture technology to develop. The rated insulating voltage is 750V, suitable for the circuit of AC 50/60Hz, rated working voltage 690V or below, rated working current is 12.5A to 1600A and used in distributing electric energy, and infrequently breaking in the normal conditions, protecting the circuit & equipment from overload & under voltage, circuit breaker with rated frame current 400A or below, can be used in mousecage motor's infrequent start, breaking during working, protecting motor from overload, short circuit & undervoltage, the product conforms to IEC60947-2 standard.

2. Main Technical Specifications

Table 1

Type	Pole	Rated insulating voltage (V)	Rated operating voltage (V)	Rated ultimate short circuit breaking capacity Icu (kA) at 380/415V	Rated service short circuit breaking capacity Ics at 380/415V(kA)	Operation performance		Utilization category			
						ON	OFF				
M2-100N	3, 4 pole	750	690 or below	25	25	1500	8500	A			
M2-100H				70	70						
M2-100L				150	150						
M2-160N				36	36	1000	7000				
M2-160H				70	70						
M2-160L				150	150						
M2-250N				36	36	1000	7000				
M2-250H				70	70						
M2-250L				150	150						
M2-400N				3 pole			45		45	1000	4000
M2-400H							70		70		
M2-400L							150		150		
M2-630N	45	45	1000				4000				
M2-630H	70	70									
M2-630L	150	150									
M2-1250N				50	37.5	1000	4000				
M2-1600N				50	37.5						

Note:1. The N-pole breaker which closing and opening with the other three poles no protection.

3 Main Technical Parameter of Trip Units

Thermal magnetic release

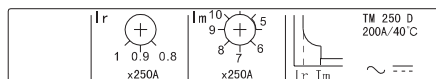

Type	Rated current In(A)	Note
M2-100	12.5,16,20,25,32,40,50,63,80,100	T adjustable (0.8~1In) M adjustable (5~10In)
M2-160	16,20,25,32,40,50,63,80,100,125,160	
M2-250	160, 180, 200, 225, 250	
M2-400	315, 350, 400	
M2-630	400, 500, 630	
M2-1250	800, 1000, 1250	T adjustable (0.8~1In) M fixed
M2-1600	1000, 1250, 1600	

● **Electronic release**

M2 22SE: protection of low-voltage distribution networks for M2-100\160\250



M2-250N/4P

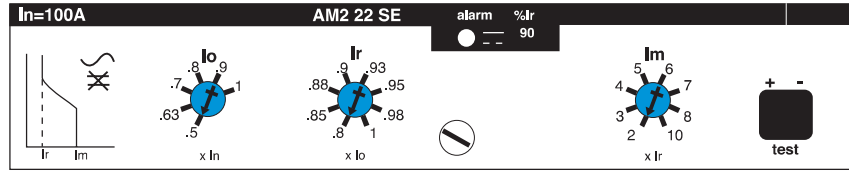

1. Overload protection with adjustable threshold
2. Short-circuit protection with adjustable threshold
3. Load indication : light at 90% of Ir setting threshold;
Flashing at 105% or more of Ir setting threshold

Type	Rated current In(A)	Note
M2-100	40, 100	$I_r = 0.4 \dots 1 \times I_n$ (adjustable 48 setting) Tripping between $1.05 \dots 1.3 \times I_r$ (IEC60947-2) (Long-time overload protection) $I_m = 2-3-4-5-6-7-8-10 \times I_r$ (Short-circuit protection)
M2-160	40, 100, 160	
M2-250	40, 100, 160, 250	



M2-630N/4P

M2 22ME: protection of motor for AM2-100\160\250

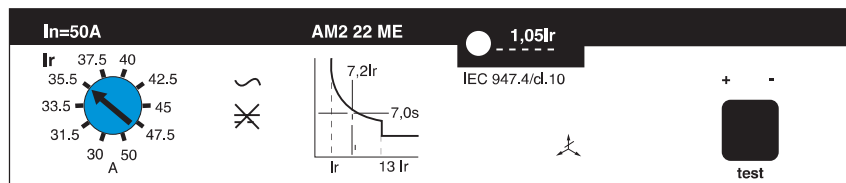

1. Overload protection with adjustable threshold, as defined by IEC60947-4 (2) tripping class 10
2. Short-circuit protection with fixed threshold ($13 \times I_r$)
3. phase failure protection (tripping time delay between 3.5s-6s)
4. Load indication : dark less than 105% of Ir setting threshold;
Flashing at 105% or more of Ir setting threshold

Type	Rated current In(A)	Note
M2-100	40, 50, 80, 100	$I_r = 0.6-0.63-0.67-0.71-0.75-0.80-0.85-0.90-0.95-1 \times I_n$
M2-160	40, 50, 80, 100, 150	
M2-250	40, 50, 80, 100, 150, 220	

M2 23SE: protection of low-voltage distribution networks for AM2-400\630



M2-800N

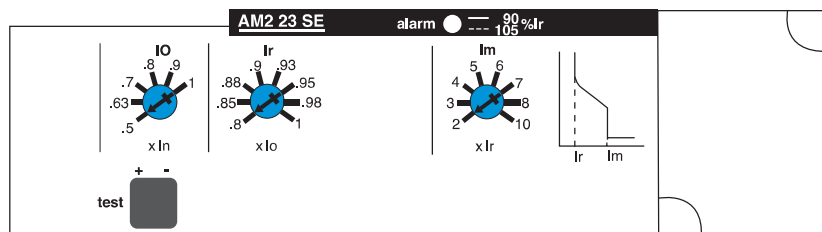

1. Overload protection with adjustable threshold
2. Short-circuit protection with adjustable threshold
3. Load indication : light at 90% of Ir setting threshold;
Flashing at 105% or more of Ir setting threshold

Type	Rated current In(A)	Note
M2-400	400	$I_r = 0.4 \dots 1 \times I_n$ (adjustable 48 setting) Tripping between $1.05 \dots 1.3 \times I_r$ (IEC60947-2) (Long-time overload protection) $I_m = 2-3-4-5-6-7-8-10 \times I_r$ (Short-circuit protection)
M2-630	630	

M2 53UE: protection of low-voltage distribution networks for M2-400\630

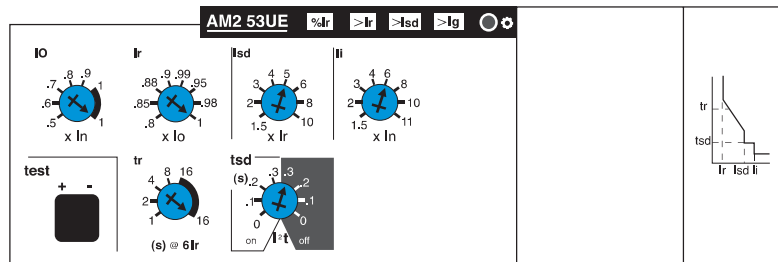

1. Overload protection with adjustable threshold, as defined by IEC60947-2
2. Short-circuit protection with adjustable threshold
3. Instantaneous short-circuit protection
4. Earth fault protection with adjustable threshold
5. Load indication : light at 90% of I_r setting threshold;
Flashing more than I_r setting threshold
6. Fault indication

LEDs indicates the type of fault that caused tripping

Overload (**LT** protection) or abnormal component temperature (**>Ir**);

Short-circuit (**ST** or instantaneous protection)(**>Im**);

Earth fault (if earth fault protection option is present)(**Ig**);

Microprocessor malfunction (both **>Ir** and **>Im**) LEDs go on ,plus the (**Ig**) LEDs if earth fault protection option is present)

Battery powered. Spare battery are supplied in an adapter box. When a fault occurs , the LED indicating the type of fault ,lights for about 10 minutes . The information is however stored in memory . The LED can be illuminated by pressing the test pushbutton. The LED automatically goes off and the memory is cleared when the circuit breaker is reset .

Type	Rated current In(A)	Note
M2-400	400	$I_r = 0.4 \dots 1 \times I_n$ (adjustable 48 setting) Tripping between $1.05 \dots 1.3 \times I_r$ (IEC60947-2) at $6 \times I_r$ Trip time: 1s, 2s, 4s, 8s, 16s(adjustable) (Long-time overload protection) $I_{std} = 1.5-2-3-4-5-6-7-8-10 \times I_r$ Trip time: 0s, 0.1s, 0.2s, 0.3s adjustable+ I^2t (Short-circuit short time delay protection) $I_i = 1.5-2-3-4-6-7-8-10-11 \times I_r$ (Instantaneous short-circuit protection) $I_g = 0.1-0.2-0.3-0.4-0.5-0.6-0.7-0.8-1 \times I_r$ Trip time: 0.1s, 0.2s, 0.3s, 0.4s adjustable+ I^2t (Earth fault protection) (If option is present)
M2-630	630	

M2 43ME: protection of motor for M2-400\630



1. Overload protection with adjustable threshold, as defined by IEC60947-4 (2) tripping class 10A,10 and 20
2. Short-circuit protection with adjustable threshold (6...13xIr)
3. Phase failure protection (built-in electronic release: operates unbalanced single-phase current at 40% and more than) (tripping time delay $4s \pm 10\%$), as defined by IEC60947-4.1
4. Load indication : Flashing more than Ir setting threshold
5. Fault indication

LEDs indicates the type of fault that caused tripping
 Overload (**LT** protection) or abnormal component temperature (**>Ir**);
 Short-circuit (**ST** or instantaneous protection) (**>Im**);
 Phase failure (**right LED**);

Microprocessor malfunction (**>Ir**) (**>Im**) and phase failure LEDs all go on)

Battery powered. Spare battery are supplied in an adapter box. When a fault occurs ,the LED indicating the type of fault ,lights for about 10 minutes . The information is however stored in memory . The LED can be illuminated by pressing the test pushbutton. The LED automatically goes off and the memory is cleared when the circuit breaker is reset .

Type	Rated current In(A)	Note
M2-400	400	Ir=0.4...1 × In(adjustable 48 setting) Trip degree: class 10A, 10,20(IEC60947-4) (Long-time overload protection) Im=6-7-8-9-10-11-12-13 × Ir (Short-circuit protection)
M2-630	630	



4. Accessories

Accessories	Rated operating voltage	Consumption		For type
		Pick-up	Seal-in	
Shunt release (MX)	24V	<10VA	<5VA	AM2-100~630
	100V			
Under-voltage release (UN)	220/230V	<10VA	<5VA	AM2-100~630
	380/400V			
Accessories	Rated operating voltage	Rated operating current		For type
		AC12	AC15	
Auxiliary contact (OF)	380/400V	6	3	AM2-100~630
Alarm contact (AL)	380/400V	6	3	

Rotary handle

● **Direct rotary handle**

Degree of protection:IP40

Function: 1) suitability for isolation

2) indication of three positions 0(off) I(on) and tripped

3) press “push to trip” button, can trip-free

4) visibility of and access to trip unit settings

5) the circuit breaker can be locked in the off position by one to three padlocks , diameter 5 to 8mm(not supplied)



Rotary handle

● **Extended rotary handle**

Degree of protection:IP55

Function: 1) Suitability for isolation

2) Indication of three positions 0(off) I(on) and tripped

3) Visibility of and access to trip unit settings when the door is open

4) Door opening prevented when circuit breaker is on

5) The circuit breaker can be locked in the off position by one to three padlocks , diameter 5 to 8mm(not supplied).Locking prevents opening of the switchboard door

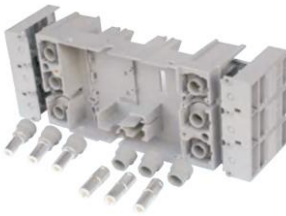

Plug-in base

5. Installation: Circuit breaker may be mounted vertically, horizontally or flat on their back without any derating of characteristics.

6. Fix: Mounting on backplate , mounting on rails

7. Connection: Front panel connection , back panel connection , plug-in connection

8. Outline and Installation Dimension

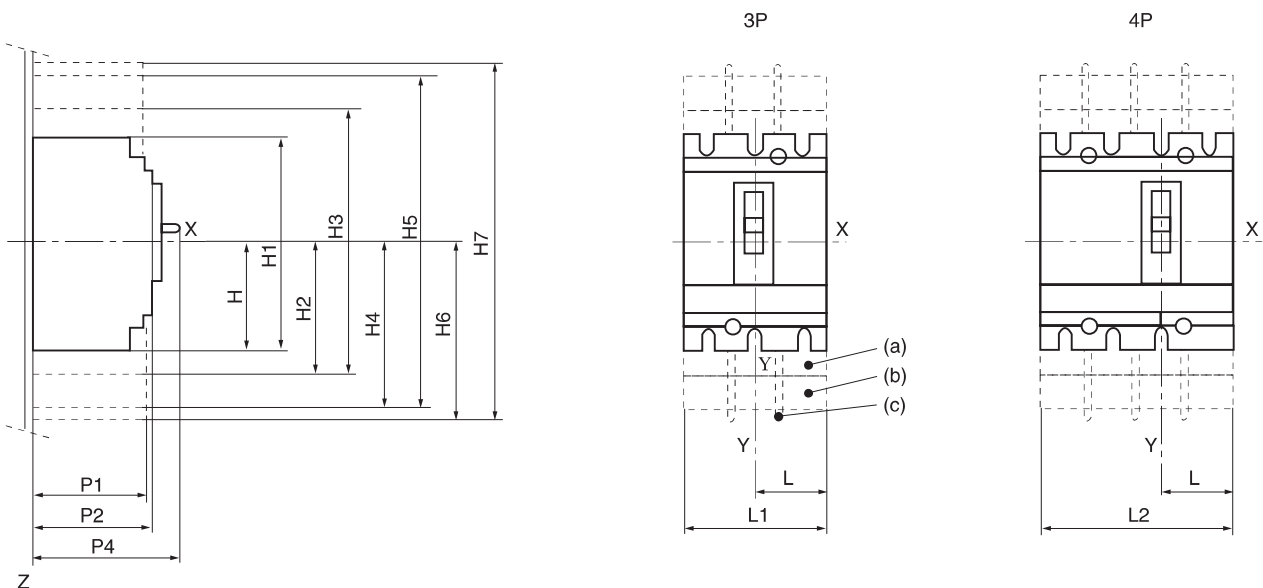

Mounting on backplate
3P

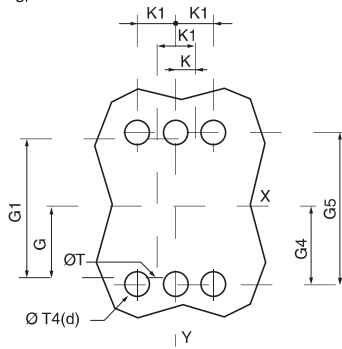

4P

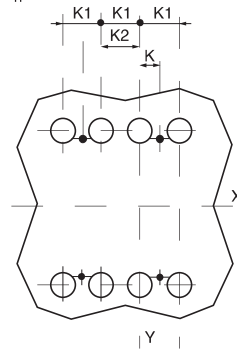

Mounting on rails
3P

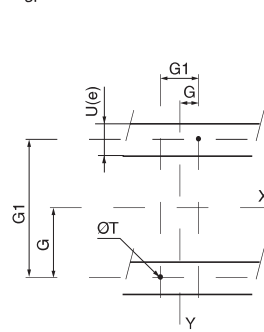

4P

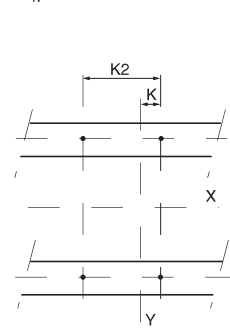

Aperture on a front panel

Fitting to fixed and plug-in circuit breaker

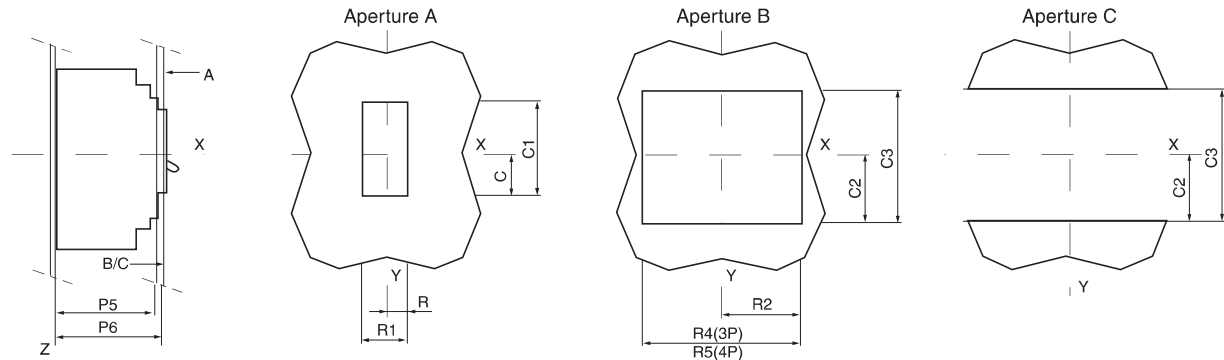

M2-100~630

Unit: mm

Type	C	C1	C2	C3	G	G1	G4	G5	H	H1	H2
M2 100/160/250N/H/L	29	76	54	108	62.5	125	70	140	80.5	161	94
M2 400/630N/H/L	41.5	116	92.5	184	100	200	113.5	227	127.5	255	142.5
M2 1250/1600N									100	255	

Type	H3	H4	H5	H6	H7	K	K1	K2	L	L1	L2	P1	P2	P4	P5
M2 100/160/250N/H/L	188	160.5	321	178.5	357	17.5	35	70	52.5	105	140	81	86	111*	83
M2 400/630N/H/L	285	240	480	237	474	22.5	45	90	70	140	185	95.5	110	168	107
M2 1250/1600N						99.5	199	209	99.5	199	269	107.5		205	

Type	P6	R	R1	R2	R4	R5	ØT	ØT4	(Ue)
M2 100/160/250N/H/L	88	14.5	29	54	108	143	6	22	≤ 32
M2 400/630N/H/L	112	31.5	63	71.5	143	188	6	32	≤ 32
M2 1250/1600N							6.5		

* P4=126 is suitable for M2 250N/H/L

M3 Series Moulded Case Circuit Breaker



M3-125L/3P



M3-250L/3P



M3-400L/3P



M3-630L/3P

1. Application

M3 series moulded case circuit breaker is applicable for the circuit of AC 50/60Hz, rated insulation voltage 690V (M3-125 500V), rated operating voltage AC 690V or below ,rated operating current 12.5-1600A, for distribute energy of electric and infrequently making and breaking circuit in normal conditions. The circuit-breakers are provided with the function of the protection against overload, short circuit and under-voltage. The circuit breakers comply with standard of IEC60947-2. The circuit-breakers are double insulating ($I_{nm}=250A$ or above), the control circuit of the accessories is set apart with the main circuit , and doesn't need to open the cover of the circuit breaker when install the accessories.

2. Specification

Table 1

Type	Pole number	Rated insulating voltage (V)	Rated operating voltage (V)	Ultimate short circuit breaking capacity $I_{cu}(kA)$		Rated short-circuit service breaking capacity $I_{cs}(\%I_{cu})$	Utilization category
				AC380V (400)	AC660V (690)		
M3-125L	1,2, 3,4	500	500	25	-	50%	A
M3-160L	3, 4	690	690 and below	35	8	75%	
M3-160M				50	10	75%	
M3-250L				35	14	100%	
M3-250M				65	18	75%	
M3-400L				35	18	100%	
M3-400M				65	22	100%	
M3-630L				35	20	100%	
M3-630M				50	22	100%	
M3-800L				35	20	100%	
M3-800M				50	22	100%	
M3-1250L	3	800	690 and below	50	20	100%	
M3-1600L				50	20	100%	

3. Main Technical Parameter of Trip Units (See Table 2)

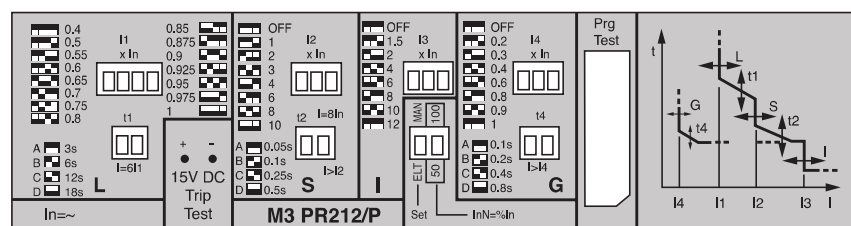
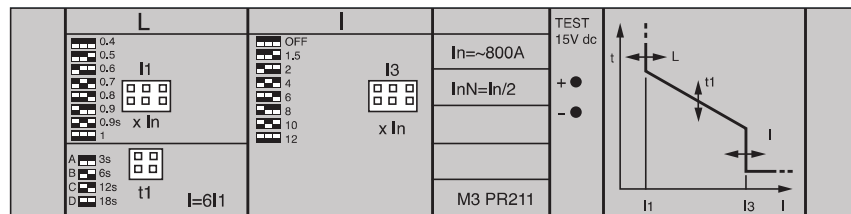

Table 2

Type	Thermal magnetic release		Electronic release	
	Rated current In(A)	Note	Rated current In(A)	Note
M3-125	12.5,16,20,25,32,40, 50,63,80,100,125	T fixed M fixed	-	
M3-160	16,20,25,32,40,50, 63,80,100,125,160	T adjustable (0.7~1In) M fixed	-	
M3-250	100,125,160,180, 225,250	T adjustable (0.7~1In) M fixed	-	
M3-400	225,250,315, 350,400	T fixed or adjustable (0.7~1In) M fixed	320,400	I1=0.4...1 × In M3 PR211(L-LI) I1=0.4...1 × In M3 PR212(LSI-LSIG) Tripping between 1.05...1.3 × I1 (IEC60947-2) I _t =constant (Long-time overload protection)
M3-630	400,500,630	T fixed M fixed	630	I2=1-2-3-4-6-8-10 × In t2=0.05s, 0.1s, 0.25s, 0.5s adjustable (Short-circuit short time delay protection)
M3-800	630,700,800	T fixed M fixed	800	I3=1.5-2-4-6-8-10-12 × In (Instantaneous short-circuit protection)
M3-1250	-	-	800,1000, 1250	I4=0.2-0.3-0.4-0.6-0.8-0.9-1 × In t4= 0.1s, 0.2s, 0.4s, 0.8s adjustable (Earth fault protection)
M3-1600	-	-	1000,1250, 1600	

Note: T-thermal M-magnetic L-long time S-short time relay I-instantaneous G-earth fault
AM3-125/160 In=12.5,16,20,32,40 magnetic protection that is fixed at 500A.

4. Accessories

4.1 The external accessories of the breaker

- Electromagnetic operation device and Motor-driven operation device

1) Wiring diagram of type CDM electromagnetic operation device(fitting M3-125,160,250) see the following drawing (wiring diagram of the external accessories of the breaker in the dotted frame)

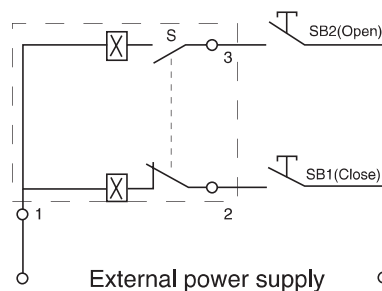

Code description: SB1, SB2 stand for push button.(provided by users themselves)

Number “1”、 “2”、 “3” stand for number of wiring terminals.

Voltage rating: AC50Hz 230V、 400V, DC 220V

2) Wiring diagram of type CD motor-driven operation device (fitting M3-400、 630、 800) see belows (wiring diagram of the external accessories of the breaker in the dotted frame)



Plug-in base



Electromagnetic operation device



Motor-driven operation device



Rotary handle



Shunt release



Under-voltage release



Alarm contact

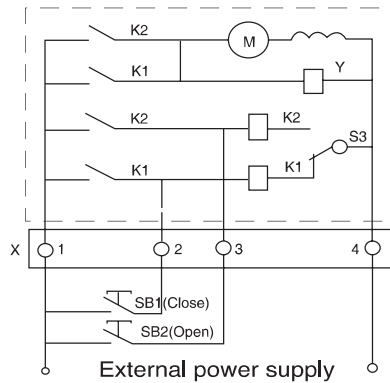

Code description: SB1, SB2 stand for push button. (provided by users)

“X” stands for line connection terminals

Voltage rating: AC 230V、400V; DC220V

● **Rotary handle**

Economic extended rotary handle

Degree of protection:IP30

Function: 1) With indication of isolation

2) Indication of three positions 0(off) I(on) and tripped

3) Door opening prevented when circuit breaker is on

4.2 The internal accessories of the breaker

● **Under-voltage release**

Us: AC 400V, 230V

When the operation voltage is 35%~70% of the rated voltage, the under-voltage release should make the breaker trip correctly.

When the operation voltage is 85%~110% of the rated voltage, the under-voltage release should make the breaker close.

In case of the operation voltage less than 35% of the rated voltage, the under-voltage should prevent the breaker from closing.

Note: Only the under-voltage release should be energized in advanced, the breaker could be re-cramped and turned-on, otherwise the breaker will be damaged.

● **Shunt release**

Us: AC230V 400V; DC110V 220V

The shunt release should make the breaker trip reliably when the operation voltage is 70%~110% of the rated control voltage

● **Auxiliary Contact**

When the breaker is in “off”	F14 _____ F12 _____		Size 2N/O+2N/C 1N/O+1N/C
	F24 _____ F22 _____		
When the breaker is in “on”	F14 _____ F12 _____		When the breaker is in “off”, the contacts switch from “close” to “open”. When the breaker is in “on”, the contacts switch from “open” to “close”

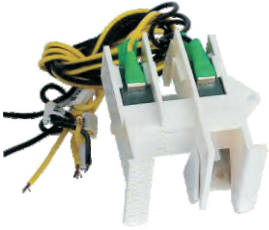

Auxiliary Contact

● Alarm contact

The position of the breaker in "off" or "on"	
The position of the breaker in "free release" (alarm)	B ₁₁ and B ₁₂ switch from "close" to "open", status of B ₁₁ and B ₁₄ switch from "open" to "close"

Auxiliary contact and Alarm contact: Auxiliary contact is as same as Alarm contact , the technical parameter(see table 3)

Table 3

Rated heating current I _{th} (A)	Rated operating current I _e (A)		Suited Frame I _{nm} (A)
	AC 380V	DC 220V	
3	0.3	0.15	125, 160
3	0.4	0.15	250, 400
3	0.4	0.15	630, 800,1250, 1600

5. Installation: Circuit breaker may be mounted vertically, horizontally or flat on their back without any derating of characteristics.

6. Fix: Mounting on backplate.

7. Connection: Front panel connection , black panel connection , plug-in connection

8. Outline and Installation Dimension

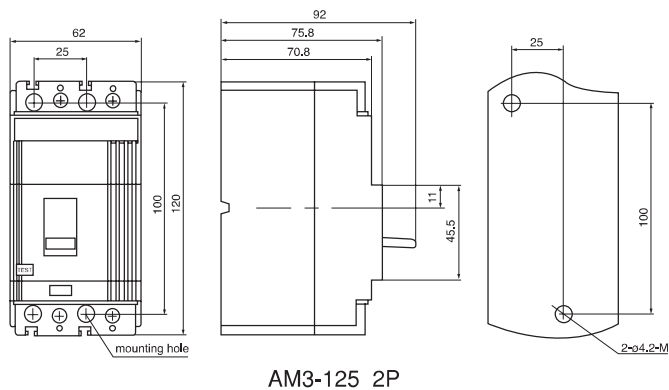
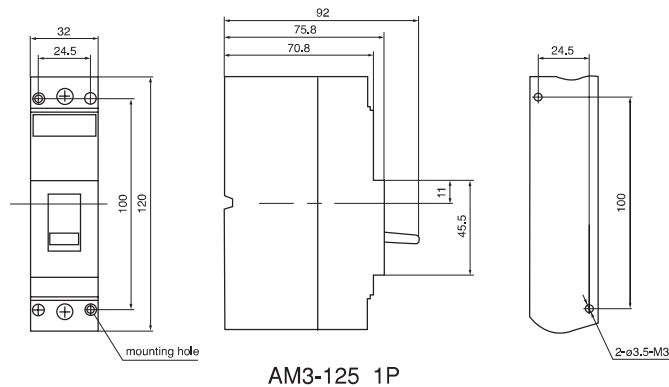

8. Outline and Installation Dimension (mm)

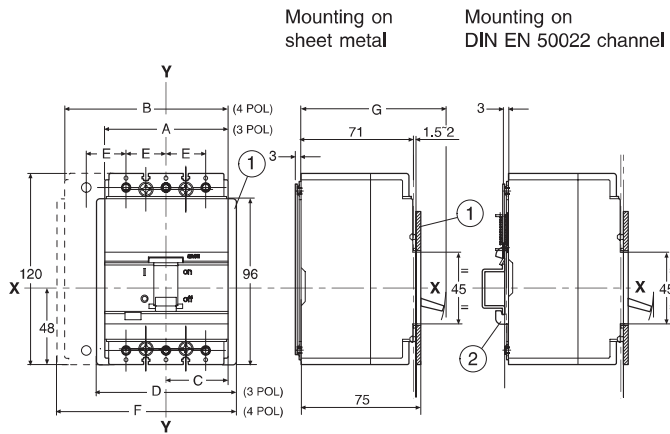

	A	B	C	D	E	F	G
M3-125	78	103	39	91	25	116	91
M3-160	90	120	45	103	30	133	93

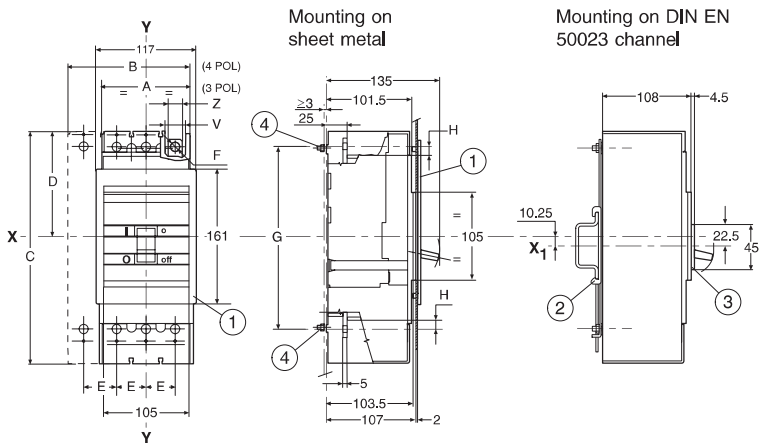

	A	B	C	D	E	F	G	H
M3-250	105	140	170	87.25	35	∅8	143	10
M3-400	140	183.75	254	125.25	143.75	∅10	218	12

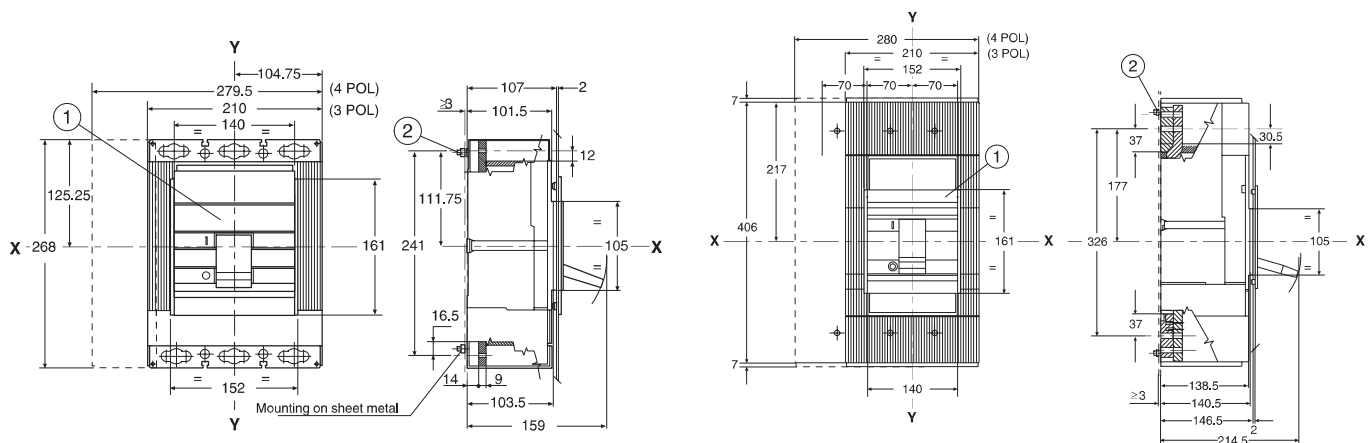

M3-630/AM3-800

M3-1250/AM3-1600

M9 Series Moulded Case Circuit Breaker



M9-53S

1. Application

M9 series MCCB is suitable for industrial or commercial power and lighting with AC50/60Hz, rated working voltage up to AC600V/DC250V, rated current up to 630A. It's a kind of economical breaker with the characters of stable and reliable function, beautiful appearance, small size and long life. It can be used for conversion of line and infrequently starting motor. It can also be attached to install the accessories which have protection function for avoiding loss voltage, undervoltage. The product can connect line with front board and back board, it also can be equipped with hand-operating apparatus or motor-operating apparatus to control in a remote distance.

2. Specification

The rated insulation voltage for this series of circuit breaker is 690V, the rated operating voltage is 600V, the rated frequency is 50/60Hz, the other rated values for the main circuit.



M9-103S

Type	2pole	M9-32E	M9-52E	M9-52S	M9-62E	M9-62S
	3pole	M9-33S	M9-53E	M9-53S	M9-63E	M9-63S
Frame size(AF)		30	50		60	
Rated current(A)		5,10,15,20,30	5,10,15,20,30,40,50		60	
Rated operational voltage(V)Ue (50/60Hz)		600	600	600	600	600
Rated insulation voltage(V)Ui(50/60Hz)		690	690	690	690	690
Rated impulse withstand voltage(kV)Uimp		6	6	6	6	6
Ultimate breaking capacity (kA,Icu AC 50/60Hz)	220V/240V	10	10	25	10	25
	380V	7.5/5	7.5/5	14/10	7.5/5	14/10
	415V	7.5/5	7.5/5	14/10	7.5/5	14/10
	440/460V	5	5	10	5	10
	480/500V	2.5	2.5	7.5	2.5	7.5
	600V	2.5	2.5	5	2.5	5
Utilisation category		A	A	A	A	A
Endurance	Mechanical	8500	8500	8500	8500	8500
	Electrical	1500	1500	1500	1500	1500



M9-203S

Type	2pole	M9-102E	M9-102S				
	3pole	M9-103E	M9-103S	M9-203E	M9-203S	M9-403E	M9-403S
Frame size(AF)		100		225		400	
Rated current(A)		5,10,15,20,30,40,50,60,75,100	15,20,30,40,50,60,75,100	100,125,150,175,200,225		250,300,350,400	
Rated operational voltage(V)Ue (50/60Hz)		600	600	600	600	600	600
Rated insulation voltage(V)Ui(50/60Hz)		690	690	690	690	690	690
Rated impulse withstand voltage(kV)Uimp		6	6	6	6	6	6
Ultimate breaking capacity (kA,Icu AC 50/60Hz)	220V/240V	10	50	35	50	35	50
	380V	7.5/5	25	18	25	30	42
	415V	7.5/5	25	18	25	25	35
	440/460V	5	25	18	25	25	35
	480/500V	2.5	25	10	14	18	25
	600V	2.5	14	7.5	10	18	22
Utilisation category		A	A	A	A	A	A
Endurance	Mechanical	8500	8500	7000	7000	4000	400
	Electrical	1500	1500	1000	1000	1000	1000



M9-403S

3. Outline and Installation Dimensions (mm)

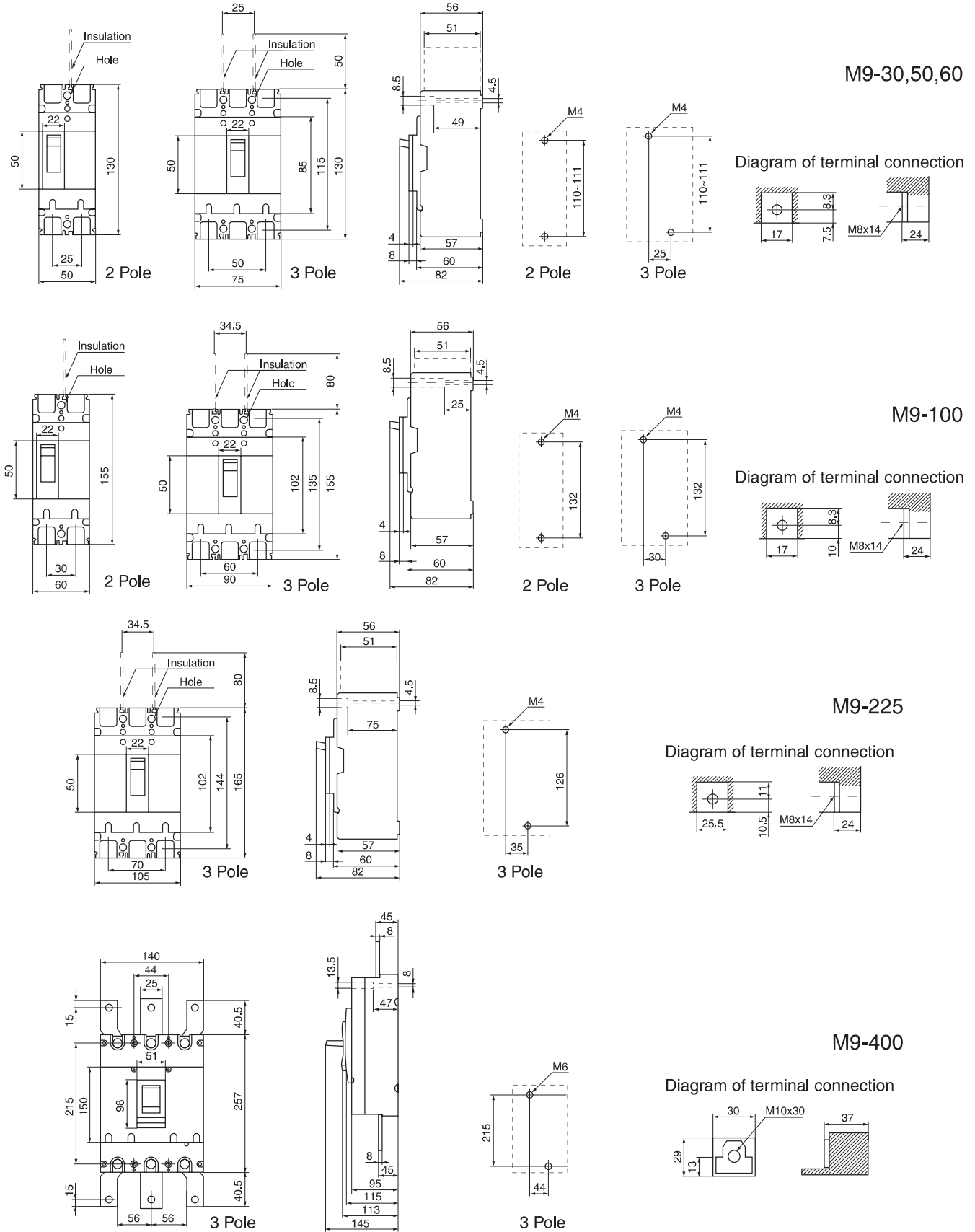

W45 Air Circuit Breaker



W45-2000

1. Application

W45 series air circuit breaker (hereinafter referred to as breaker) is suitable for the circuit of AC 50/60Hz with rated voltage 400V, 690V and rated current up to 6300A .It is mainly used to distribute electric energy and protect circuit and power supply equipment from overload, under-voltage short-circuit ,and single-phase earthing .With intelligent and selective protection functions, the breaker can improve the reliability of power supply, and avoid unnecessary power failure . The breaker is applicable for power stations, factories , mines(for 690V) and modern high-building, especially for the distribution system of intelligent building.

The breaker conforms to IEC60947-2. The whole series have past CCC certification and CE certification.

2. Working Condition

Temperature condition: $-5^{\circ}\text{C}\sim+40^{\circ}\text{C}$; the average value within 24h not exceed $+35^{\circ}\text{C}$.

Elevation: altitude of installation place shall not exceed 2000m.

Atmosphere condition: relative humidity at $+40^{\circ}\text{C}$ shall not exceed 50%. Higher humidity is permissible at lower temperature condition. When the higher monthly average relative humidity is 90% in the humiddest month , the lowest monthly average temperature of this month is $+25^{\circ}\text{C}$. And consider the influence of dew on product surface due to temperature changes.

Pollution grade: grade III.

The breaker should be installed according to the requirement on the instruction manual: the vertical inclination degree shall not exceed 5° .



W45-3200

3. Specification

Type		W45-2000	W45-3200	W45-4000	W45-6300
Frame rated current I_{nm} (A)		2000	3200	4000	6300
Number of poles		3,4	3,4	3,4	3,4
Rated current I_n (A)		630,800,1000, 1250,1600,2000	2000,2500, 3200	2000,2500, 3200,4000	4000,5000, 6300
I_{cu} (kA)	400V	80	100	100	120
	690V	50	65	65	80
$I_{cs} = I_{cw}$ (kA)	400V	50	80	80	100
	690V	40	50	50	65
Rated current at N-pole I_n (A)		50% I_n , 100% I_n			
Inherent making & breaking time		23-32ms			
Operational performance (operations)	Electric life	500			
	Mechanical life	Maintenance-free 2500 Maintenance 10000			
Mounting mode		Fixed / Withdrawable			
Arcing distance(mm)		0			
Intelligent controller		Standard type(M) telecommunication type (H)			



W45-6300

4. Intelligent Controller

Intelligent controller is one of the core components of the circuit breaker

4.1 properties of the intelligent controller

- a. Protective function of over-load long time-delay and inverse time limit, short time-delay and inverse time limit, short time-delay definite time limit instantaneous operation protection;
- b. Single-phase earthing failure protection;
- c. Display of setting current I_r and operational current;
- d. Ampere meter;
- e. Over-load alarm;
- f. Short-circuit alarm
- g. Testing of operational properties

Note: The breakers with telecommunication port are available to realize remote control to breaker through master computer.

4.2 Protection performances of over-current release

- a. I_r and its inaccuracy of the controller

$I_{nm}(A)$	Long time-delay		Short time-delay		Instantaneous		Earthing failure	
	I_{r1}	Error	I_{r2}	Error	I_{r3}	Error	I_{r4}	Error
≥ 2000	$(0.4\sim 1)I_n$	$\pm 10\%$	$(0.4\sim 15)I_n$	$\pm 10\%$	$1.0I_n\sim 15kA$	$\pm 15\%$	$I_{nm} \leq 4000A(0.2-0.8) I_n$ (Max.1200A.Min.200A)	$\pm 10\%$
							$I_{nm} \leq 6300A(0.2-1.0) I_n$	

Note: 1. When the breaker could realize over-load with long time delay ,short-circuit with short time-delay and short-circuit instantaneous protections, the setting ratings can not be over-lapped ,and $I_{r1} < I_{r2} < I_{r3}$
 2. When the frame is 3200A and above ,the setting ratings range from $1.0I_n$ to 75kA.

- b. Characteristics of long time-delay protection

1.05 I_{r1}	1.3 I_{r1}	1.5 I_r	2.0 I_{r1}
>2h non-tripping	<1h tripping	15s,30s,60s,120s,240s,480s	8.4s,16.9s,33.7s,67.5s,135s,270s

- c. Characteristics of short time-delay protection.

For low over-current ,inverse time-limit protection could be realized; when the over-current is $>8 I_{r1}$, it will automatically change to be definite time-limit protection properties.

Refer to table below for time-limit properties.

Setting delay time (s)	Returnable time (s)
0.1, 0.2, 0.3, 0.4	0.06, 0.14, 0.23, 0.35

5. Standard Composition

To facilitate your ordering and utilization, the W45 intelligent with basic electric accessories as follows.

Standard composition of the breaker	Fixed type	Withdrawable type
Body	■	■
Drawer base	■	■
Intelligent controller	■	■
Electric motor	■	■
Closing electro-magnet	■	■
Shunt release	■	■
Under-voltage	■	■
Auxiliary contact	■	■
Door frame	■	■

6. Accessories

6.1 Shunt release

a. Shunt release is for remote breaking of circuit breaker so as to enhance security of the operator;

b. Ratings of shunt release

Rated operational voltage (V)	AC220V	AC380V	DC110V	DC220V
Operational voltage range	(70%~110%) U _e			
Power consumption	24VA	24VA		40W

6.2 Under-voltage release

a. It is an optional accessory;

b. Mainly used to protect apparatus from damage due to lowering of the operational voltage to a certain value;

c. Two types of release are available: instantaneous release and time-delay release;

d. For breakers appended with the release, it should be electrified continuously;

e. Ratings of under-voltage release.

f. Operation properties of under-voltage release

Rated operational voltage (V)	AC220V	AC380V	DC110V	DC220V
Operational voltage range	(35%~110%) U _s			
Power consumption	24VA	24VA		40W

Category		Under-voltage time-delay release	Under-voltage instantaneous release
Operation time of the release		Time-delay: 1s,3s,5s	Instantaneous
Operational voltage of the release	35% U _s ~70% U _s	Break the breaker	Break the breaker
	≤ 35% U _s	Can not make the breaker	Can not make the breaker
	≥ 85% U _s ~110% U _s	Reliably make the breaker	Reliably make the breaker
Within 1/2 delay time, voltage of power supply recovers to 85% U _s		Can not trip the breaker	

Note: Error the time of time-delay is ±10%

6.3 Closing electro-magnet

a. The magnet is for remote making of circuit breaker so as to enhance security of the operator.

b. The magnet could not be electrified for a long time.

c. Ratings of the magnet.

Rated operational voltage (V)	AC220V	AC380V	DC110V	DC220V
Operational voltage range	(85%~110%) U _s			
Power consumption	40VA	40VA		40W

6.4 Auxiliary contact

a. Conventional heating current of auxiliary contact: 6A

b. Auxiliary contacts: 4NO+4NC, 3NO+NC, 5NO+5NC(customization)

7. Outline and Installation Dimensions (mm)

W45-2000 Drawer-type

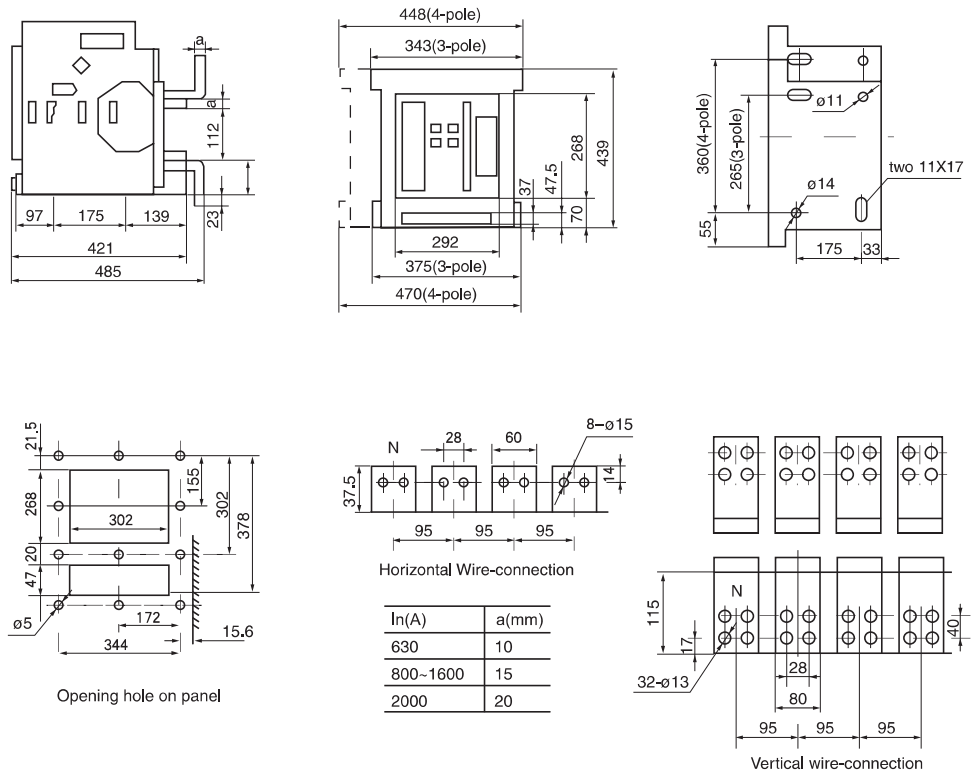

W45-2000 Fixed type

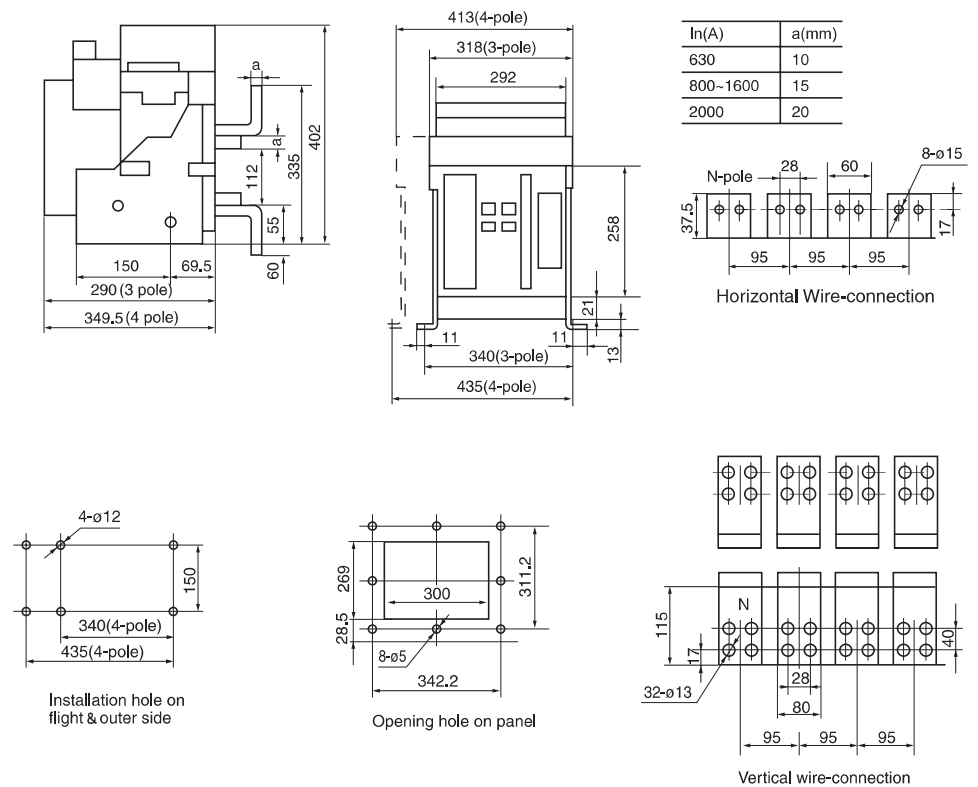

W45-3200 Drawer type

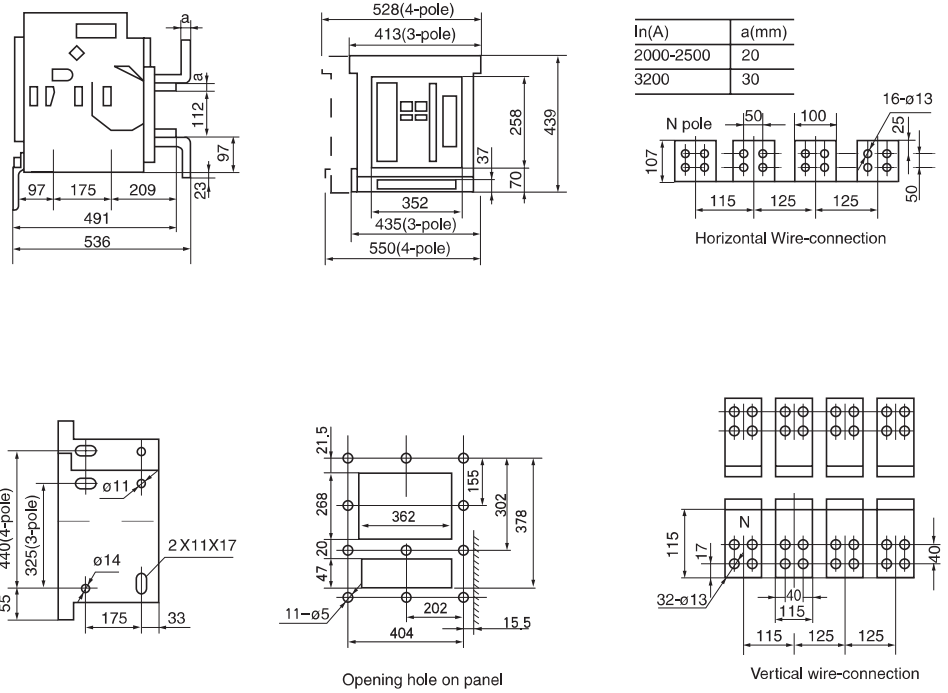

W45-3200 Fixed type

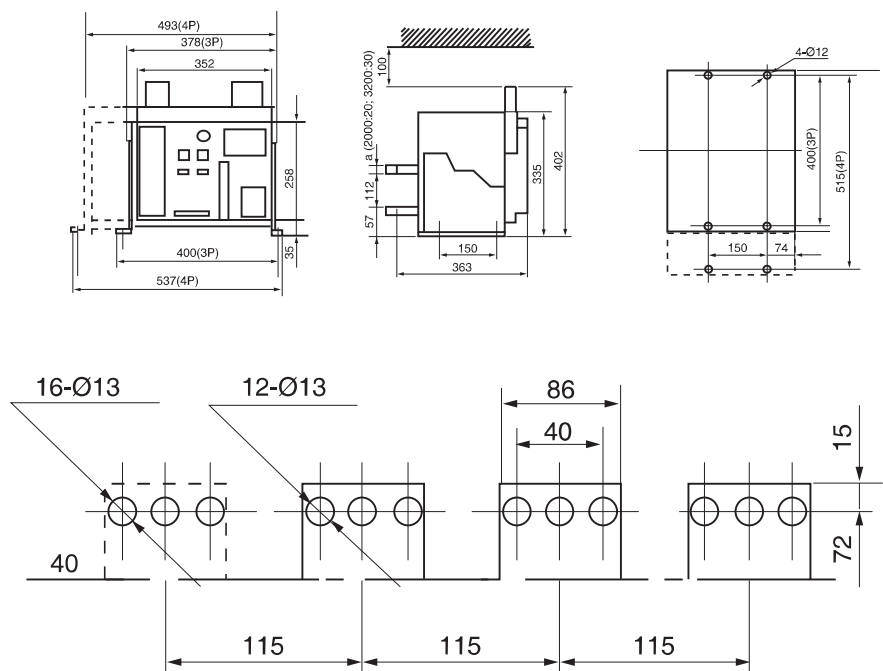

W45-4000 Drawer type (3-pole)

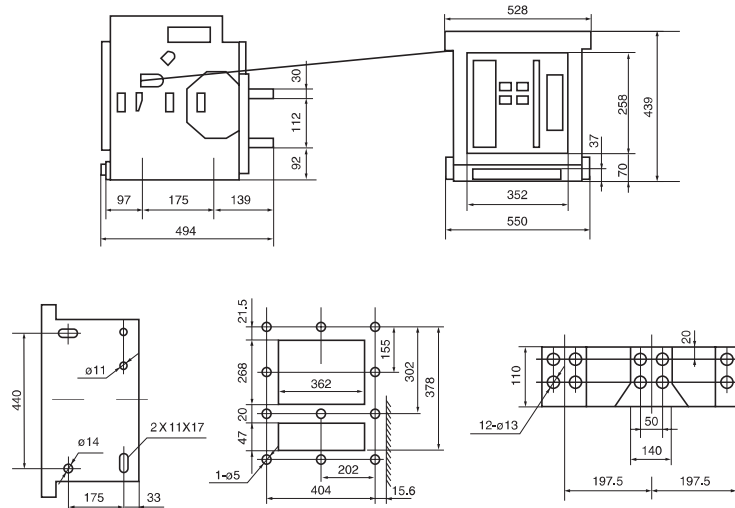

W45-4000,5000 Drawer-type

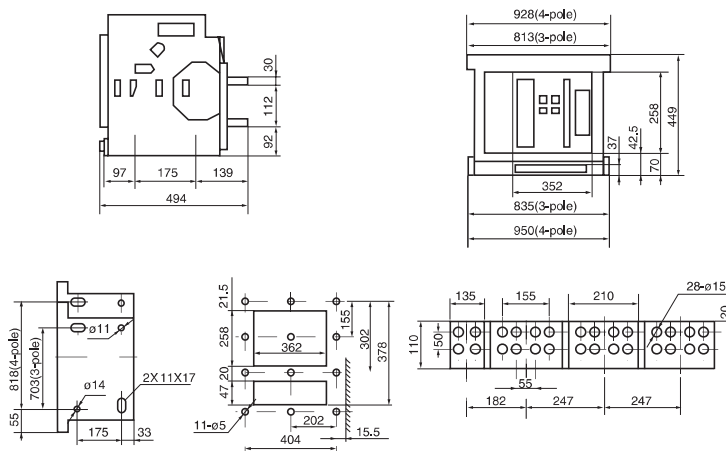

W45-6300 Drawer type (3-pole)

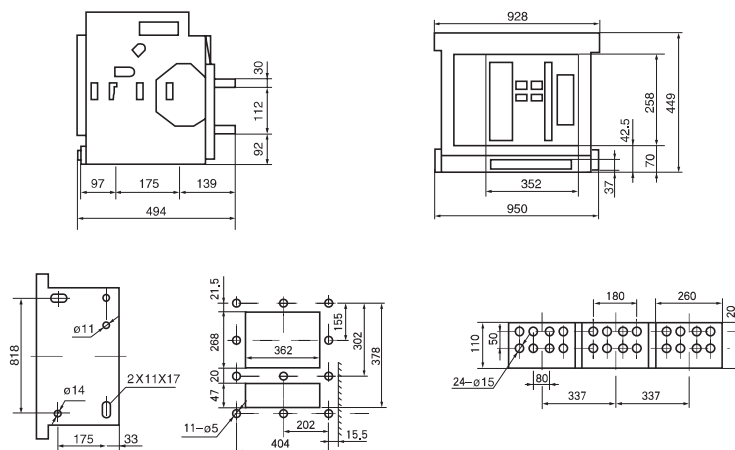

Fixed Type Structure Explosion

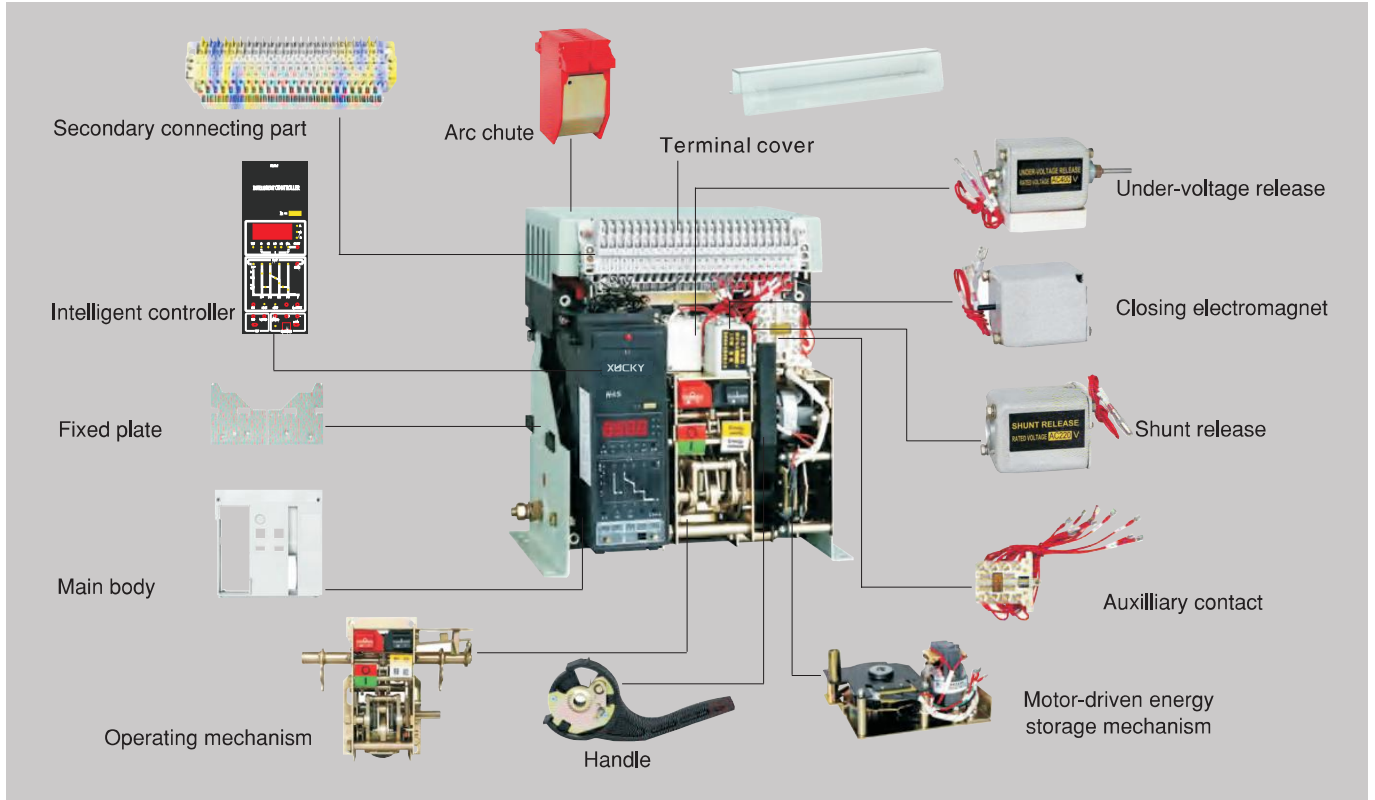

Drawer Type Structure Explosion

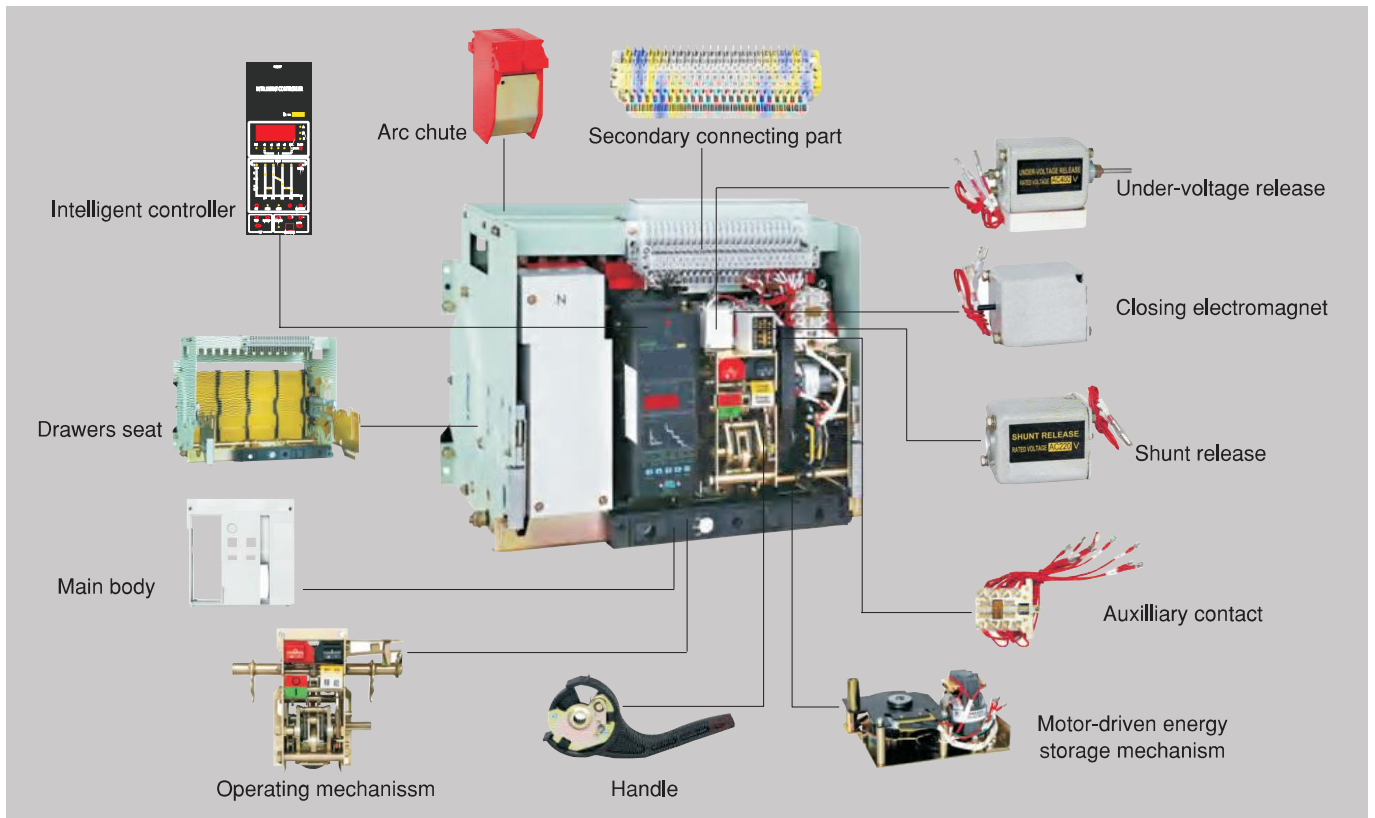

DZ30-32 Series Miniature Circuit Breaker

1. Application

DZ30-32 is used in the single phase circuit of AC 50/60Hz, rated voltage 230V or below for protecting circuit from overload and short circuit. This product has advantages of high breaking capacity, small volume, width is only 18mm. It conforms with the standards of IEC60898.



DZ30-32

2. Main Technical Parameter

Type	DZ30-32
Pole	1P+N
Rated current (A)	6,10,16,20,25,32
Rated voltage(V)	230
Type of instantaneous release	C
Rated short circuit breaking capacity Icn(A)	3000

3. Applicable Conducting Wire

Rated current(A)	Norminal cross section of wire (mm ²)
$I_n \leq 6$	1
$6 < I_n \leq 13$	1.5
$13 < I_n \leq 20$	2.5
$20 < I_n \leq 25$	4
$25 < I_n \leq 32$	6

4. The Over-current Protection Property

Ambient temperature	Initial status	Test current	Test time	Expected result	Note
30±2°C	Cold position	1.13I _n	t ≤ 1h	Non-release	—
	Carried out immediately after previous test	1.45I _n	t < 1h	Release	—
	Cold position	2.55I _n	1s < t < 60s	Release	Current smoothly rises to specified value within 5s
-5~+40°C	Cold position	5I _n	t ≥ 0.1s	Non-release	Type C
	Cold position	10I _n	t < 0.1s	Release	Type C

5. Outline & Installation Dimension(mm)

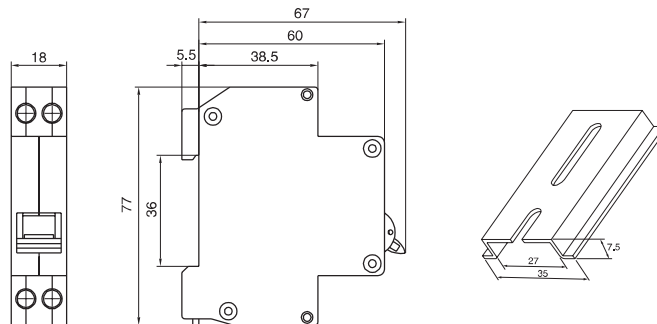

DZ47-63 Series Miniature Circuit Breaker

1. Application

DZ47-63 is applicable to a line of AC 50/60Hz, 230/400V in single pole, 400V in double, three, four poles for protecting overload and short circuit, and rated current up to 63A. It can also be used for infrequent line conversion under the normal condition. The breaker is applicable to lighting distribution system in industrial enterprise, commercially district, high-rise building and dwelling house. It conforms with the standards of IEC60898 -1.

2. Main Technical Parameter

Type	DZ47-63			
Pole	1P		2P, 3P, 4P	
Rated current (A)	6,10,16,20,25,32,40,50,63			
Rated voltage(V)	230/400		400	
Ambient temperature	-5°C~+40°C			
Type of instantaneous release	C	D	C	D
Rated short circuit breaking capacity Icn(kA)	1-32A: 6 50-63A: 4	4	1-32A: 6 50-63A: 4	4

3. Applicable Conducting Wire

Rated current(A)	Normal cross section of wire (mm ²)
1-6A	1
10A	1.5
16,20A	2.5
25A	4
32A	6
40,50A	10
63A	16

4. The Over-current Protection Property

Ambient temperature	Initial status	Test current	Test time	Expected result	Note
30±2°C	Cold position	1.13In	t ≤ 1h	Non-release	—
	Carried out immediately after previous test	1.45In	t < 1h	Release	—
	Cold position	2.55In	1s < t < 60s (In ≤ 32A)	Release	Current smoothly rises to specified value within 5s
	Cold position	2.55In	1s < t < 120s (In > 32A)	Release	
-5~+40°C	Cold position	3In	t ≤ 0.1s	Non-release	Type B
	Cold position	5In	t < 0.1s	Release	Type B
	Cold position	5In	t ≥ 0.1s	Non-release	Type C
	Cold position	10In	t < 0.1s	Release	Type C
	Cold position	10In	t ≥ 0.1s	Non-release	Type D
	Cold position	20In	t < 0.1s	Release	Type D

5. Outline and Installation Dimensions (mm)

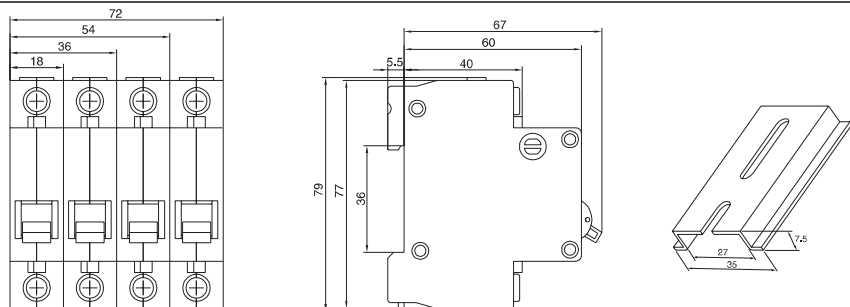

DZ47-63 1P



DZ47-63 2P



DZ47-63 3P



DZ47-63 4P

DZ47-63H Series Miniature Circuit Breaker



DZ47-63H 1P



DZ47-63H 2P



DZ47-63H 3P



DZ47-63H 4P

1. Application

DZ47-63H is applicable to a line of AC 50/60Hz, 230/400V in single pole, 400V in double, three, four poles for protecting overload and short circuit, and rated current up to 63A. It can also be used for infrequent line conversion under the normal condition. The breaker is applicable to lighting distribution system in industrial enterprise, commercially district, high-rise building and dwelling house. It conforms with the standards of IEC60898 -1.

2. Main Technical Parameter

Type	DZ47-63H 1P			
Pole	1P		2P, 3P, 4P	
Rated current (A)	6, 10, 16, 20, 25, 32, 40, 50, 63			
Rated voltage(V)	230/400		400	
Ambient temperature	-5°C~+40°C			
Type of instantaneous release	C	D	C	D
Rated short circuit breaking capacity Icn(kA)	1-32A: 6 50-63A: 4	6	1-32A: 6 50-63A: 4	6

3. Applicable Conducting Wire

Rated current(A)	Normal cross section of wire (mm ²)
1-6A	1
10A	1.5
16,20A	2.5
25A	4
32A	6
40,50A	10
63A	16

4. The Over-current Protection Property

Ambient temperature	Initial status	Test current	Test time	Expected result	Note
30±2°C	Cold position	1.13In	t ≤ 1h	Non-release	—
	Carried out immediately after previous test	1.45In	t<1h	Release	—
	Cold position	2.55In	1s<t<60s (In ≤ 32A)	Release	Current smoothly rises to specified value within 5s
	Cold position	2.55In	1s<t<120s (In>32A)	Release	
-5~+40°C	Cold position	3In	t ≤ 0.1s	Non-release	Type B
	Cold position	5In	t<0.1s	Release	Type B
	Cold position	5In	t ≥ 0.1s	Non-release	Type C
	Cold position	10In	t<0.1s	Release	Type C
	Cold position	10In	t ≥ 0.1s	Non-release	Type D
	Cold position	20In	t<0.1s	Release	Type D

5. Outline and Installation Dimensions (mm)

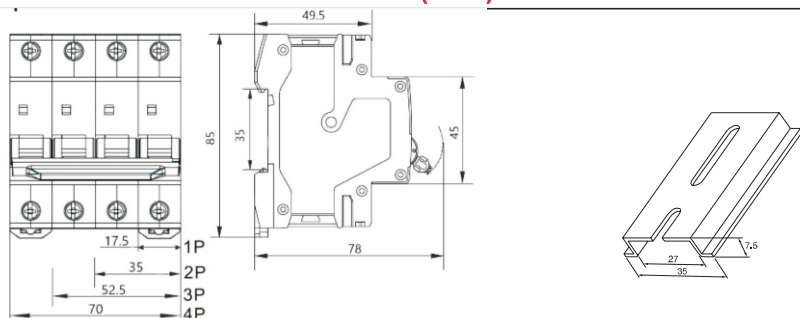

DZ47N-63 Series Miniature Circuit Breaker

1. Application

DZ47N-63 is applicable to a line of AC 50/60Hz 230/400V in single pole, 400V in double, three, four poles for protecting overload and short circuit, and rated current up to 63A. It can also be used for infrequent line conversion under the normal condition. The breaker is applicable to lighting distribution system in industrial enterprise, commercially district, high-rise building and dwelling house. It conforms with the standards of IEC60898-1.



DZ47N-63 1P



DZ47N-63 2P



DZ47N-63 3P



DZ47N-63 4P

2. Main Technical Parameter

Type	DZ47N-63			
Pole	1P		2P, 3P, 4P	
Rated current (A)	6,10,16,20,25,32,40,50,63			
Rated voltage(V)	230/400		400	
Ambient temperature	-5°C~+40°C			
Type of instantaneous release	C	D	C	D
Rated short circuit breaking capacity Icn(kA)	1-32A: 6 50-63A: 4	4	1-32A: 6 50-63A: 4	4

3. Applicable Conducting Wire

Rated current(A)	Normal cross section of wire (mm ²)
1-6A	1
10A	1.5
16,20A	2.5
25A	4
32A	6
40,50A	10
63A	16

4. The Over-current Protection Property

Ambient temperature	Initial status	Test current	Test time	Expected result	Note
30±2°C	Cold position	1.13In	t ≤ 1h	Non-release	—
	Carried out immediately after previous test	1.45In	t < 1h	Release	—
	Cold position	2.55In	1s < t < 60s (In ≤ 32A)	Release	Current smoothly rises to specified value within 5s
	Cold position	2.55In	1s < t < 120s (In > 32A)	Release	
-5~+40°C	Cold position	3In	t ≤ 0.1s	Non-release	Type B
	Cold position	5In	t < 0.1s	Release	Type B
	Cold position	5In	t ≥ 0.1s	Non-release	Type C
	Cold position	10In	t < 0.1s	Release	Type C
	Cold position	10In	t ≥ 0.1s	Non-release	Type D
	Cold position	20In	t < 0.1s	Release	Type D

5. Outline & Installation Dimension(mm)

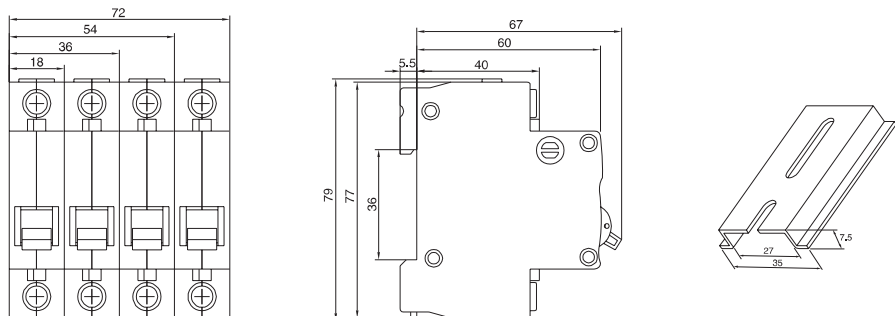

DZ47-100 Series Miniature Circuit Breaker

1. Application

DZ47-100 is such features as delicate appearance, light weight, excellent and reliable performance, high breaking capacity, rapid tripping and mounted by rail. Its enclosure and components adopts high fire-retarding and shock-resistance plastic of long durability. It mainly serves for protecting the circuits of AC 50/60Hz, 230V of single pole, 400V of two poles or three or four poles from overload or short-circuit, and also for unfrequent making and breaking electrical apparatus and lighting circuit. It conforms with the standards of IEC60947-2.



DZ47-100 1P



DZ47-100 2P



DZ47-100 3P



DZ47-100 4P

2. Main Technical Parameter

Type	DZ47-100	
Pole	1P	2P, 3P, 4P
Rated current (A)	63,80,100	
Rated voltage (V)	230	400
Ambient temperature	-5°C~+40°C	
Type of instantaneous release	C, D	
Rated short circuit breaking capacity Icn(kA)	6	

3. The Over-current Protection Property

Ambient temperature	Initial status	Test current	Test time	Expected result	Note
40±2°C	Cold position	1.05In (In ≤ 63A)	t ≤ 1h	Non-release	—
	Cold position	1.05In (In > 63A)	t ≤ 2h	Non-release	—
	Carried out immediately after previous test	1.30In (In ≤ 63A)	t < 1h	Release	Current smoothly rises to specified value within 5s
	1.30In (In > 63A)	t < 2h	Release		
-5~+40°C	Cold position	8.00In	t ≤ 0.2s	Non-release	—
	Cold position	12.00In	t < 0.2s	Non-release	—

4. Applicable Conducting Wire

Rated current(A)	Nominal cross section of wire (mm ²)
63A	16
80A	25
100A	35

5. Outline & Installation Dimension(mm)

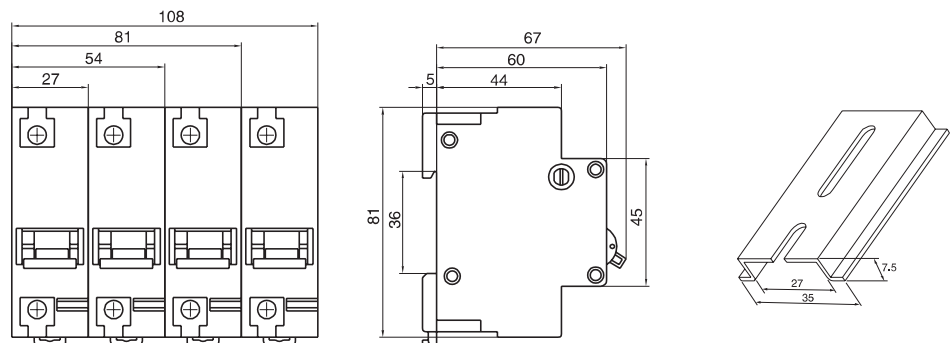



DZ48N-63 1P

DZ48N-63 Series Miniature Circuit Breaker

1. Application

DZ48N-63 miniature circuit breaker is applicable to a line of AC 50/60Hz, 230V in single pole, 400V in double, three, four poles for protecting overload and short circuit, and rated current up to 63A. It can also be used for infrequent line conversion under the normal condition. The breaker is applicable to lighting distribution system in industrial enterprise, commercially district, high-rise building and dwelling house. It conforms with the standards of IEC60947-2.

2. Main Technical Parameter

Type		DZ48N-63			
Pole		1P		2P, 3P, 4P	
Rated current (A)		6,10,16,20,25,32,40,50,63			
Rated voltage(V)		230		400	
Type of instantaneous release		C	D	C	D
Rated short circuit breaking capacity Icn(kA)		1-40A: 6 50-63A: 4.5	4.5	1-40A: 6 50-63A: 4.5	4.5
Life (times)	1-32A	Electric life	4000		
		Mechanical life	6000		
		Operation frequency	240 times per hour		
	40-63A	Electric life	4000		
		Mechanical life	6000		
		Operation frequency	120 times per hour		

3. Applicable Conducting Wire

Rated current(A)	Nominal cross section of wire (mm ²)
1-6A	1
10A	1.5
16,20A	2.5
25A	4
32A	6
40,50A	10
63A	16

4. The Over-current Protection Property

Ambient temperature	Initial status	Test current	Test time	Expected result	Note
30±2°C	Cold position	1.13In	t ≤ 1h	Non-release	—
	Carried out immediately after previous test	1.45In	t < 1h	Release	—
	Cold position	2.55In	1s < t < 60s (In ≤ 32A)	Release	Current smoothly rises to specified value within 5s
	Cold position	2.55In	1s < t < 120s (In > 32A)	Release	
-5~+40°C	Cold position	3In	t ≤ 0.1s	Non-release	Type B
	Cold position	5In	t < 0.1s	Release	Type B
	Cold position	5In	t ≥ 0.1s	Non-release	Type C
	Cold position	10In	t < 0.1s	Release	Type C
	Cold position	10In	t ≥ 0.1s	Non-release	Type D
	Cold position	20In	t < 0.1s	Release	Type D

5. Outline & Installation Dimension(mm)

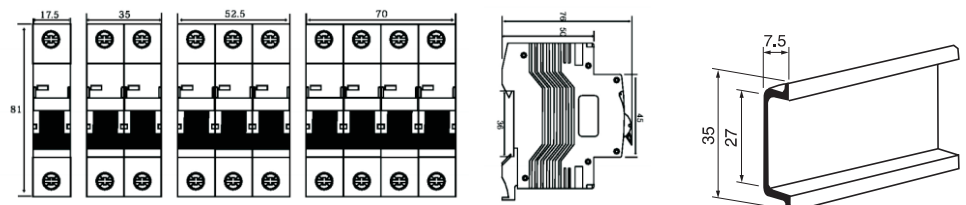

DZ49-63 Series Miniature Circuit Breaker

1. Application

DZ49-63 is applicable to a line of AC 50/60Hz, 230V in single pole, 400V in double, three, four poles for protecting overload and short circuit, and rated current up to 63A. It can also be used for infrequent line conversion under the normal condition. The breaker is applicable to lighting distribution system in industrial enterprise, commercially district, high-rise building and dwelling house. It conforms with the standards of IEC60947-2.



DZ49-63 1P



DZ49-63 2P



DZ49-63 3P



DZ49-63 4P

2. Main Technical Parameter

Type	DZ49-63			
Pole	1P	2P, 3P, 4P		
Rated current (A)	6, 10, 16, 20, 25, 32, 40, 50, 63			
Rated voltage(V)	230	400		
Ambient temperature	-5°C~+40°C			
Type of instantaneous release	C	D	C	D
Rated short circuit breaking capacity(kA)	1-32A: 6 50-63A: 4	4.5	1-32A: 6 50-63A: 4	4.5

3. Applicable Conducting Wire

Rated current(A)	Nominal cross section of wire (mm ²)
1-6A	1
10A	1.5
16,20A	2.5
25A	4
32A	6
40,50A	10
63A	16

4. The Over-current Protection Property

Ambient temperature	Initial status	Test current	Test time	Expected result	Note
30±2°C	Cold position	1.13In	t ≤ 1h	Non-release	—
	Carried out immediately after previous test	1.45In	t < 1h	Release	—
	Cold position	2.55In	1s < t < 60s (In ≤ 32A)	Release	Current smoothly rises to specified value within 5s
	Cold position	2.55In	1s < t < 120s (In > 32A)	Release	
-5~+40°C	Cold position	3In	t ≤ 0.1s	Non-release	Type B
	Cold position	5In	t < 0.1s	Release	Type B
	Cold position	5In	t ≥ 0.1s	Non-release	Type C
	Cold position	10In	t < 0.1s	Release	Type C
	Cold position	10In	t ≥ 0.1s	Non-release	Type D
	Cold position	20In	t < 0.1s	Release	Type D

5. Outline & Installation Dimension(mm)

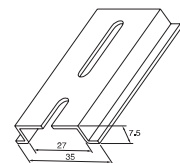
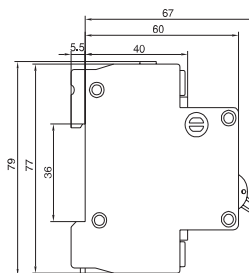
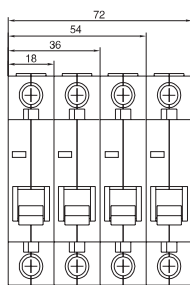

DZ50-63 Series Miniature Circuit Breaker

1. Application

DZ50-63 high switch-off ability miniature circuit breaker is applicable to a line of AC 50/60Hz, rated voltage 230/400V and rated current up to 63A, used for overload and short circuit protection. It can also be used for infrequent line conversion under the normal condition. The breaker is applicable to industrial enterprise, commercially district, high-rise building and dwelling house. It conforms with the standards of IEC60947-2.



DZ50-63 1P



DZ50-63 2P



DZ50-63 3P



DZ50-63 4P

2. Main Technical Parameter

Type		DZ50-63	
Pole		1P	2P, 3P, 4P
Rated current (A)		1,2,3,4,6,10,16,20,25,32,40,50,63	
Rated voltage(V)		230	400
Type of instantaneous release		B,C,D	
Rated short circuit breaking capacity Icn(kA)		10	
Life (times)	1-32A	Electric life	8000
		Mechanical life	20000
		Operation frequency	240 times per hour
	40-63A	Electric life	8000
		Mechanical life	20000
		Operation frequency	120 times per hour

3. Applicable Conducting Wire

Rated current(A)	Nominal cross section of wire (mm ²)
1-6A	1
10A	1.5
16,20A	2.5
25A	4
32A	6
40,50A	10
63A	16

4. The Over-current Protection Property

Ambient temperature	Initial status	Test current	Test time	Expected result	Note
30±2°C	Cold position	1.13In	t ≤ 1h	Non-release	—
	Carried out immediately after previous test	1.45In	t < 1h	Release	—
	Cold position	2.55In	1s < t < 60s (In ≤ 32A)	Release	Current smoothly rises to specified value within 5s
	Cold position	2.55In	1s < t < 120s (In > 32A)	Release	
-5~+40°C	Cold position	3In	t ≤ 0.1s	Non-release	Type B
	Cold position	5In	t < 0.1s	Release	Type B
	Cold position	5In	t ≥ 0.1s	Non-release	Type C
	Cold position	10In	t < 0.1s	Release	Type C
	Cold position	10In	t ≥ 0.1s	Non-release	Type D
	Cold position	20In	t < 0.1s	Release	Type D

5. Outline & Installation Dimension(mm)

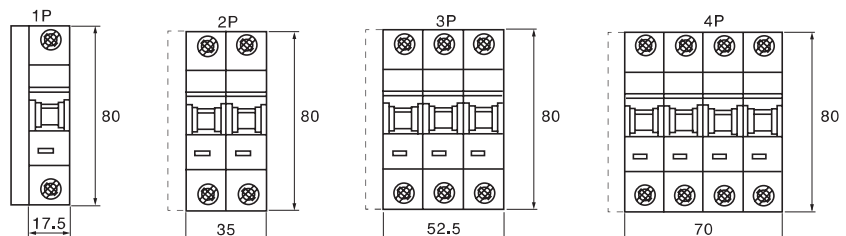

DZ50N-63 Series Miniature Circuit Breaker

1. Application

DZ50N-63 high breaking capacity miniature circuit breaker is applicable to a line of AC50 / 60Hz, rated voltage 23/400V and rated current up to 63A, used for overload and short circuit protection. It can also be used for infrequent line conversion under the normal condition. The breaker is applicable to industrial enterprise, commercially district, high-rise building and dwelling house. It conforms with the standards of IEC60947-2.

2. Main Technical Parameter

Type		DZ50-63	
Pole		1P	2P, 3P, 4P
Rated current (A)		1,2,3,4,6,10,16,20,25,32,40,50,63	
Rated voltage(V)		230	400
Type of instantaneous release		B,C,D	
Rated short circuit breaking capacity Icn (kA)		10	
Life (times)	1-32A	Electric life	8000
		Mechanic life	20000
		Operation frequency	240 times per hour
	40-63A	Electric life	8000
		Mechanic life	20000
		Operation frequency	120 times per hour

3. Applicable Conducting Wire

Rated current(A)	Nominal cross section of wire (mm ²)
1-6A	1
10A	1.5
16,20A	2.5
25A	4
32A	6
40,50A	10
63A	16

4. The Over-current Protection Property

Ambient temperature	Initial status	Test current	Test time	Expected result	Note
30±2°C	Cold position	1.13In	t ≤ 1h	Non-release	-
	Carried out immediately after previous test	1.45In	t < 1h	Release	-
	Cold position	2.55In	1s < t < 60s (In ≤ 32A)	Release	Current smoothly rises to specified value within 5s
	Cold position	2.55In	1s < t < 120s (In > 32A)	Release	
-5~+40°C	Cold position	3In	t ≤ 0.1s	Non-release	Type B
	Cold position	5In	t < 0.1s	Release	Type B
	Cold position	5In	t ≥ 0.1s	Non-release	Type C
	Cold position	10In	t < 0.1s	Release	Type C
	Cold position	10In	t ≥ 0.1s	Non-release	Type D
	Cold position	20In	t < 0.1s	Release	Type D

5. Outline & Installation Dimension(mm)

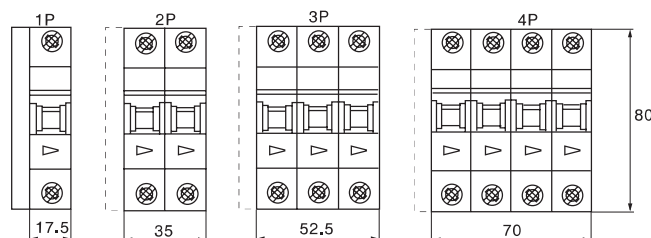

DZ50N-63 1P



DZ50N-63 2P



DZ50N-63 3P



DZ50N-63 4P

DZ7S-100ZFD Series Automatic Reset Circuit Breaker



DZ7S-100ZFD 2P

1.Application

DZ7S-100ZFD series automatic reset circuit breaker is used for electricity consumption information collect and management system of power grid company, it is applicable to a line of AC50/60Hz, rated working voltage of 230/400V and rated control voltage of 220V, rated current up to 100A, it's rated isolating voltage is 500V. It conforms with the standard of IEC60898-1.

2.Type Meaning

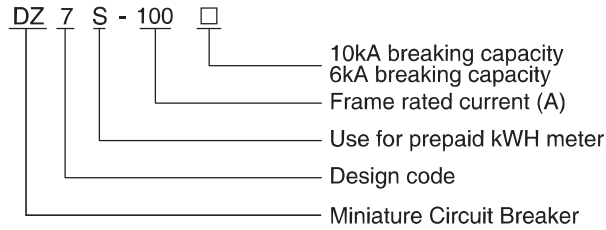

3.Product Features

- Ultra-small volume: the control part use single module design,width is only 18mm.
- Powerful function: open and close automatically according to the situation of prepaid electricity charge. It can trip fastly,and keep the trip status when electricity charge is run out.
- Fast action: close within 3 seconds and open within 2 seconds.
- Reliable performance: mechanical life more than 20,000 operation cycles.
- High safety: breaking capacity up to 10kA.With open safety lock hole.
- Reliable transmission: use inside axis for transmission to ensure the 2 poles and 4 poles breaker can close synchronously.
- Good compatibility: conform the standard of module terminal combined electric equipment,installed on DIN rail and easy for exchange.
- Environmentally friendly: low power consumption,use environmental protection materials and conform to RoHS requirements.
- Strong adaptability: suitable use at temperature of -40°C~70°C.



DZ7S-100ZFD 4P

4.Main Technical Parameter

Type	DZ7S-100ZFD	
	2P	4P
Frame rated current $I_{nm}(A)$	80	80
Rated current $I_n(A)$	40,50,63,80	
Rated isolate voltage $U_i(V)$	500	
Rated working voltage $U_e(V)$	230	400
Rated impulse withstanding voltage (kV)	6	
Rated breaking capacity $I_{cn}(kA)$	10	
Rated working breaking capacity $I_{cs}(kA)$	7.5	
Rated frequency $F_n(Hz)$	50/60	
Curve type	C	
Working life	Mechanical life	20000
	Electrical life	8000
Working environment (°C)	Normal working temperature:-25~65; limit working temperature:-40~70	

5.Outline Dimension (mm)

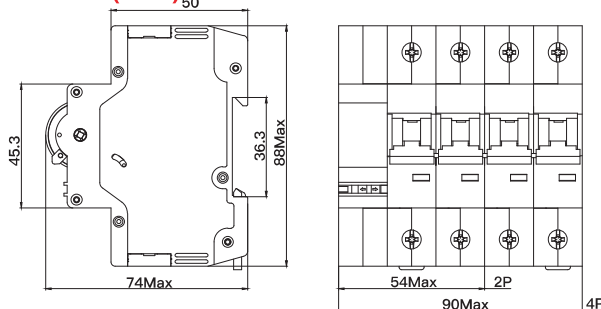

Electrical Accessories of Miniature Circuit Breaker



AOF-1

Accessory Name	Cat No.
Auxiliary contact	DZ58OF
Alarm contact	DZ58SD
Shunt release, used for 24~48V	DZ58MX24
Shunt release+Alarm contact,used for 24~48V	DZ58MS24
Shunt release+Auxiliary contact,used for 24~48V	DZ58MO24
Shunt release,used for 110~415V	DZ58MX220
Shunt release+Alarm contact,used for 110~415V	DZ58MS220
Shunt release+Alarm contact,used for 110~415V	DZ58MO220

Note: The auxiliary contact and alarm contact are optional for DZ47LE
All of accessories are optional for DZ58

AOF-1 Auxiliary Contact

Rated operating voltage Ue V	AC230	AC400	DC24	DC48	DC110	DC220
Rated operating current Ie A	6	3	6	2	1	0.4
The mode of auxiliary contact	NO NC					
Connection diagram						



ABL-1

ABL-1 Alarm Contact

Rated operating voltage Ue V	AC230	AC400	DC24	DC48	DC110	DC220
Rated operating current Ie A	6	3	6	2	1	0.4
The mode of auxiliary contact	NO NC					
Connection diagram						

Outline & Installation Dimension(mm)





AOUT-1

AST-1 Shunt Release

Control voltage Ue V	AC230, DC24
Operating voltage V	When the power voltage is equal to 70%~110% of the rated control power voltage (us) the shunt release should be released at any operation condition of the breaker.
Connection diagram	

AOUT-1 Over-Voltage & Under-Voltage Release

Rated control power voltage Ue V	AC: 48, 230
Under-voltage operating voltage V	The release can be released reliably when the voltage is 35%~70% of the rated working voltage; it should ensure switch-on when the voltage is 85%~100% of the rated working voltage and should prevent switch-on when the voltage is lower than 35% of the rated working voltage
Over-voltage operating voltage V	280V ±5%
Connection diagram	

Outline & Installation Dimension(mm)



DZ47LE-63 Residual Current Operated Circuit Breaker With Over-current Protection

1. Application

DZ47LE-63 is applicable to a line of AC 50/60Hz, rated voltage 230V for single pole two-wire, 2-pole or 400V for 3-pole, 3-pole 4-wire, 4-pole and rated current up to 63A. It can protect the line and motor from overload and short circuit. It can also be used for infrequent line conversion and infrequent motor start. It conforms with the standards of IEC60947-2.

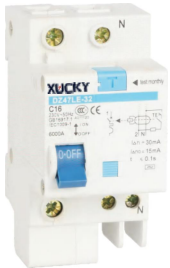

DZ47LE-63 1P+N



DZ47LE-63 2P



DZ47LE-63 3P



DZ47LE-63 4P

2. Main Technical Parameter

Type	DZ47LE-63	
Pole	1P+N, 2P	3P, 3P+N, 4P
Rated current (A)	6, 10, 16, 20, 25, 32, 40, 50, 63	
Rated voltage (V)	230	400
Rated short circuit breaking capacity I _{cn} (kA)	6-32A:6 / 40-63A:4.5	
Rated residual making/breaking capacity I _{Δm} (A)	2000	
Rated residual action current I _{Δn} (A)	0.03, 0.05, 0.1, 0.3	
Rated residual non-action current I _{Δno} (A)	0.5I _{Δn}	

3. Applicable Conducting Wire

Rated current(A)	1-6A	10A	16,20A	25A	32A	40,50A	63A
Norminal cross section of wire mm ²	1	1.5	2.5	4	6	10	16

4. Residual Current Breaking Time

I _n (A)	I _{Δn} (A)	Breaking time(s) when equals to rating following				
		I _{Δn}	2I _{Δn}	5I _{Δn}	5, 10, 20, 50, 100, 200, 500 ^a (A)	I _{Δt} ^b
6-63	0.03, 0.05, 0.1, 0.3	0.1	0.06	0.04	0.04	0.04

5. The Over-current Protection Property

Ambient temperature	Initial status	Test current	Test time	Expected result	Note
30±2°C	Cold position	1.13I _n	t ≤ 1h	Non-release	-
	Carried out immediately after previous test	1.45I _n	t < 1h	Release	-
	Cold position	2.55I _n	1s < t < 60s (I _n ≤ 32A)	Release	Current smoothly rises to specified value within 5s
	Cold position	2.55I _n	1s < t < 120s (I _n > 32A)	Release	
-5~+40°C	Cold position	3I _n	t ≤ 0.1s	Non-release	Type B
	Cold position	5I _n	t < 0.1s	Release	Type B
	Cold position	5I _n	t ≥ 0.1s	Non-release	Type C
	Cold position	10I _n	t < 0.1s	Release	Type C
	Cold position	10I _n	t ≥ 0.1s	Non-release	Type D
	Cold position	20I _n	t < 0.1s	Release	Type D

6. Outline & Installation Dimension(mm)

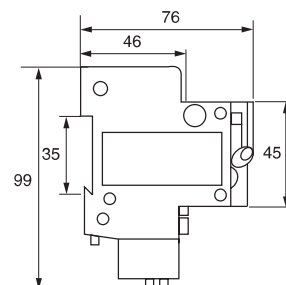
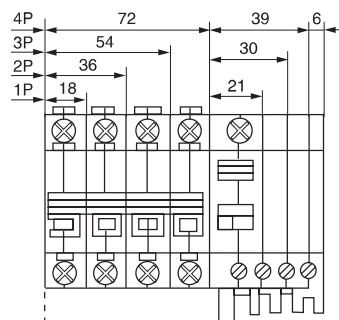

4P:72+45
3P+N:54+36
3P:54+36
2P:36+27
1P:18+27



DZL3 2P



DZL3 4P

DZL3 Residual Current Circuit Breaker

1. Application

DZL3 residual current circuit breaker is in conformity with the standards of IEC61008. It can cut off the fault circuit immediately on the occasion of shock hazard or earth leakage of trunk line. Thus it is suitable to avoid the shock hazard and fire caused by earth leakage. It can be used in circuits up to single phase 240V, three phases 415V, 50/60Hz.

2. Construction Features

- 2.1 Measuring component and buckling component of products is located between enter line end and entrance line end;
- 2.2 Movement characteristic of products can not be changed with outside mechanical tool;
- 2.3 The operating organization has the free function to take off and buckle;
- 2.4 Operate part can not be taken down from the shell outer of products, the shell can not influence the operating organization to work, the accessory group which replace the feelers pressure, should guarantee the feelers pressure does not change while running.

3. Normal Operation And Mounting Requirement

- Circumstance temperature $-5^{\circ}\text{C} \sim +40^{\circ}\text{C}$, average temperature within 24h not exceeding $+35^{\circ}\text{C}$.
- Altitude above sea level less than 2000 m.
- Humidity not exceeding 50% at 40°C and not exceeding 90% at 25°C .
- Installation class II or III.
- Pollution class 2.
- Installation method DIN Rail mounting type.
- The external magnetism shall not be more than 5 times of terrestrial one.
- Product shall be installed at the place where there shall be no severe impact and vibration.
- Product shall be vertically mounted onto standard Din rail 35mm.

4. Main Technical Parameter

Type	DZL3	
	2P	4P
Pole		
Rated current $I_n(\text{A})$	10, 16, 25, 32, 40, 63	10, 16, 25, 32, 40, 63
Rated residual operating current $I_{\Delta n}(\text{mA})$	10, 30, 100, 300	30, 100, 300
Rated residual non-operating current $I_{\Delta no}(\text{mA})$	0.5 $I_{\Delta n}$	
Rated voltage $U_n(\text{V})$	240(220), 415(380)	
Tripping time	<0.1s	
Ambient temperature	$-5^{\circ}\text{C} \sim +40^{\circ}\text{C}$	
Vibration resistance	Minimum 5g 30min, 0~8Hz	

5. Outline and Mounting Dimension (mm)

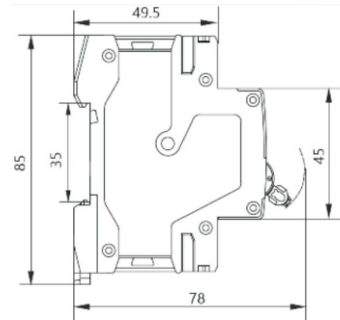
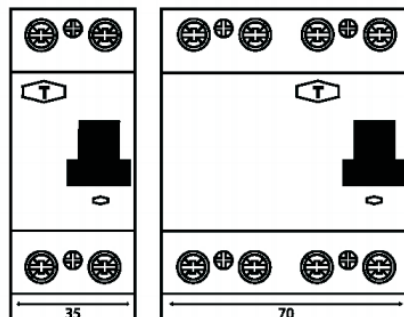

DZL7 Residual Current Circuit Breaker



DZL7 2P



DZL7 4P



DZL7N 2P

1. Application

DZL7 residual current device is in conformity with the standards of IEC61008. It can cut off the fault circuit immediately on the occasion of shock hazard or earth leakage of trunk line. Thus it is suitable to avoid the shock hazard and fire caused by earth leakage. It can be used in circuits up to single phase 240V, three phase 415V, 50/60Hz.

2. Main Technical Parameter

Type	DZL7
Pole	2P, 4P
Rated current I_n (A)	25,40,63
Rated residual operating current ($I_{\Delta n}$ A)	10,30,100,300,500
Rated non-operating current for earth leakage $I_{\Delta n}$ (A)	$0.5I_{\Delta n}$
Rated voltage U_n (V)	240(220) 415(380)
Residual current off-time:	<0.1s
Minimum value of rated making and breaking capacity	1kA
Rated conditional short-circuit current (I_{nc})	$I_n=25,40A$ $I_{nc}=1500A$ $I_n=63A$ $I_{nc}=3000A$

3. Outline and Mounting Dimension (mm)

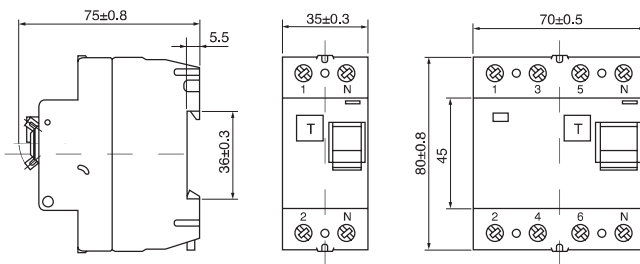

DZL7N Residual Current Circuit Breaker

1. Application

DZL7N residual current device is in conformity with the standards of IEC61008. It can cut off the fault circuit immediately on the occasion of shock hazard or earth leakage of trunk line. Thus it is suitable to avoid the shock hazard and fire caused by earth leakage. It can be used in circuits up to single phase 240V, threephase 415V, 50/60Hz.

2. Main Technical Parameter

Type	DZL7N
Pole	2P
Rated current I_n (A)	25,40
Rated residual operating current ($I_{\Delta n}$ A)	10,30,100,300,500
Rated non-operating current for earth leakage $I_{\Delta n}$ (A)	$0.5I_{\Delta n}$
Rated voltage U_n (V)	240(220) 415(380)
Residual current off-time:	<0.1s
Minimum value of rated making and breaking capacity	1kA
Rated conditional short-circuit current (I_{nc})	$I_n=25,40A$ $I_{nc}=1500A$ $I_n=63A$ $I_{nc}=3000A$

3. Outline and Mounting Dimension (mm)

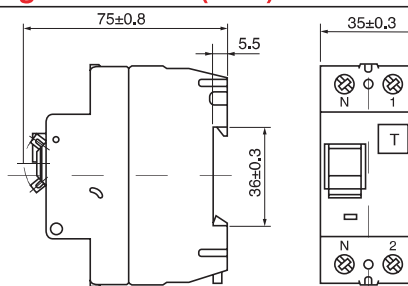

DZL4 Residual Current Circuit Breaker

1. Application

DZL4 RCCB is in conformity with the standard of IEC61008. The RCCB can cut off the fault circuit immediately on the occasion of shock hazard or earth leakage of trunk. Thus, it is suitable to avoid the shock hazard and fire caused by earth leakage.

The RCCB is mainly suitable for use in varieties of plants and enterprises, building construction 1 phase 230V and 3 phase 400V 50/60Hz. RCCB is not suitable for use on DC pulse system.

2. Specification

Number of Poles	2P, 4P
Rated current (A)	16, 20, 25, 40, 50, 63
Rated residual operating current (I Δ n)(mA)	30, 100, 300, 500
Rated voltage (V)	AC 230/240
	AC 400/415
Residual operating current scope	0.5I Δ n~I Δ n
Residual current off-time	≤ 0.3S
Rated breaking capacity (Icu)	6000A
Endurance(times)	4000
Protection degree	IP20

3. Outline and Mounting Dimension (mm)

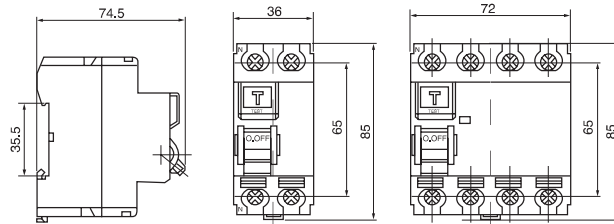

DZL4 2P



DZL4 4P

DZL5 Residual Current Circuit Breaker

1. Application

DZL5 residual current breaker is used in circuits up to single phase 230V, three phase 400V 50/60 Hz. RCCB is not suitable for use on DC pulse system. The RCCB can cut off the fault circuit immediately on the occasion of shock hazard or earth leakage of trunk. Thus it is suitable to avoid the shock hazard and fire caused by earth leakage. The RCCB is mainly suitable for use in variety of plants and enterprises, building construction, commerce, guesthouses and families. It conforms with the standards of IEC61008.

2. Main Technical Parameter

Type	DZL5
Pole	2P, 4P
Rated current I n (A)	25,40,63
Rated residual operating current (I Δ nA)	10,30,100,300,500
Rated non-operating current for earth leakage I Δ n(A)	0.5I Δ n
Rated voltage U n (V)	240(220) 415(380)
Residual current off-time:	<0.1s
Minimum value of rated making and breaking capacity	1kA
Rated conditional short-circuit current (I nc)	I n =25,40A I nc =1500A I n =63A I nc =3000A

3. Outline and Mounting Dimension (mm)

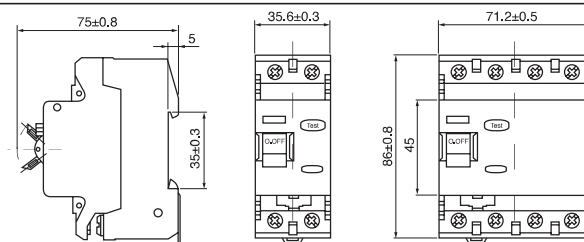

DZL5 2P



DZL5 4P

PG Residual Current Circuit Breaker

1. Application

PG is adjustable from 10A up to 60A. It can protect against overload and short circuit. The products comply with IEC61008.

2. Specification

Type	Poles	Rated voltage	Leakage operating current(A)	Leakage non-operating current (A)
PG215 5-15A	2P	230/400V	300mA 500mA	150mA 250mA
PG230 10-30A				
PG260 30-60A				
PG415 5-15A	4P			
PG430 10-30A				
PG460 30-60A				



PG 2P



PG 4P

3. Outline and Mounting Dimension (mm)

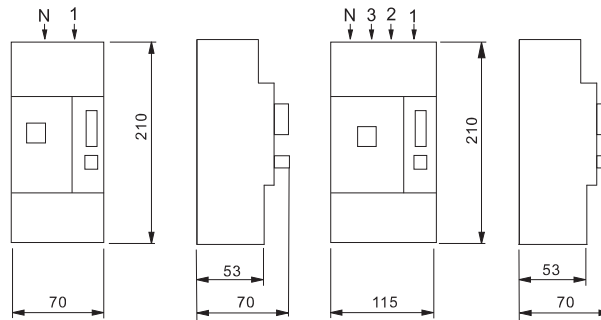

TG Residual Current Circuit Breaker

1. Application

TG is adjustable from 10A up to 60A. It can protect against overload and short circuit. The products comply with IEC61008.

2. Specification

Type	Poles	Rated voltage	Leakage operating current(A)	Leakage non-operating current (A)
TG215 5-15A	2P	230/400V	300mA 500mA	150mA 250mA
TG230 10-30A				
TG260 30-60A				
TG415 5-15A	4P			
TG430 10-30A				
TG460 30-60A				



TG 2P



TG 4P

3. Outline and Mounting Dimension (mm)

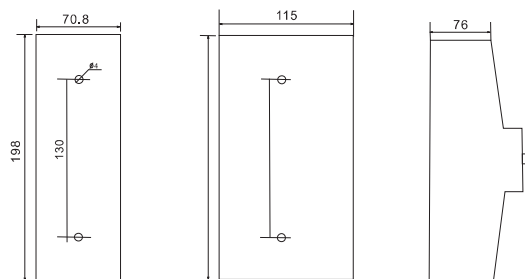

GV Motor Protection Circuit Breaker

GV series motor protection circuit breaker are mainly used for the overload and short circuit protection of the motor in AC 50/60Hz, up to 660V, 0.1-80A power circuit, as a full-voltage starter to start and cut off the motor, under the AC3 load or for the overload and short circuit protection of the circuit and power equipment in the power distribution network.



GV2-M



GV2-ME



GV2-PM



GV3-M



GV3-ME



GV2-AE11



GV2-AN11



GV2-MC

Specification

Type	Standard power ratings of 3-phase motors 50/60Hz in category AC-3						Current setting range (A)
	220V	380V	415V	440V	500V	660V	
	kW	kW	kW	kW	kW	kW	
GV2-MM/ME/PM01	--	--	--	--	--	--	0.1-0.16
GV2-MM/ME/PM02	--	--	--	--	--	--	0.16-0.25
GV2-MM/ME/PM03	--	--	--	--	--	--	0.25-0.4
GV2-MM/ME/PM04	--	--	--	--	--	0.37	0.4-0.63
GV2-MM/ME/PM05	--	--	--	0.37	0.37	0.55	0.63-1
GV2-MM/ME/PM06	--	0.37	--	0.55	0.75	1.1	1-1.6
GV2-MM/ME/PM07	0.37	0.75	0.75	1.1	1.1	1.5	1.6-2.5
GV2-MM/ME/PM08	0.75	1.5	1.5	1.5	2.2	3	2.5-4
GV2-MM/ME/PM10	1.1	2.2	2.2	3	3.7	4	4-6.3
GV2-MM/ME/PM14	2.2	4	4	4	5.5	7.5	6-10
GV2-MM/ME/PM16	3	5.5	5.5	7.5	7.5	9	9-14
GV2-MM/ME/PM20	4	7.5	9	9	9	11	13-18
GV2-MM/ME/PM21	5.5	11	11	11	11	15	17-23
GV2-MM/ME/PM22	5.5	11	11	11	15	18.5	20-25
GV2-MM/ME/PM32	7.5	15	15	15	18.5	26	24-32
GV3-M/ME06	--	0.37	--	0.55	0.75	1.1	1-1.6
GV3-M/ME07	0.37	0.75	1.1	1.1	1.1	1.5	1.6-2.5
GV3-M/ME08	0.75	1.5	1.5	1.5	2.2	3	2.5-4
GV3-M/ME10	1.1	2.2	2.2	3	3.7	4	4-6
GV3-M/ME14	2.2	4	4	4	5.5	7.5	6-10
GV3-M/ME20	4	7.5	7.5	7.5	10	11	10-16
GV3-M/ME25	5.5	11	11	11	15	18.5	16-25
GV3-M/ME40	11	18.5	22	22	25	33	25-40
GV3-M/ME63	15	30	33	33	40	55	40-63
GV3-M/ME80	22	40	45	45	55	63	56-80