

Catalogue

Wenzhou Xucky Electric Co.,Ltd

www.xucky.com



**KWH Meter Panel Meter Multimeter Temperature
Controller Thermocouple Small Thermostat**

DIN-rail KWH Meter

1. Applications

ADM is a kind of single phase electronic Din rail watt-hour meter. It completely accords with relevant technical requirements of class 1 and class 2. It can accurately and directly measure active energy consumption. It can also display total energy consumption by analog type impulse register or LCD display. This watt-hour meter is according to EN62053-21.



ADM25SC



ADM25SCR



ADM65SC



ADM65SCR

Conform to EN62053-21 Accuracy	Class 1, 2
Frequency	50/60Hz
Single phase	120V or 230V
Rated impulse voltage	Uimp 6KV-1.2/50S
Power consumption	≤ 1.5W/6VA per phase
Temperature range	-10°C - +50°C

2. Specification

Type	Rating	Voltage	Class	Designation
ADM25S ADM25SC(LCD) ADM25SCR(RS485)	2.5(10)A 5(20)A 5(25)A 5(30)A	AC120V or 230V	1.0/2.0	Single Phase 1 module
ADM65S ADM65SC(LCD) ADM65SCR(RS485)	5(32)A 10(40)A 10(50)A 15(60)A 20(100)A	AC120V or 230V	1.0/2.0	Single Phase 2 module
ADM100S ADM100SC(LCD) ADM100SCR(RS485) ADM100SCF(Multi-Rate) ADMSCY(Prepaid)	5(30)A 10(60)A 15(90)A 20(100)A	AC120V or 230V	1.0/2.0	Single Phase 4 module



ADM100S



ADM100SC



ADM100SCR

DIN-rail KWH Meter

1. Applications

ADM is a kind of three phase electronic Din rail watt-hour meter. It completely accords with relevant technical requirements of class 1 and class 2. It can accurately and directly measure active energy consumption. It can also display total energy consumption by analog type impulse register or LCD display. This watt-hour meter is according to EN62053-21.

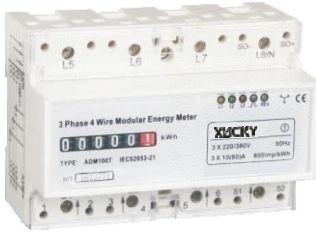

ADM100T

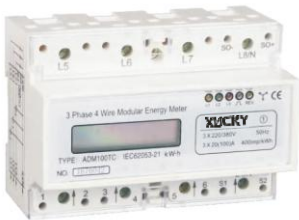

ADM100TC



ADM100TF

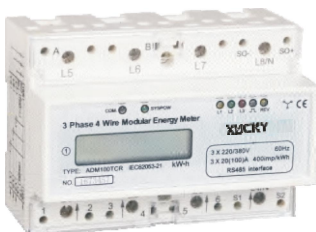

ADM100TCR

Conform to EN62053-21 Accuracy	Class 1, 2
Frequency	50/60Hz
Three phase	230V/400V
Rated impulse voltage	Uimp 10KV-1.2/50S
Power consumption	≤2W/10VA per phase
Temperature range	-10°C - +50°C

2. Specification

Type	Rating	Voltage	Class	Designation
ADM100T	1.5(6)A CT	230/400V	1.0	Three phase 7 module
ADM100TC	3(6)A CT			
ADM100TCR	5(30)A			
ADM100TCF	10(60)A			
	15(90)A			
	20(100)A			

3. Outer and Mount Dimension

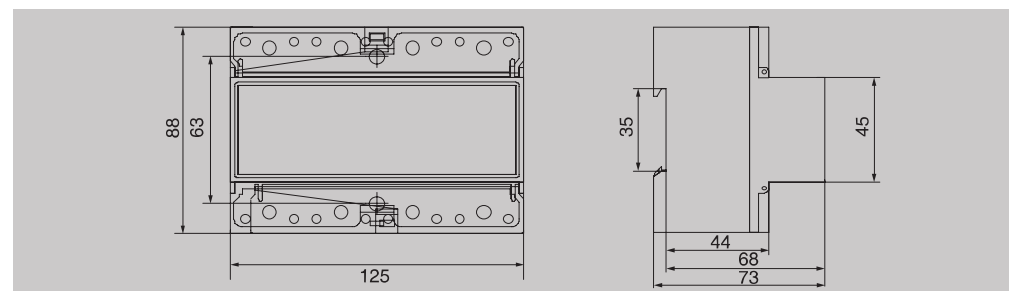

4. Wiring Diagram

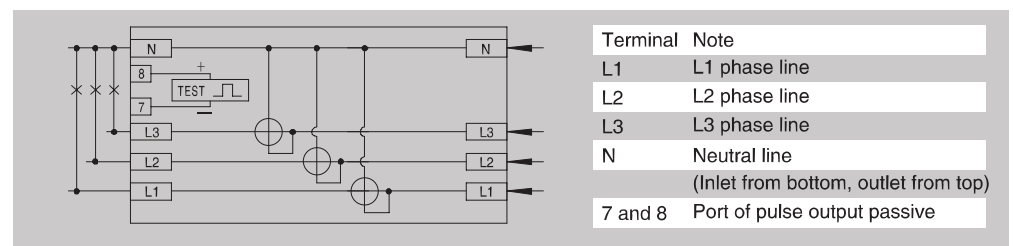

DDS1375 Single Phase Electronic Energy Meter



DDS1375

1. Applications

DDS1375 electronic energy meter is a kind of new style single phase two wire active energy meter. It adopts micro-electronics technique, and imports large scale integrate circuit, uses advanced technique of digital and SMT techniques, etc. The meter completely accord with relevant technical requirements of class 1 single phase active energy meter stipulated in international standard IEC62053-21. It can accurately and directly measure 50Hz or 60Hz active energy consumption from single phase AC electricity net. It's used for setting indoor or outdoors.

2. Specification

Model	Accuracy	Reference Voltage(V)	Current Specifications(A)	Starting Current(A)	Insulation Performance
DDS1375	Class1.0	127	5(30)	0.02	AC voltage 4kV for 1 minute,1.2/50us wave form impulse voltage 6kV
			10(60)	0.04	
		230	20(100)	0.08	



DDS1375

DTS1375,DSS1375 Three Phase Electronic Energy Meter

1. Applications

DTS1375/DSS1375 three phase four wire electronic front board installed active energy meter is a kind of new style three phase four wire active energy meter, it adopts micro-electronics technique and imported large scale integrate circuit, uses advanced technique of digital and SMT techniques, etc. The meter completely accord with relevant technical requirements of class 1 three phase active energy meter stipulated in international standard IEC62053-21. It can accurately and directly measure 50Hz or 60Hz active energy consumption from three phase four wire AC electricity net. It's used for setting indoor or outdoors.

2. Specification

Model	Accuracy	Reference Voltage(V)	Current Specifications(A)	Starting Current(A)	Insulation Performance
DTS1375	Class1.0	3×127/220	1.5(6)	0.02	AC voltage 4kV for 1 minute,1.2/50us wave form impulse voltage 6kV
			3(6)		
			5(20)	0.04	
DSS1375	Class2.0	3×230/400	10(40)		
			15(60)		
			30(100)		



DTS1375

Single Phase Electronic Prepaid Energy Meter

1. Applications



DDSY1375

DDSY1375 type single-phase electronic pre-paid electric meter is developed as a new kind of product by our company, which is based on excellent pre-paid special chips. It has multiple functions, such as electrical energy calculation, load control and user's information management. The product setting charge and adjusting load state in the electric network.

The product can be installed in the electric meter box, indoor or outdoor, the ambient temperature is $-25^{\circ}\text{C}\sim+60^{\circ}\text{C}$. The relative humidity is not more than 85%.

Each of the performance norms of the product accords with IEC61036 static meter international standard and all technical requirements of JB/T8382-1996 pre-paid electric meter standard.

2. Technical Parameters



Rated Current(A)	Rated Voltage(V)	Frequency(HZ)	Accuracy	Starting Current(A)	Power Consumption
1.5(6)	220	50	Class1.0	0.4%(Class1.0)	<2W/5VA
2.5(10)					
5(20)					
10(40)			Class2.0	0.5%(Class2.0)	
15(60)					
20(80)					

*If you need different reference voltage or current specification, please advise our sales

Three Phase Electronic Prepayment Energy Meter

1. Applications



DTSY1375

Type DTSY(DSSY)1375 three-phase electronic prepayment electric energy meter is the metrical instrument controlling electricity by limiting the quantity and load after the user pays the rate to the supply department in advance. It employs the American chip to measure the impulse as well as the latest encrypted IC card to transmit the data. With one card for one user, it is provided with the function for protecting against electricity-theft. Therefore, it is widely applied to industrial or mineral enterprises, real estate management of small residential area, and town and country network reform.

Each of the performance indexes is strictly in conformity to the technical requirements for electronic three-phase prepayment electric energy meter specified in IEC61036 and JB/T8382-96 standards.

2. Technical Parameters



Model	Accuracy	Rated Voltage(V)	Rated Current(A)	Connection Mode
DTSY1375	Class1.0	3x380/220	3x1(2),3x1.5(6),3x3(6)	C.T Type
			3x5(20),3x10(40) 3x15(60),3x20(80)	Direct Type
DSSY1375	Class1.0	3x380	3x1(2),3x1.5(6),3x3(6)	C.T Type
			3x5(20),3x10(40) 3x15(60),3x20(80)	Direct Type

*If you need different reference voltage or current specification, please advise our sales

DD862,DT862,KWH Meter

1. Applications

The series single phase meter is a kind of induction meter to measure the single phase current at the rated frequency of 50Hz. It is an indoor installed meter. Ambient temperature: -10°C to 50°C, relative humidity: below 85% (25°C). DT8 and DT862 series three-phase meter is an induction meter to measure the three-phase current at the rated frequency (50Hz). It is an indoor installed meter; Ambient temperature: -10°C to 50°C, except the first grade is under the working condition of 0 to 40°C. Relative humidity: below 85% (25°C).



DD282



DD862

2. Specification

Item	Type	Accuracy	R.V.	Rated current (A)	Manner
single-phase watt-meter	DD862-4	2	220	2.5(10)5(20)10(40) 15(60)20(80) 30(100)	direct connection connection with
	DD862-2			1.5(6)	current transformer
	DD282 DD28			3(6) 2(4)2.5(5)3(6)5(10) 10(20)20(40)30(60) 40(80)5(20)10(40)	
three phase four-wire watt meter	DT862-4	2	3x380/220	5(20)10(40)15(60) 20(80)3(100)	direct connection
	DT862-2			1.5(6)	connection with current transformer
	DT8			3(6) 10.25.40.80	



DD862

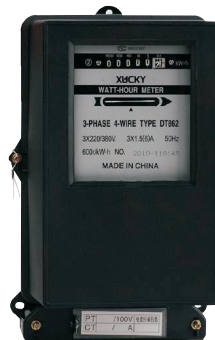

DT862



DT862

Panel Meter



AC Ammeter

Model:AM-96 AM-72 AM-48

Class:1.5

Specs:0.1A 0.5A 1A 1.5A 3A 5A 7.5A 10A 15A 20A 25A 30A 50A 75-105A(use Ext.CT 5A)

Note:for60/75/100A direct meter,the class is 2.5.

Advantage:The scale can be easily changed without opening the front frame so that the class will not be influenced.



DC Ammeter

Model:AM-96 AM-72 AM-48

Class:1.5

Specs:25uA 50uA 1mA 2mA 5mA 10mA 20mA 30mA 50mA 75mA 100mA 150mA 200mA 250mA 300mA 500mA 1A 3A 5A 7.5A 10A 20A 30A 50A 75-105A(used with Shunt)

Feature:The scale can be easily changed without opening the front frame so that the class will not be influenced.



AC Voltmeter

Model:AM-96 AM-72 AM-48

Class:1.5

Specs:30V 50V 75V 100V 120V 150V 250V 300V 450V 600V For 450-380KV,should be used with potential transformer secondary voltage 100V.



DC Voltmeter

Model:AM-96 AM-72 AM-48

Class:1.5

Specs:3V 5V 7.5V 10V 15V 20V 50V 75V 100V 120V 150V 200V 250V 300V 400V 450V 600V

Note:Over 600V should be used with Ext.Resistor.(Rated Cuuent 5mA).



Moving Coil Instruments For Nonelectric Values

Model:AM-96 AM-72

These meters can measure the other non-electric values for example,temperature,speed and so on.



Frequency Meter

Pointer Type

Model:AM-96 AM-72 AM-48

Class:1.0

Volt:50V 100V 220V 380V

Freq:44-55Hz 45-66Hz 55-65Hz 47-53Hz 57-63Hz 44-56Hz 54-66Hz 450-550Hz 550-650Hz

Panel Meter



POWER FACTOR

For 3 phases circuits,balanced load 45-65Hz and for 1 phase AC 50Hz.

Model:AM-96 AM-72

Class:2.5

Voltage:100V 380V 440V

Frequency:50Hz 60Hz

Scale graduation:0.5cap-1-0.5ind 0.3cap-1-0.7ind 0.4cap-1-0.4ind 0.7cap-1-0.3ind.

Orders to be Noted:

Type of Current:1P,3P 3W circuits,balanced load.

Rated Volt:The voltage is line voltage(between two wires).

Operating Current:If used with CT,the secondary current 5A or 1A is standard.



POWER METER

Wattmeters with built-in converter for 1 phase,3P 3W,3P 4W.

Model:AM-96 AM-72

Class:1.5

Voltage:50V 100V 220V 240V 220/380V 240/415V

Current:5a

These meters are used with potential secondary voltage 100V voltage transformer or secondary current 5A CT.wattmeters with built-in converter for 3P 3W,3P 4W and single phase.



MODEL:AM-96 AM-80 AM-72 AM-60 AM-50

Struction:Moving Coil,Moving Iron and Rectifier.

Class:2.0 2.5



Name	Specifications	Remarks
DC Ammeter	30-1000uA 1-1000mA 1K-10KA 1-50A	Direct connection With EXt.Shunt
DC Voltmeter	40-1000mV 1-1000V 1K-10KA 1-50A	Direct connection With EXt.Resistor
DC Ammeter	1-1000mA 5-1000A 1-50A 1K-0KA	Direct connection With EXt.CT
DC Voltmeter	40-1000mV 1-1000V 1K-380KV	Direct connection With EXt.CT
Frequency Meter	Voltage:50-380V Frequency:45-55Hz 45-65Hz 55-65Hz	Only AM-80 is available
Power Factor Meter	Voltage:50-380V Frequency:0.5cap-1-0.5ind 0.3cap-1-0.7ind 0.4cap-1-0.4ind 0.7cap-1-0.3ind Suitable for 1Por 3P3W Circuit	
Power Meter	Voltage:50-380V Current:0.2-5A With Current or Voltage Transformer	

Digital Panel Meter

1.Applications

Digital panel meter which is various and artistic in appearance design is used for dual slope, high precise A/D changeover circuit and high light LED cassette setting specification. It is very convenient for user to fix the equipment.

2.Specification

Description	Direct input range	Input current range	Operation voltage	Display range	Class
AC & DC digital voltage meter	AC DC0-100V	—	AC 220V 50/60Hz	0-1999	0.5
AC & DC digital Ampere meter	AC 10-20A DC 0-10A	—	AC 220V 50/60Hz	0-1999	0.5
Frequency digital meter	AC 10-2KHZ (20-300V)	—	AC 220V 50/60Hz	0-1999	0.5
AC tri-phase watt meter	AC 0-100V	AC 5A	AC 380V 50/60Hz AC 110V 50/60Hz	0-1999	—
AC single-phase watt meter	AC 0-220V	AC 10-5A	AC 220V 50/60Hz AC 110V 50/60Hz	0-1999	—
AC single-phase factor meter	AC 100-300V	AC 5A	AC 220V 50/60Hz	0.5-0-0.5	—



AM72N-A



AM72N-COS



AM72N-W



AM72N-V



AM96N-HZ



AM96N-A/V/HZ



AM72N-V



AM96N-3V/A



AM96N-COS



AM96N-LED



AM96N-A



AM96N-3V

Model FL-2 Current Shunt



1~50A

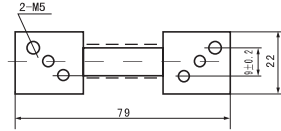
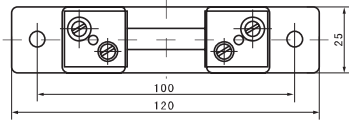

75~100A

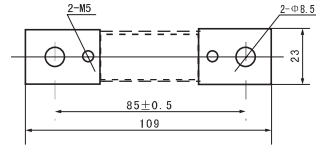

150~200A

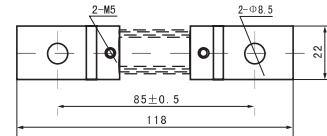
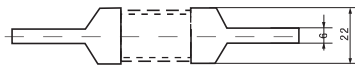

300A

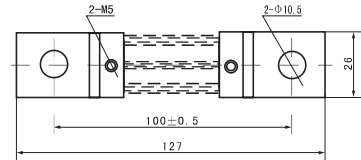
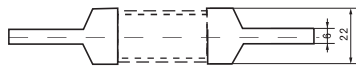

500A

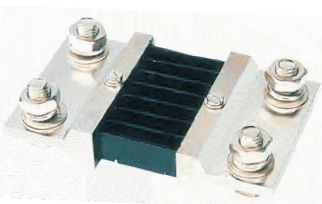
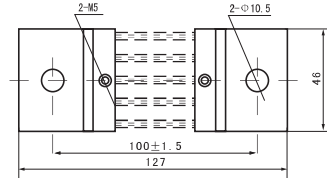

750A

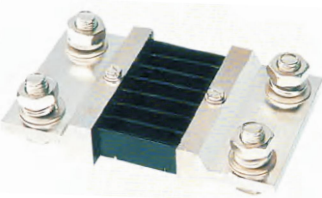
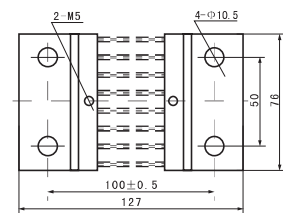
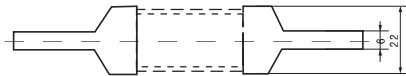

1000A

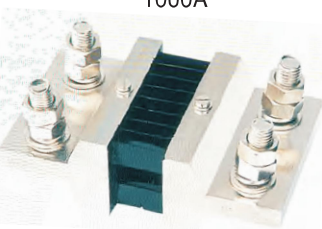
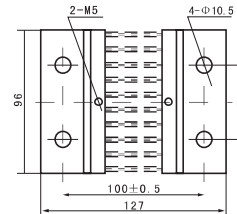
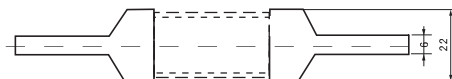

1500A

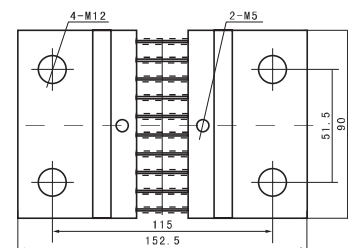

Model FL-21 Current Shunt



5~125A

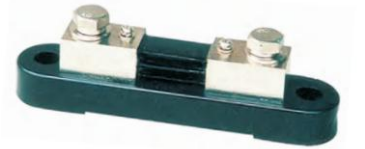
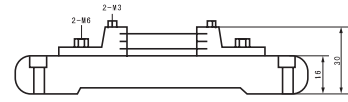
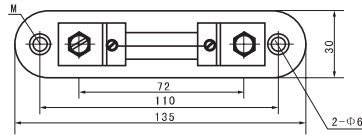

150~200A

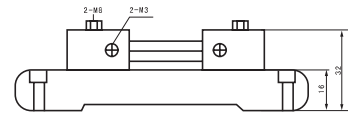
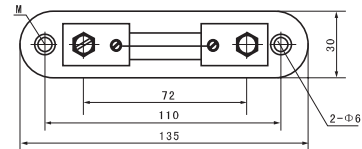

250~600A

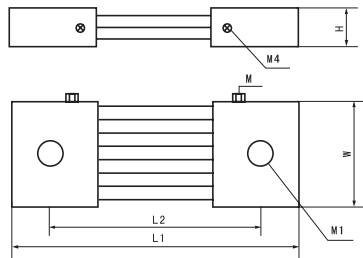

TYPE 50mV	250A	300A	400A	500A	600A
L1	116	116	116	116	122
L2	86	86	86	86	90
W	41	35	44	55	55
H	12	18.5	18.5	18.5	21
M	4	4	4	4	4
M1	13	13	13	13	13
Kg	0.31	0.37	0.49	0.61	0.77



800~1500A

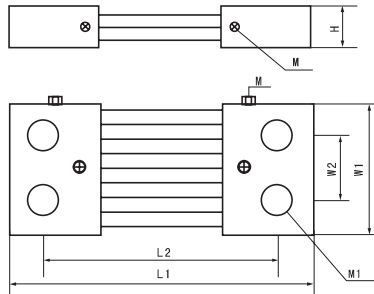

TYPE 50mV	800A	1000A	1200A	1500A
L1	122	159	161	159
L2	90	121	123	121
W1	70	70	85	100
W2	35	35	45	49
H	21	21	21	21
M	4	4	4	4
M1	17	17	17	17
Kg	0.97	1.4	1.7	2.3

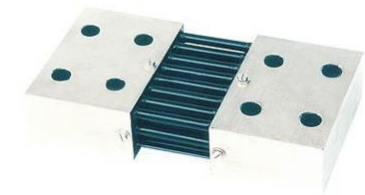

2000~2500A

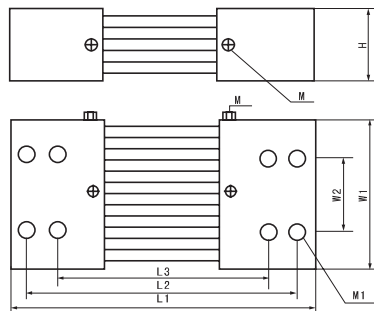

TYPE 50mV	2000A	2500A
L1	190	190
L2	165	165
L3	89	89
W1	100	110
W2	50	55
H	38	38
M	4	4
M1	17	17
Kg	4.7	5.3



3000~6000A

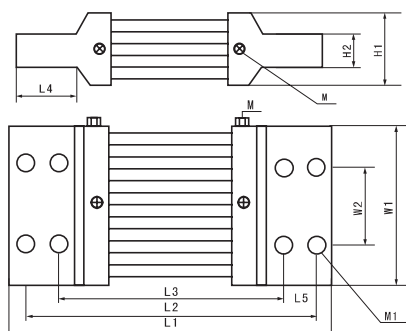

TYPE 50mV	3000A	4000A	5000A	6000A
L1	273	292	315	327
L2	232	253	271	283
L3	142	153	163	185
L4	90	97	100	108
L5	45	50	54	55
W1	103	110	128	133
W2	55	55	60	65
H1	64	82	106	115
H2	28	34	41	48
M	4	4	4	4
M1	17	17	17	17
Kg	7	9.5	15	19.2

MSQ Current Transformer

1. MSQ-A

Primary current: 5A-150A
 Secondary current: 5A,1A
 Standard approval: VDE0414,BS7626,IEC185
 Maximum voltage: 0.66kV
 Frequency: 50/60Hz
 Rated load: 10VA
 Class: 0.5,1.0
 Short-time thermal current: 1th=60Ih
 Rated security coefficient: FS5
 Mounting methods: by once-lead or by copper bar



MSQ-30



MSQ-40



MSQ-60

2. Technical characteristics of current transformers:

WITH BUSBAR

Type	Rated current(A)	Rated power(VA)		Weight (kg)
		Class:0.5	Class:1	
MSQ-A	30/5	5-10	5-10	0.60
	40/5	5-10	5-10	0.60
	50/5	5-10	5-10	0.60
	60/5	5-10	5-10	0.60
	75/5	5-10	5-10	0.60
	80/5	5-10	5-10	0.60
	100/5	5-10	5-10	0.60
	120/5	5-10	5-10	0.60
	125/5	5-10	5-10	0.60
	200/5	5-10	5-10	0.60
	250/5	5-10	5-10	0.60

WINDOWS TYPE

Bar: 30x10mm
 conductor: ø20mm

Type	Rated current(A)	Rated power(VA)		Weight (kg)
		Class:0.5	Class:1	
MSQ-30	30/5	-	1	0.4
	40/5	-	1	0.4
	50/5	-	1	0.4
	60/5	-	1	0.4
	75/5	1	1.5	0.4
	80/5	1.5	2.5	0.4
	100/5	2.5	5	0.4
	150/5	5-10	5-10	0.4
	200/5	5-10	5-10	0.4
	250/5	5-10	5-10	0.4
	300/5	5-10	5-10	0.4

WINDOWS TYPE

Bar:40x10mm
 Conductor:ø30mm

Type	Rated current(A)	Rated power(VA)		Weight (kg)
		Class:0.5	Class:1	
MSQ-40	100/5	2.5	2.5	0.38
	150/5	3	5	0.38
	200/5	5	5-10	0.38



MSQ-80

Type	Rated current(A)	Rated power(VA)		Weight (kg)
		Class:0.5	Class:1	
MSQ-40	250/5	5-10	5-10	0.38
	300/5	5-10	5-10	0.38
	400/5	5-10	5-10	0.38
	500/5	5-10	5-10	0.38

WINDOWS TYPE

Bar:60x20mm
Conductor:ø40mm

Type	Rated current(A)	Rated power(VA)		Weight (kg)
		Class:0.5	Class:1	
MSQ-60	250/5	5	5	0.60
	300/5	5	5	0.60
	400/5	5-10	5-10	0.60
	500/5	5-10	5-10	0.60
	600/5	10-15	10-15	0.60
	750/5	10-15	10-15	0.60
	800/5	10-15	10-15	0.60
	1000/5	15	15	0.60

WINDOWS TYPE

Bar:82x30mm.
Conductor:ø80mm



MSQ-100

Type	Rated current(A)	Rated power(VA)		Weight (kg)
		Class:0.5	Class:1	
MSQ-80	750/5	15	15	0.75
	800/5	15	15	0.82
	1000/5	15	15	0.89
	1200/5	15	15	0.99
	1500/5	15	15	1.02

WINDOWS TYPE

Bar:80x30mm.or 100x10mm.
Conductor:ø60mm

Type	Rated current(A)	Rated power(VA)		Weight (kg)
		Class:0.5	Class:1	
MSQ-100	1500/5	15	15	0.80
	1600/5	15	15	0.80
	2000/5	15	15	0.94
	2250/5	15	15	0.98
	2500/5	15	15	1.10
	3000/5	15	15	1.16

WINDOWS TYPE

Bar:125x57mm.or 125x10mm.
Conductor:ø60mm



MSQ-125

Type	Rated current(A)	Rated power(VA)		Weight (kg)
		Class:0.5	Class:1	
MSQ-125	1500/5	15	15	1.0
	2000/5	15	15	1.15
	2500/5	15	15	1.45
	3000/5	15	15	1.60
	4000/5	15	15	1.90
	5000/5	15	15	2.20

MR Current Transformer



MR-28

1. MR Series

Primary current: 30A-5000A
 Secondary current: 5A, 1A
 Standard approval: BS7626, IEC185
 Maximum voltage: 0.72 kV
 Frequency: 50/60Hz
 Rated load: 5VA-15VA
 Class: 1.0, 3.0
 Short-time thermal current: 1th=60 x I_n
 Rated security coefficient: FS<5



MR-45

2. Specification

Class: 0.5 1.0 3.0

Type	Current	ID(mm)	OD(mm)	TD(mm)
MR-28	30/5A-60/5A	28	70	40
MR-42	100/5A~250/5A	42	80	30
MR-45	300/5A	45	80	30
MR-60	400/5A~600/5A	60	100	30
MR-85	800/5A~1600/5A	85	120	20
MR-125	2000/A~5000/5A	125	165	20



MR-60

Noted: For measuring current transformers the accuracy class is designated by the highest permissible percentage current(ratio)error at the rated current perscribed for the ac curacy class concerned.

3. Outline Drawing



MR-85

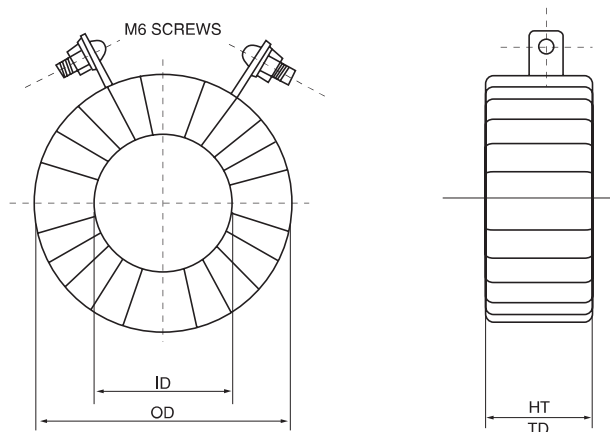

RCT Current Transformer



RCT-25

1. RCT Series

Primary current:	30A-3000A
Secondary current:	5A,1A
Standard approval:	IEC44-1
Maximum voltage:	0.66kV
Frequency:	50/60Hz
Rated load:	15VA
Class:	1.0
Short-time thermal current:	1th=60 x I _n
Rated security coefficient:	FS<5

2. Specification

Model	Primary/secondary
RCT-25	15/5A 20/5 30/5 40/5 50/5 60/5 75/5 100/5A
RCT-35	30/5 50/5 60/5 80/5 100/5 120/5 150/5 200/5 250/ 300/5A
RCT-60	300/5 400/5 500/5 600/5 800/5 1000/5 1200/5A
RCT-90	1000/5 1200/5 1500/5 1600/5 2000/5A
RCT-110	2000/5 2500/5 3000/5 4000/5 5000/5A

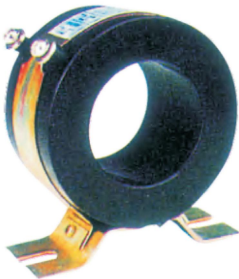

RCT-60

3.Outline and Installation Dimension (mm)

Dimension of case unit:mm

Model	RCT-25	RCT-35	RCT-60	RCT-90	RCT-110
A	93	93	93	93	102
B	78	78	78	78	86
V	25	32	60	90	111
D	78	78	104	136	157
E	2	2	2	2	2
F	55	55	41	41	52
G	9	9	9	9	9



RCT-110

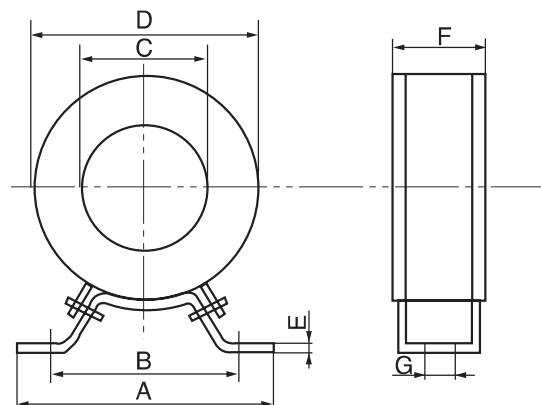

DP Current Transformer

1. Split core current transformers DP series



The DP series of current transformers have been especially designed to facilitate their installation in new or already existing networks. They may be installed without opening any cable or bus bar circuit.

The connection of conventional CTs usually requires the interruption of the primary side circuit to pass cables or bus bars through the transformer core or to connect such cables to the primary terminals. The DP series transformers core may be easily opened and they may be installed and connected without any supply interruption, thus saving time and installation costs.

The main features of DP transformers are:

- Small size and easy mounting.
- Wide inner window, allowing clamping of big cables or bus bars.
- Wide range of sizes to accommodate all the existing installations.
- High accuracy and reliability.

2. Split core current transformers DP series



Primary current	100A-5000A
Secondary current	5A,1A
Standard approval	IEC44-1, BS7626
Maximum voltage	0.72/3kV
Frequency	50/60Hz
Rated load	1VA-30VA
Class	0.5, 1.0, 3.0
Short-time thermal current	$I_{th}=100 \times I_n$
Rated security coefficient	FS<5

3. Outline and Installation Dimension(mm)

Model	A	B	C	D	E	F	G	H	I	Weight(kg)
DP-23	20	30	51	89	111	34	47	40	32	0.75
DP-58	50	80	78	114	145	32	32	32	33	0.90
DP-88	80	80	108	144	145	32	32	32	33	1.05
DP-812	80	120	108	144	185	32	32	32	33	1.25
DP-816	80	160	120	184	245	52	52	52	38	4.3

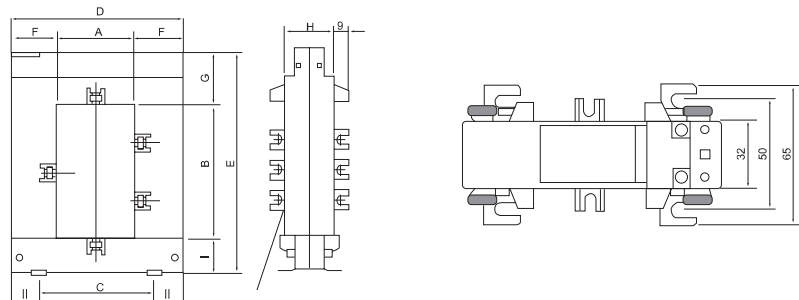

4. Specification

Model	Nominal current ratio	Burden VA	
		Class:0.5	Class:1
		VA	VA
DP-23	100		
	150		
	200		1.5
	250		2
	300	1.5	3.75
	400	2.5	6
DP-58	250	1.5	2
	300	1.5	3
	400	1.5	3
	500	2.5	5
	600	2.5	5
	750	2.5	6
	800	2.5	7.5
	1000	5	10
DP-88	250	1.5	3.75
	300	1.5	6
	400	1.5	10
	500	2.5	15
	600	2.5	17.5
	750	2.5	18
	800	2.5	18
	1000	5	20
DP-812	500	2.5	12
	600	2.5	15
	750	2.5	17.5
	800	2.5	18
	1000	5	20
	1200	6	25
	1250	7.5	25
	1500	7.5	30
DP-816	1000	10	20
	1500	15	25
	2000	15	25
	2500	15	25
	3000	20	30
	4000	20	30
	5000	20	30

LZZBJ9-10 Type Current Transformer

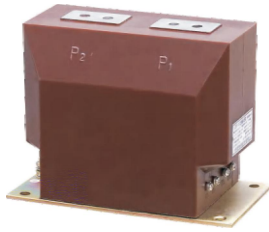

1. Type and Meaning

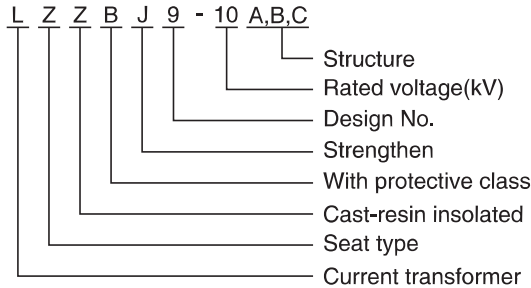

2. Specification

Type	Rated transformation ratio(A)	Accuracy Classes combination	Accuracy class and rated output COSφ=0.8				1s thermal current(kA)	Rated dynamic current(kA)
			0.2S	0.2	0.5	10P15		
LZZBJ9-10A1G	5/5	0.2S/0.5	10	10	10	15	0.8	1.9
	10/5	0.2S/0.25					1.5	3.8
	15/5	0.2S/10P15					2.3	5.8
	20/5	0.2/10P15					3	7.5
	30/5	0.5/10P15					4.5	11.2
LZZBJ9-10B	40/5	0.2/0.5/10P15	10	10	10	15	6	15
LZZBJ9-10C	50/5	0.2S/0.5/10P15					7.5	18.8
	LZZBJ9-10C	75/5					0.2S/10P20	11.5
100/5		0.2/10P20					15	37.5
150-200/5		0.5/10P20					22.5	56.5
300-600/5		0.2S/10P30					45	112.5
800-2500/5		0.5/10P30					63	157.5

Note: any special requirements can be negotiated with us,thermal and heat both stable,we can customized your requirement.

3. Overall Dimension Drawing

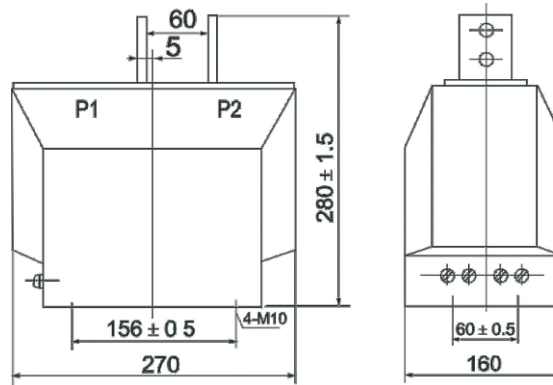

LZZBJ9-10

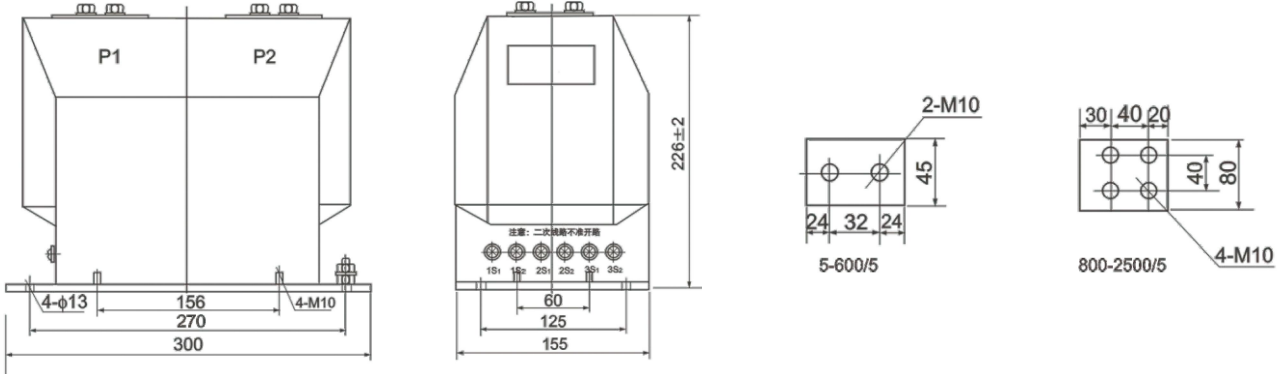

LZZBJ9-10C

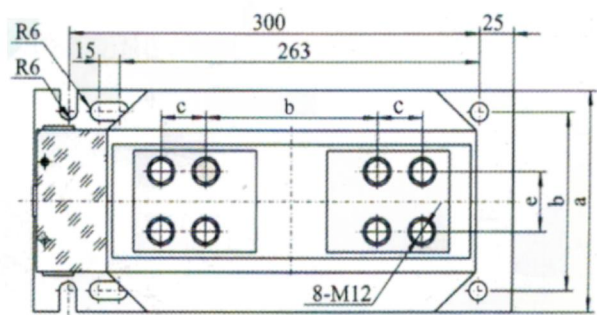
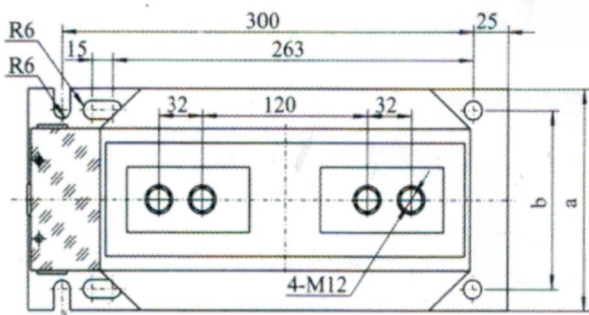
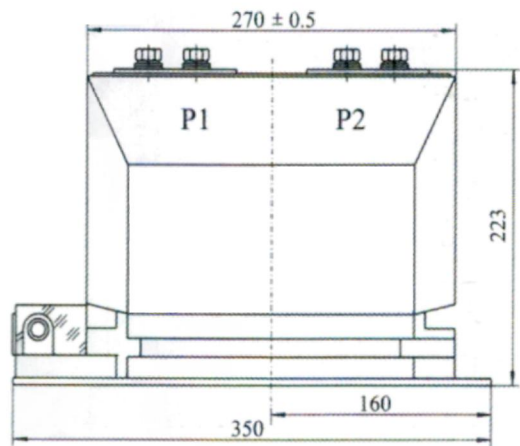
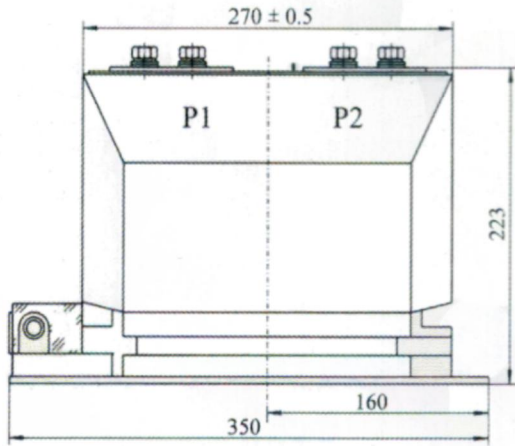

Rated Primary Current		5-600/5		800-2500/5					3100-3150				
Dimension Code		a	b	a	b	c	d	e	a	b	c	d	e
Type	LZZBJ9-10A1G	155	125	155	125	24	120	40					
	LZZBJ9-10A2G	175	145	175	145	24	120	40	175	145	40	100	50

LZZBJ9-12 Type Current Transformer



1. Type and Meaning

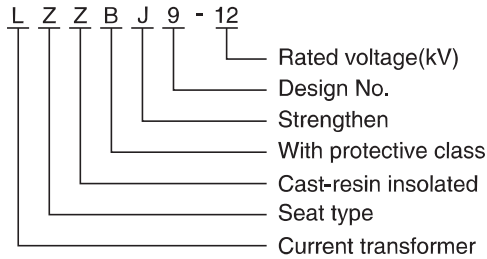

2. Specification

Type	Rated transformation ratio(A)	Accuracy Classes combination	Accuracy class and rated output COSφ=0.8				1s thermal current(kA)	Rated dynamic current(kA)
			0.2S	0.2	0.5	10P15		
LZZBJ9-12 (AS12/150b/2S) (AS12/150b/4S) (AS12/175b/2S) (AS12/175b/4S)	5/5	0.2S/10P15	10	10	10	15	0.8	1.9
	10/5						1.5	3.8
	15/5						2.3	5.8
	20/5	0.2/10P15					3	7.5
	30/5						4.5	11.2
	40/5	0.5/10P15					6	15
	50/5						7.5	18.8
	75/5						11.5	29
	100/5	0.5/10P15					15	37.5
	150-200/5						22.5	56.5
	300-600/5						45	112.5
	800-2500/5						63	157.5

Note: any special requirements can be negotiated with us,thermal and heat both stable,we can customized your requirement.

3. Outline and Mounting Dimension

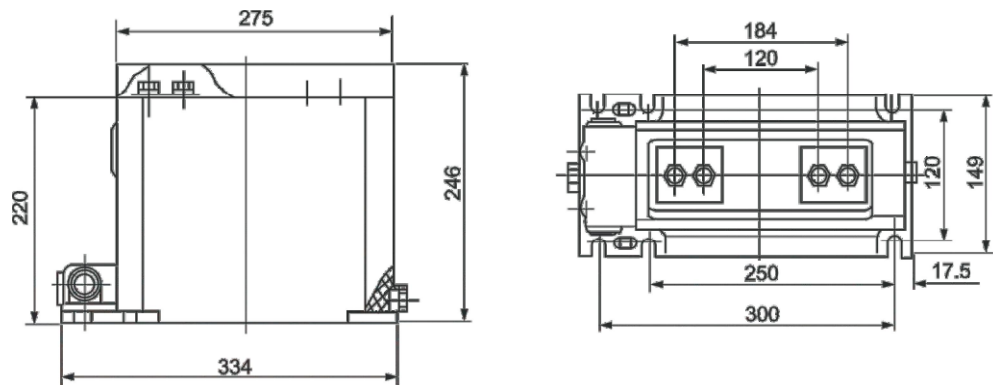

LZZBJ9-12(AS12/150b2S)

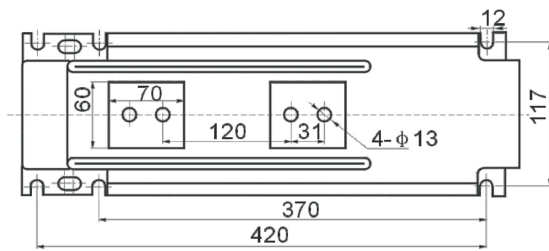
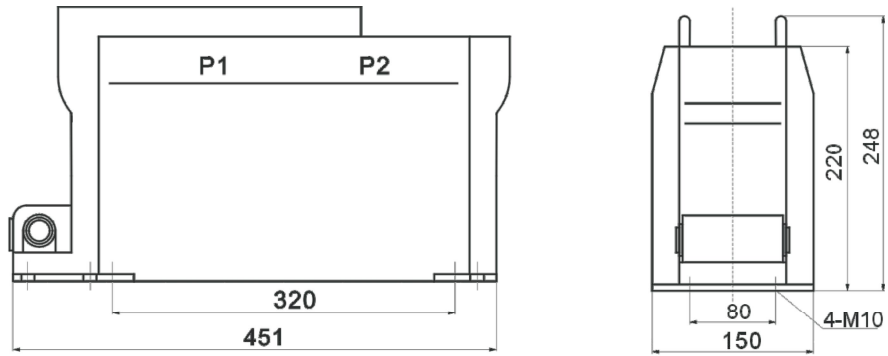

LZZBJ9-12(AS12/150b/4S)

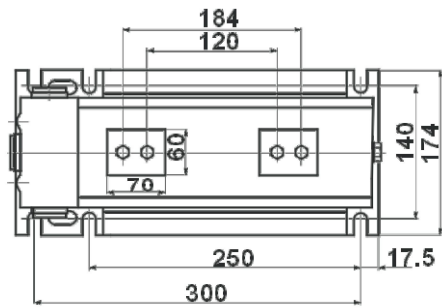
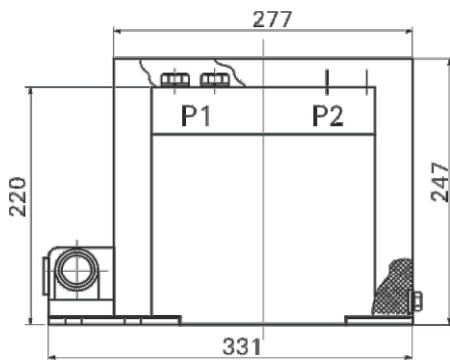

LZZBJ9-12(AS12/175b/2S)

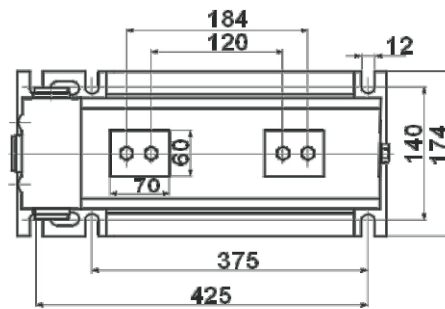
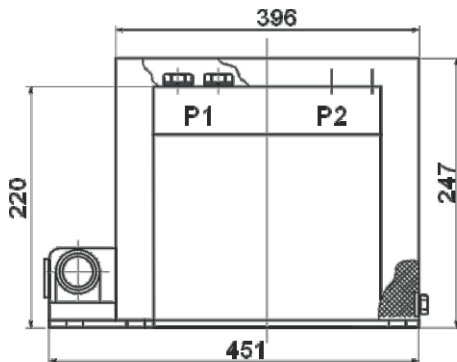

LZZBJ9-12(AS12/175b/4S)

LZZBJ9-36/250W1G1 Type Current Transformer

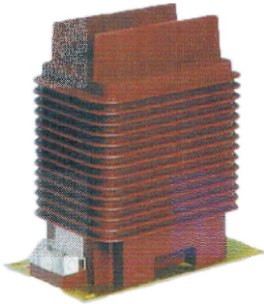

1. Type and Meaning

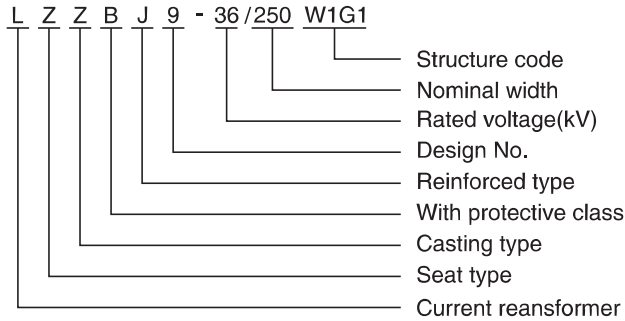

2. Specification

Type	Rated primary current I _n (A)	Accuracy Classes combination	Rated secondary output(A)			Short-time thermal current(kA/S)	Rated dynamic current(kA)
			0.2	0.5	5P20		
LZZBJ9-36	20-100	0.2S/0.2S	10	15	15	200I _n	500I _n
	150-200	0.2S/0.5	10	15	15	31.5	80
	300-500	0.5/0.5	10	15	15	31.5/2	80
	600-1250	0.2S/5P20	15	30	20	31.5/4	31.5/4
	1500-2000	0.5/5P20	20	40	30	40/4	125
	2500	0.2S/0.5/5P20	20	40	20	40/4	125

Note: any special requirements can be negotiated with us, thermal and heat both stable, we can customized your requirement.

3. Outline and Mounting Dimension

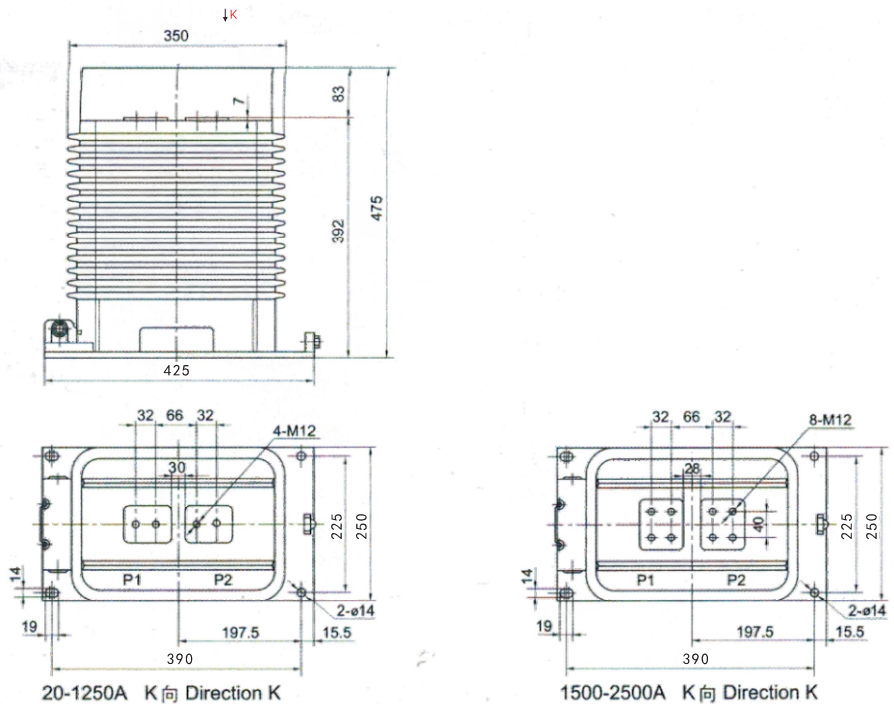

LZZBJ71-12,27.5,35 Type Outdoor Current Transformer

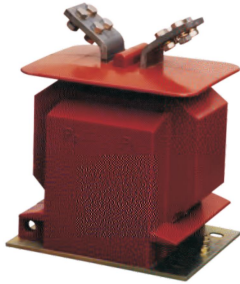

1. Type and Meaning

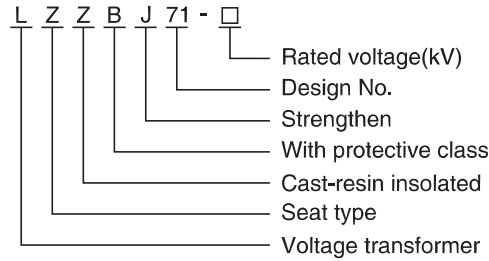

2. Specification



Type	Rated transformation ratio(A)	Accuracy Classes combination	Accuracy class and rated output COSØ=0.8				1s thermal current(kA)	Rated dynamic current(kA)		
			0.2S	0.2	0.5	10P10				
LZZBJ71-12	5-100/5	0.2S/10P15	10	15	20	20	200I In	500I In		
	150-300/5						150I In	375I In		
	400/5						45	112.5		
	500/5	0.2/10P15					63	157.5		
	600/5									
	800/5	0.5/10P15					80	200		
	1000/5									
1500/5										
LZZBJ71-27.5	5-100/5	0.2S/10P15	10	15	20	30	150I In	375I In		
LZZBJ71-35	150/5						22.5	57		
	200/5						27.5	69		
LZZBJ71-35	300/5	0.2/10P15					63	157.5		
	400/5								45	112.5
	500/5	0.5/10P15							80	200
	600/5									
	800/5									
1000-2500/5										

Note: any special requirements can be negotiated with us,thermal and heat both stable,we can customized your requirement.

3. Outline and Mounting Dimension

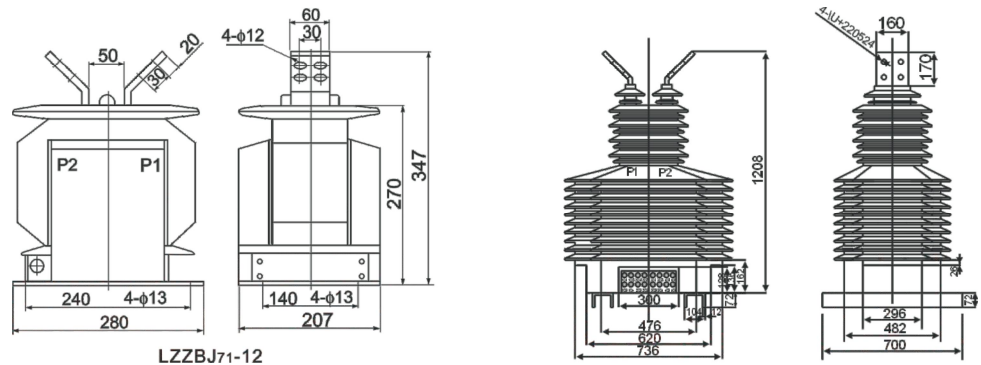

JDZ,JDZJ-6,10 Type Voltage Transformer



1. Type and Meaning

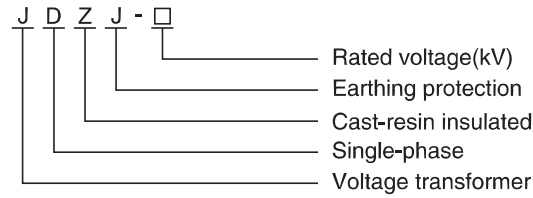

2. Specification



Type	Rated transformation ratio(A)	Accuracy class and rated output COSφ=0.8					Thermal limiting output(VA)	Rated insulation level(kV)
		0.2	0.5	1	3	3P 6P		
JDZ-6(Q)	3000/100	15	30	50	80		200	3.6/24/40
	6000/100	20	30	80	200		400	7.2/32/60
JDZ-10(Q)	10000/100	30	80	120	300		500	12/42/75
	10000/200							
	11000/100							
JDZJ-6(Q)	$\frac{3000}{\sqrt{3}} / \frac{100}{\sqrt{3}} / \frac{100}{3}$	15	30	50	80	100	200	3.6/24/40
	$\frac{6000}{\sqrt{3}} / \frac{100}{\sqrt{3}} / \frac{100}{3}$	20	30	80	200	100	400	7.2/32/60
JDZJ-10(Q)	$\frac{10000}{\sqrt{3}} / \frac{100}{\sqrt{3}} / \frac{100}{3}$	20	50	80	200	100	400	12/42/75
	$\frac{11000}{\sqrt{3}} / \frac{100}{\sqrt{3}} / \frac{100}{3}$							

Note: any special requirements can be negotiated with us.

3. Outline and Mounting Dimension

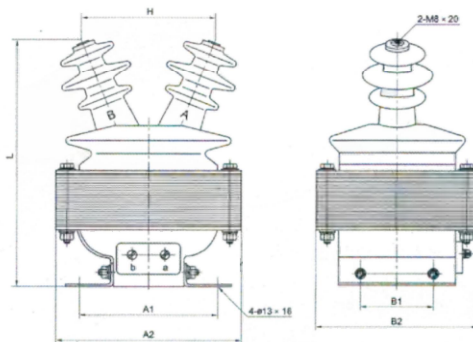

Type	H	L	A1	A2	B1	B2
JDZ-10Q	165	315	170	230	90	202
JDZ-3, 6Q	160	285	168	216	90	188

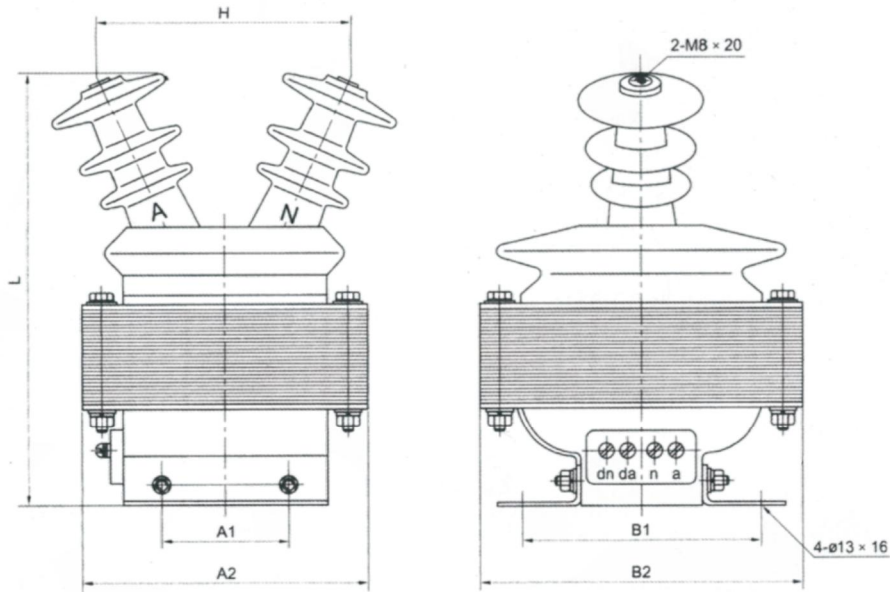

Type	H	L	A1	A2	B1	B2
JDZJ-10Q	180	315	90	202	170	230
JDZJ-3, 6Q	160	285	90	188	168	216

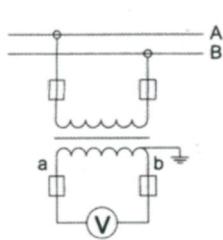

(Figure 1)

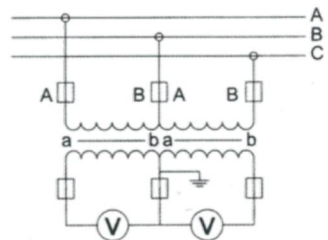

(Figure 2)

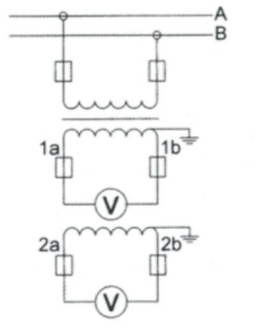

(Figure 3)

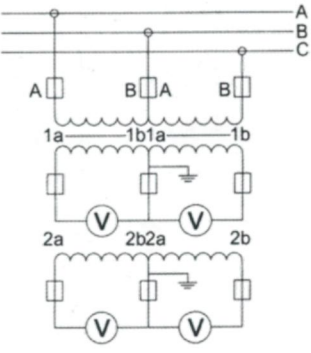

(Figure 4)

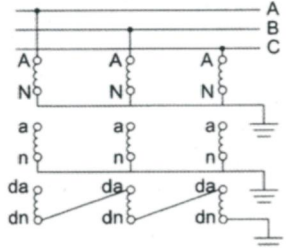

(Figure 5)

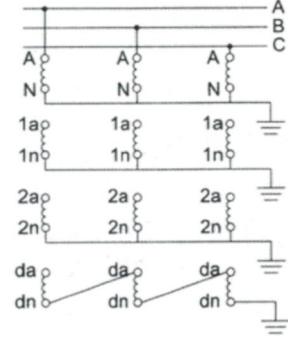

(Figure 6)

JDZC-6,10 Series Voltage Transformer

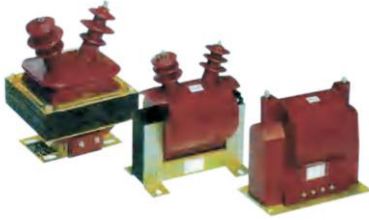

1. Type and Meaning

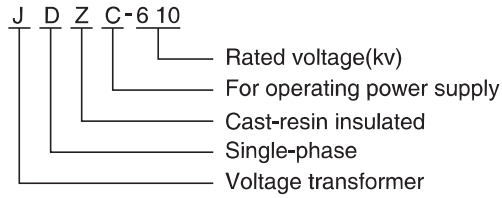

2. Specification

Type	Rated transformation ratio(V)	Accuracy class and rated output COS ϕ =0.8		Thermal limiting output(VA)	Rated insulation level(kV)
		1a1b(100v)	2a2b(220v)		
JDZC-6	6000/100/200	30	500-700	400	7. 2/32/60
		50	800-1500		
JDZC-10	10000/100/200	80	2000	600	12/42/75

Note: any special requirements can be negotiated with us.

3. Outline and Mounting Dimension

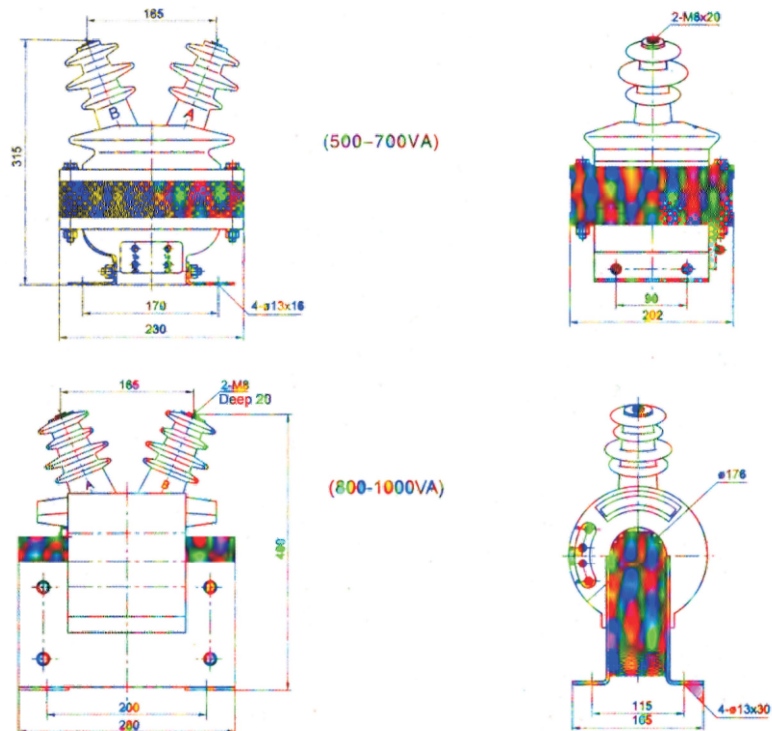

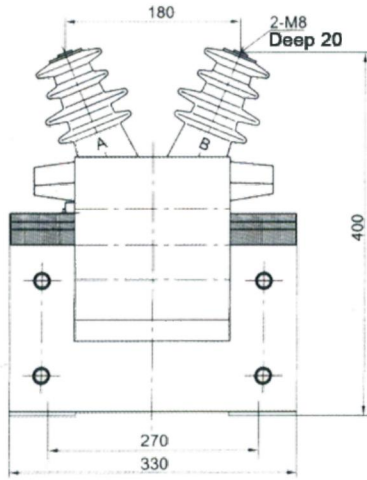

(1500-2000VA)

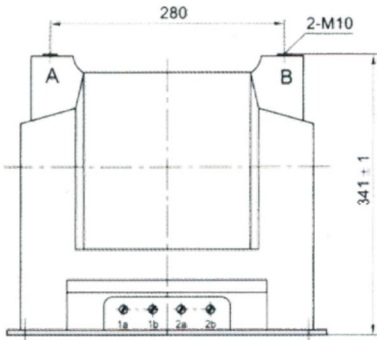
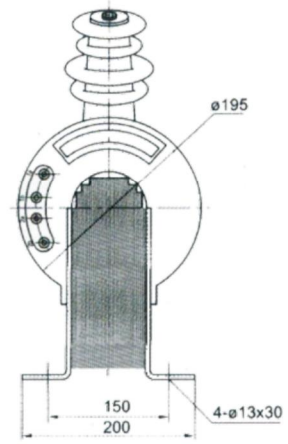

(3000VA)

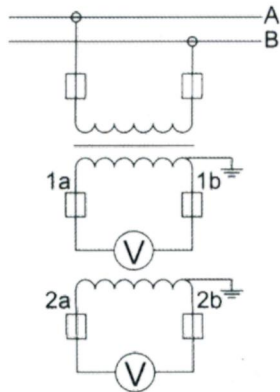
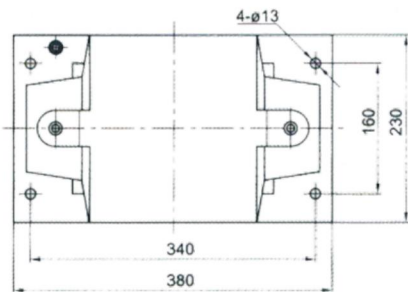
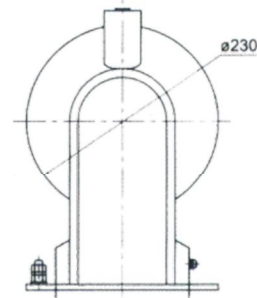

(Figure 1)

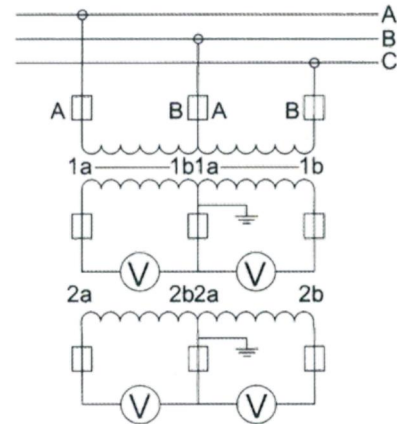

(Figure 2)

JDZ9-6,10 Type Voltage Transformer



1. Type and Meaning

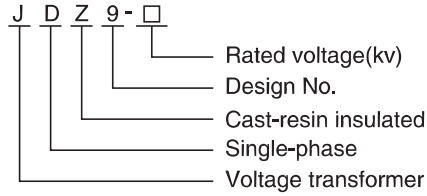

2. Specification

Type	Rated transformation ratio(V)	Accuracy class and rated output COSφ=0.8					Thermal limiting output(VA)	Rated insulation level(kV)
		0.2	0.5	1	3	3P 6P		
JDZ9-6	6000/100	20	50	100	150	200	400	7. 2/32/60
JDZ9-10	10000/100	30	80	200	240	240	600	12/42/75

Note: any special requirements can be negotiated with us.

3. Outline and Mounting Dimension

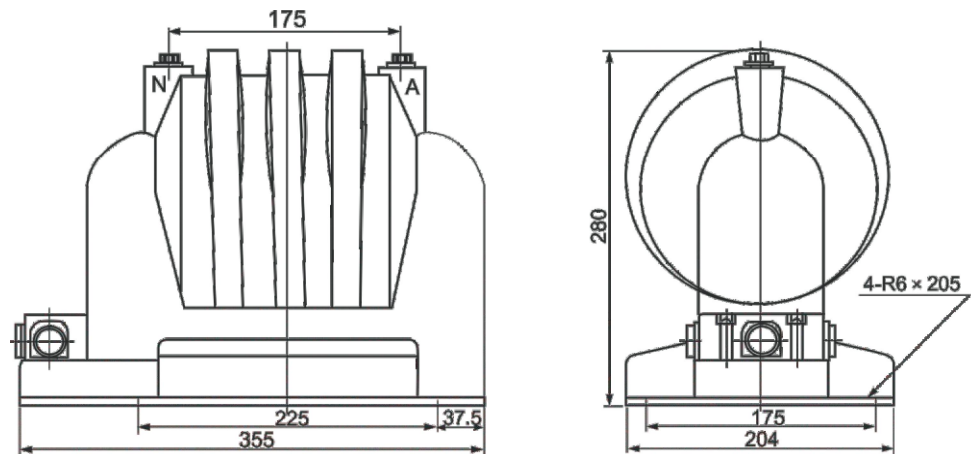

JDZX9-6,10 Type Voltage Transformer



1. Type and Meaning

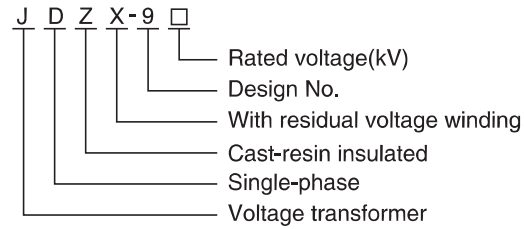

2. Specification

Type	Rated transformation ratio(V)	Accuracy class and rated output COSØ=0.8					Thermal limiting output(VA)	Rated insulation level(kV)
		0.2	0.5	1	3P	3P 6P		
JDZX9-6	$\frac{6000}{\sqrt{3}} / \frac{100}{\sqrt{3}} / \frac{100}{3}$	15	30	100	100	100	400	7.2/32/60
JDZX9-10	$\frac{10000}{\sqrt{3}} / \frac{100}{\sqrt{3}} / \frac{100}{3}$	25	50	180	100	100	600	12/42/75

Note: any special requirements can be negotiated with us.

3. Outline and Mounting Dimension

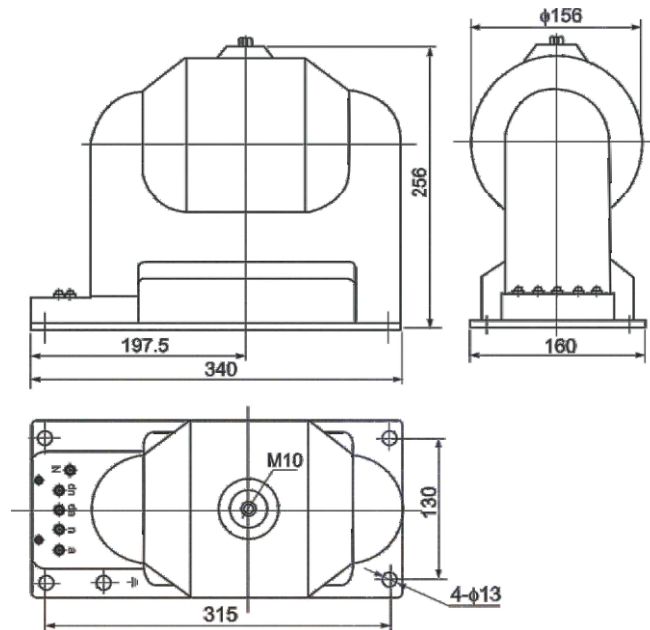

JDZ10-10 Type Voltage Transformer(Same RZL-10)

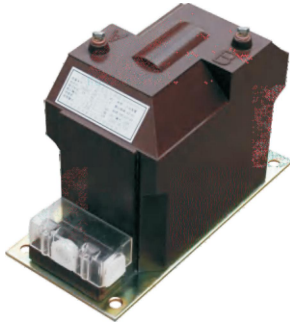

1. Type and Meaning

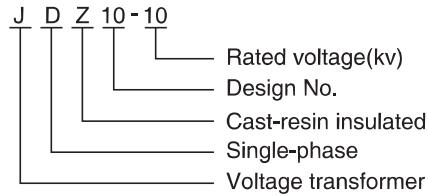

2. Specification

Type	Rated transformation ratio(V)	Accuracy class and rated output COS ϕ =0.8					Thermal limiting output(VA)	Rated insulation level(kV)
		0.2	0.5	1	3	3P 6P		
JDZ10-10 (RZL-10)	6000/100	15	30	60	50	50	200	7. 2/32/60
	10000/10	15	30	60	50	50	200	12/42/72

Note: any special requirements can be negotiated with us.

3. Outline and Mounting Dimension

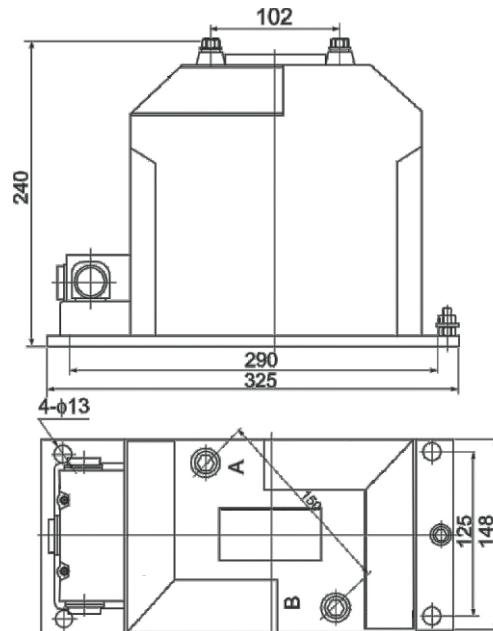

JDZX10-10 Type Voltage Transformer(Same REL-10)



1. Type and Meaning

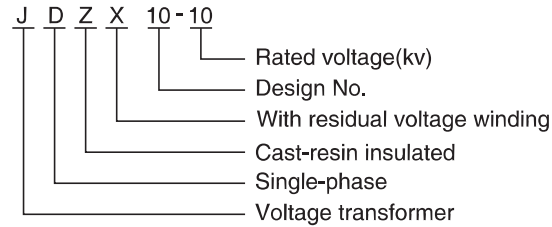

2. Specification

Type	Rated transformation ratio(V)	Accuracy class and rated output COSØ=0.8					Thermal limiting output(VA)	Rated insulation level(kV)
		0.2	0.5	1	3	3P 6P		
JDZX10-10 (REL-10)	$\frac{6000}{\sqrt{3}}/\frac{100}{\sqrt{3}}/\frac{100}{3}$	15	30	60	50	50	200	7.2/32/60
	$\frac{10000}{\sqrt{3}}/\frac{100}{\sqrt{3}}/\frac{100}{3}$	15	30	60	50	50	200	12/42/75

Note: any special requirements can be negotiated with us.

3. Outline and Mounting Dimension

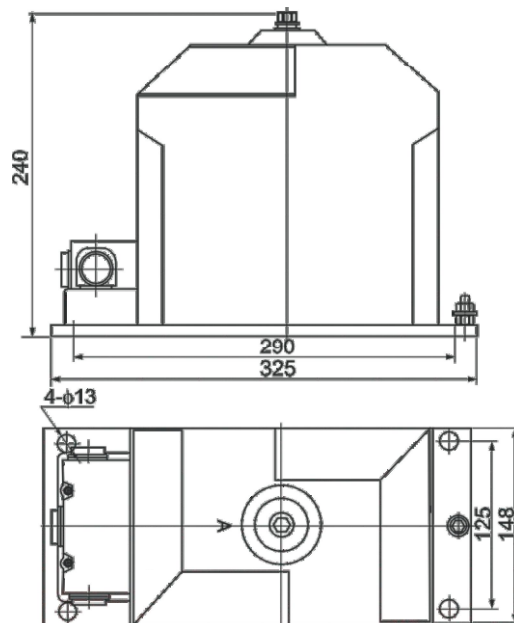



JDZ9-35Q,JDZX9-35G Type Voltage Transformer

1. Type and Meaning

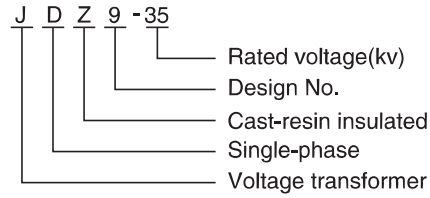

2. Specification

Type	Rated transformation ratio(V)	Accuracy class and rated output COS ϕ =0.8					Thermal limiting output(VA)	Rated insulation level(kV)
		0.2	0.5	0.2/0.5	0.5/0.5	3P 6P		
JDZ9-35	35000/100	60	120				800	40.5/95/200
	35000/100/100			30/80	40/80		400	

Note: any special requirements can be negotiated with us.

3. Outline and Mounting Dimension

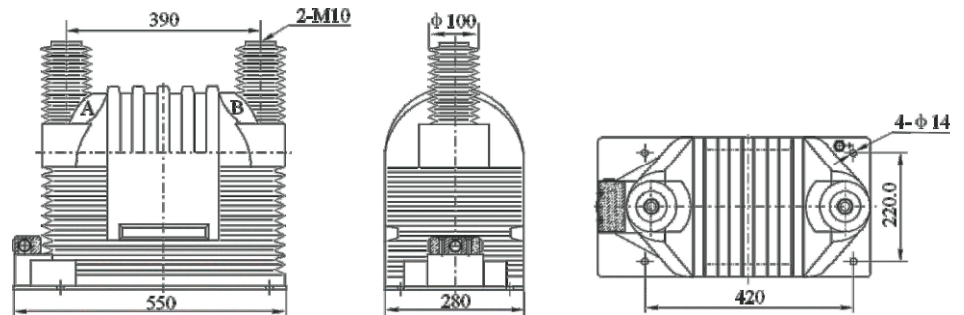

JDZX9-35(W) Type Voltage Transformer

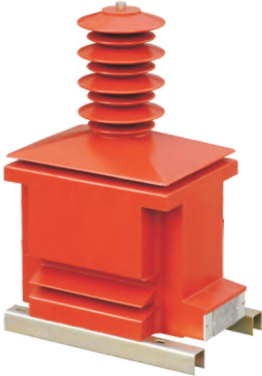

1. Type and Meaning

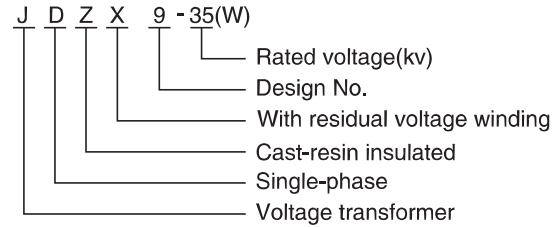

2. Specification

Type	Rated transformation ratio(V)	Accuracy class and rated output COSφ=0.8					Thermal limiting output(VA)	Rated insulation level(kV)
		0.2	0.5	0.2/0.5	0.5/0.5	3P 6P		
JDZ9-35(W)	$\frac{35000}{\sqrt{3}} / \frac{100}{\sqrt{3}} / \frac{100}{3}$	40	80			100	600	40.5/95/200
	$\frac{35000}{\sqrt{3}} / \frac{100}{\sqrt{3}} / \frac{100}{\sqrt{3}} / \frac{100}{3}$			20/50	30/30	100	300	

Note: any special requirements can be negotiated with us.

3. Outline and Mounting Dimension

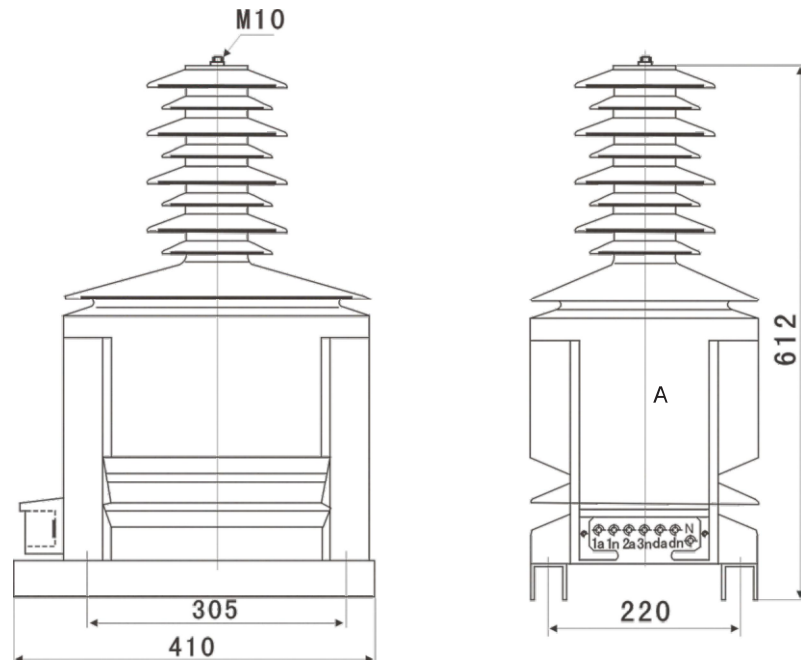

JDZXW-35 Type Voltage Transformer

1. Type and Meaning

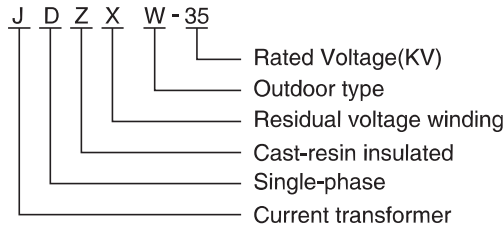

2. Specification

Type	Rated transformation ratio(V)	Accuracy class and rated secondary output(VA)						Thermal limiting output(VA)	Rated insulation level(kV)	
		0.2	0.5	1	3	0.2/0.2 0.2/0.5	0.5/0.5 6P			
JDZXW-35	$\frac{35000}{\sqrt{3}}/\frac{100}{\sqrt{3}}/\frac{100}{3}$	30	90	180	500	/	/	100	600	40.5/95/200
	$\frac{35000}{\sqrt{3}}/\frac{100}{\sqrt{3}}/\frac{100}{3}$	/	/	/	/	20/20 20/30	45/45	100	300/300	

Note: any special requirements can be negotiated with us.

3. Outline and Mounting Dimension

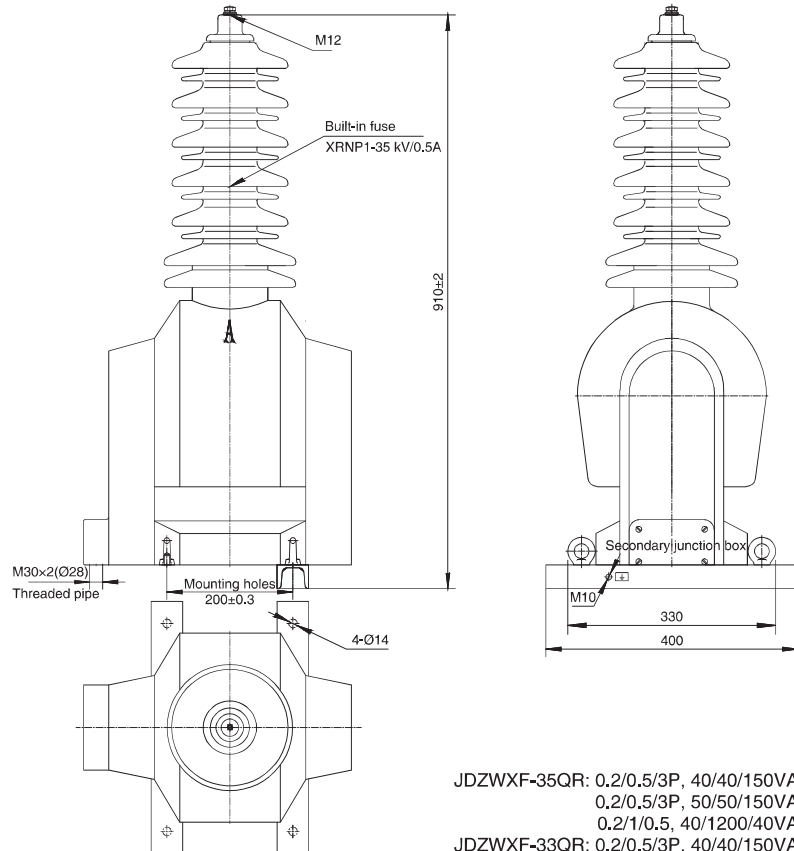

JDZW-35 Voltage Transformer

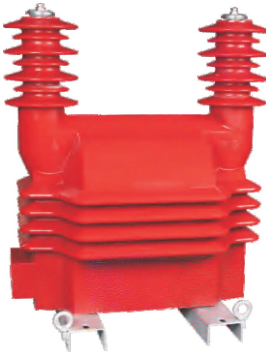

1. Type and Meaning

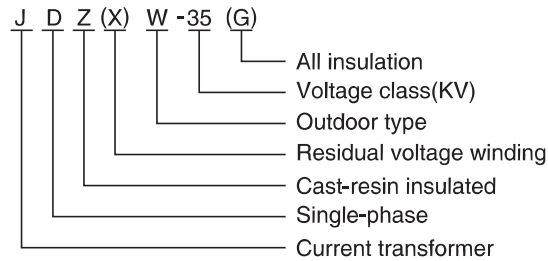

2. Specification

Type	Rated transformation ratio(V)	Accuracy class and rated secondary output(VA)							Thermal limiting output(VA)	Rated insulation level(kV)
		0.2	0.5	1	3	0.2/0.2 0.2/0.5	0.5/0.5	6P(3P)		
JDZW-35	35000/100	60	150	300	600	/	/	/	1200	40.5/95/200
	35000/100/100	/	/	/	/	30/30 30/40	60/60	/	600/600	
JDZXW-35G	$\frac{35000}{\sqrt{3}} / \frac{100}{\sqrt{3}} / \frac{100}{3}$	90	200	500	/	/	/	100	600	
	$\frac{35000}{\sqrt{3}} / \frac{100}{\sqrt{3}} / \frac{100}{\sqrt{3}} / \frac{100}{3}$	/	/	/	/	15/15 15/20	30/30	100	300/300	

Note: any special requirements can be negotiated with us.

3. Outline and Mounting Dimension

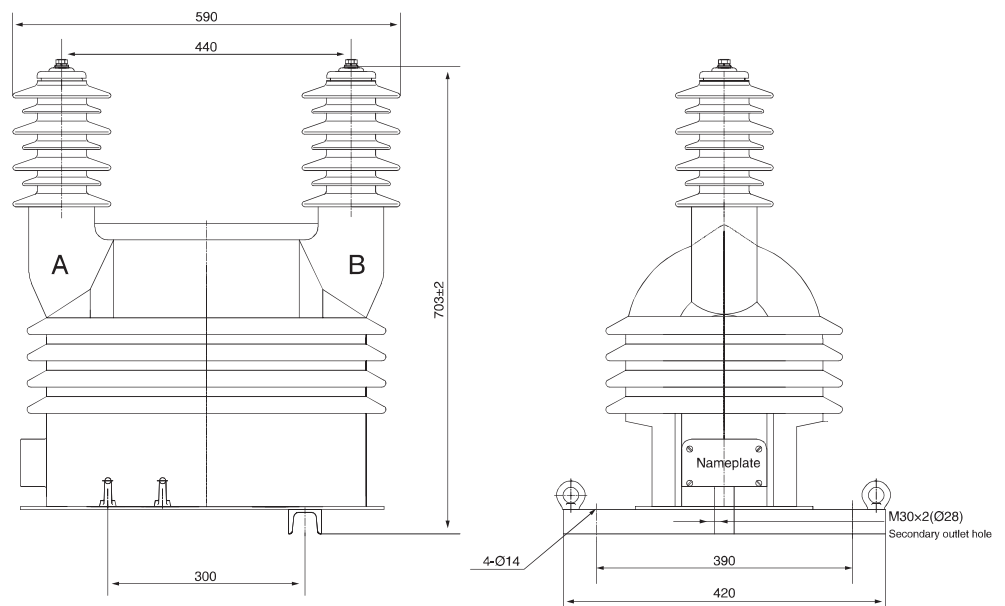

JDZW-35CQ: 0.5, 60VA
 JZW-35:0.2/0.2, 40/40VA1,1200VA
 JZW-33:0.2/0.2, 40/40VA

JLS-6,10,35 Type Outdoor Combined Transformer



1. Type and Meaning

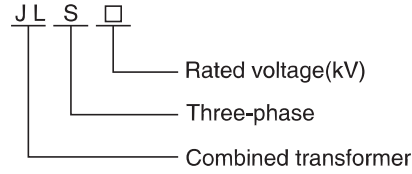

2. Specification



Type	Rated transformation ratio(V)	Accuracy class and rated output COSØ=0.8				1s thermal current(kA)	Rated dynamic current(kA)	Weight (kg)
		0.2S	0.5S	0.5	0.5			
	2.5-400/5	2×10	2×10	2×10(15)	2×10(20)	60I IN	150I IN	
JLS-6	Rated transformation ratio(V)	Accuracy class and rated output COSØ=0.8				Thermal limiting output(VA)		
JLS-10		0.2	0.5	1				
JLS-35	6000/100	2×20	2×30	2×50		300	95	
	10000/100	2×30	2×50	2×80				
	35000/100	2×30	2×50	2×80		400	320	

Note: the date that it's parentheses is volume increase JLS-35 type product

3. Outline and Mounting Dimension

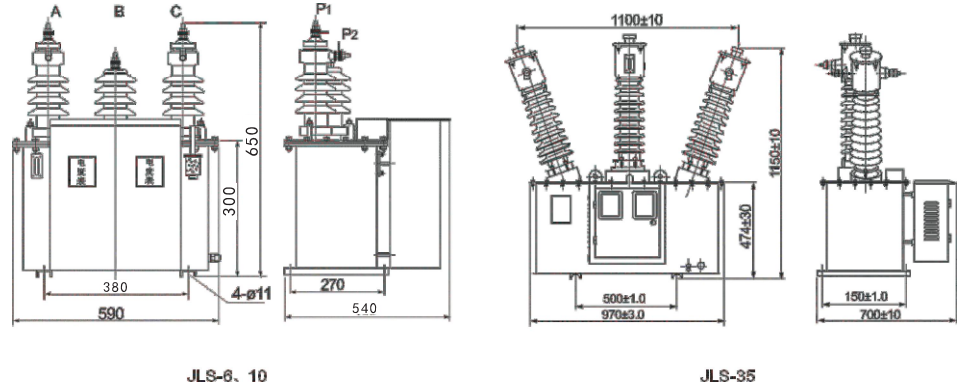

JLS4-6,10,35 Type Outdoor Combined Transformer



1. Type and Meaning

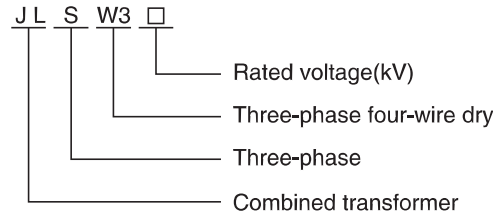

2. Specification

Type	Rated transformation ratio(V)	Accuracy class and rated output COSØ=0.8				1s thermal current(kA)	Rated dynamic current(kA)	Weight (kg)
		0.2S	0.5S	0.2	0.5			
JLS4-6	2.5-400/5	3×10	3×10	3×10(15)	3×10(20)	60I IN	150I IN	
JLS4-10	Rated transformation ratio(V)	Accuracy class and rated output COSØ=0.8				Thermal limiting output(VA)		
		0.2	0.5	1				
JLS4-35	6000/100	3×20	3×30	3×50		300	95	
	10000/100							
	35000/100	3×30	3×50	3×80		400	320	

Note: any special requirements can be negotiated with us

3. Outline and Mounting Dimension

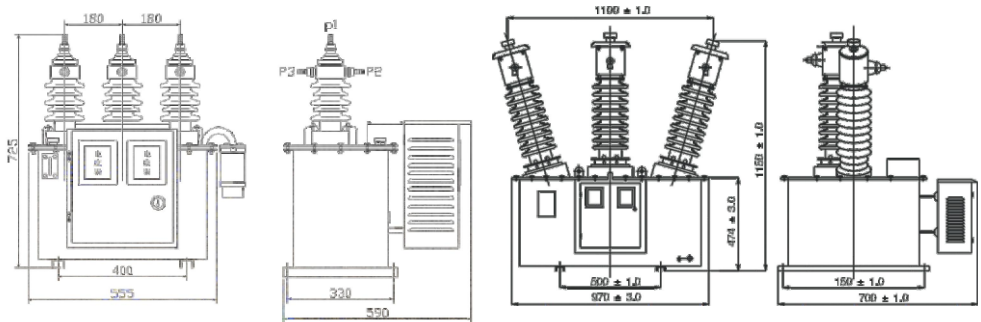

JLS4-10

JLS4-35

JLSZV-6,10(W) Type Outdoor Combined Transformer

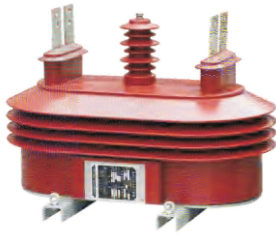

1. Type and Meaning

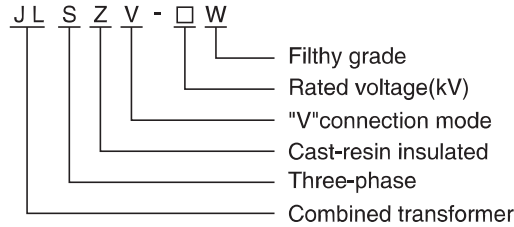

2. Specification

Type	Rated transformation ratio(V)	Accuracy class and rated output COS ϕ =0.8				1s thermal current(kA)	Rated dynamic current(kA)	Weight (kg)
		0.2S	0.2	0.5S	0.5			
JLSZV-6W	5-15/5	10	10	10	15	120I In	300I In	126
	20-75/5					100I In	250I In	
	100-200/5					34	85	
	300-600/5					65	163	
JLSZV-10W	Rated transformation ratio(V)	Accuracy class and rated output COS ϕ =0.8			Thermal limiting output(VA)	300		
		0.2	0.5	1				
	6000/100	20	30	50				
	10000/100							

Note: any special requirements can be negotiated with us

3. Outline and Mounting Dimension

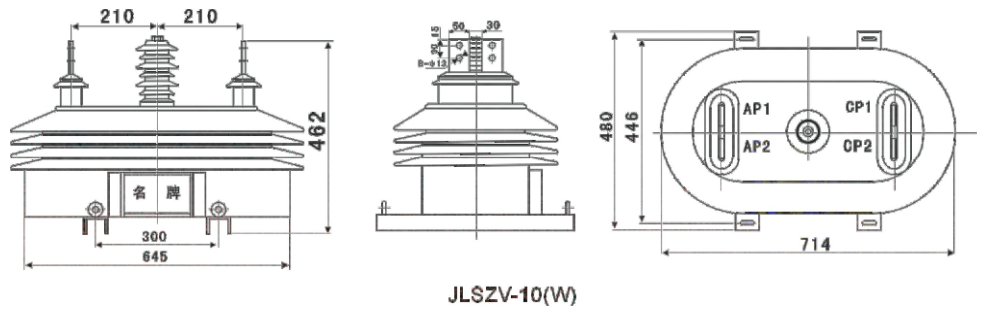

JDZ12A-6,10R Type Voltage Transformer



1. Type and Meaning

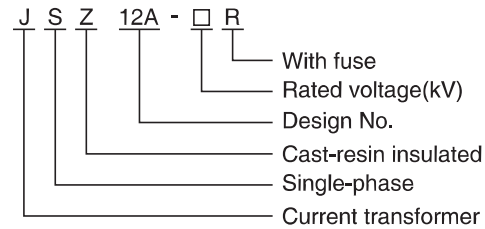

2. Specification

Type	Rated transformation ratio(V)	Accuracy class and rated output COS ϕ =0.8						Thermal limiting output(VA)	Rated insulation level(kV)	
		0.2	0.5	1	3	0.2/0.2 0.2/0.5	0.5/0.5			
JDZ12A-6R	6000/100	30	80	150	240	/	/	500	7.2/32/60	
	10000/100								12/24/75	
JDZ12A-10R	10000/100/100	/	/	/	/	25/25	60/60	600	12/24/75	
	10000/100/220	100	30	80	150	240	/			800
	10000/220/100	220	/	100	150	300	/			
	10000/220/220	220	/	100	150	300	/			

Note: any special requirements can be negotiated with us.

3. Outline and Mounting Dimension

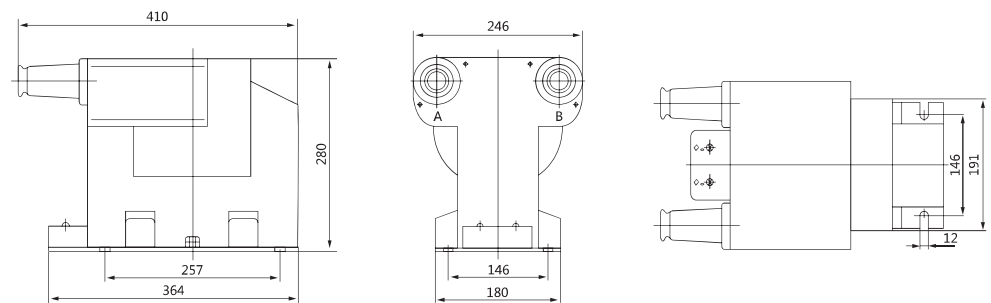

JSZV12A-3,6,10R Type Voltage Transformer



1. Type and Meaning

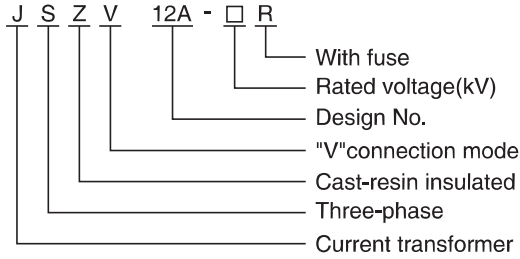

2. Specification

Type	Rated transformation ratio(V)	Accuracy class and rated output COSφ=0.8					Thermal limiting output(VA)	Rated insulation level(kV)
		0.2	0.5	1	3	0.2/0.5		
JSZV12A-3R	3000/100/100	15	30	100	150	20/40	240	3.6/25/40
JSZV12A-6R	6000/100/100	15	30	100	150	20/40	240	7.2/32/60
JSZV12A-10R	10000/100/100	15	30	100	150	20/40	300	12/42/75
	10000/100/220	100	15	30	100	150	300	
		220	/	80	150	240	500	

Note: any special requirements can be negotiated with us.

3. Outline and Mounting Dimension

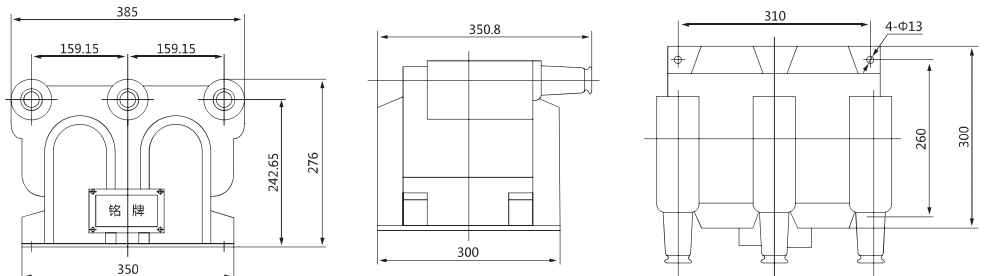

JSZV12-10R



MT88



KT55



FQA900



MT87



MT89



VC3266L



DT303



DM6266



2017



MT7015



KT202B



DT266



DT9250



DT9258FC+



GT201



MT361



KT-3288



UA200



UA3268A



DT2800



EM3213



MT6130



DT9205A+



MT8891



JT8500



MT666



MT77



A9988



DT9205(1)



DT9205(2)



DY2101



DYXB886



DT830B



M3800



KT33B



DT9910

Digital Insulation Resistance Tester



DT2234A*



DT2235B*



DT2236B

Digital Multi Meter



DY5103A



DY30-2



DY30-1

Digital Thermo Meter



TM-902C



DM6801A

Analogue Clamp Meter



MG27B



MG28

Analogue Multi Meter



YX360TRN



8801

Earth Resistance Tester



DY4102



ZC29B



MTN40



FY54



HTC-1



TS80



DY4100



LX1010B



DY207C



MD812



8030



CA310

Resistance tester



ZC11D-10



ZC7



ZC8



1010T

Temperature Controller



REX-C100



REX-C700



TDK 0302



AM72-4BIC
(PO-010)



AM72-8001
(PO-019)



AM96-92001
(IN-050)



CD701



CH402



AM72-2211
(IN-037)



AM72-2001
(IN-038)



AM72-93301
(IN-039)



AM72-92001
(IN-040)



AM4896-93301
(IN-042)



AM4896-90001
(IN-052)



AM48-93301
(IN-049)



ESC4



AM-800
(IN-053)



AM4896-3301
(PO-08)



AM48-4001
(PO-024)



AM-TDA
(PO-026)



AM-TDB
(PO-027)

Temperature Controller



TC-1
(PO-03)



TC-2
(PO-04)



TC-3
(PO-05)



JTC-902
(PO-06)



JTC-903
(PO-07)



JTC-905



SC-3
(PO-28)



AM96-3301
(PO-013)



AM96-8301
(PO-014)



AM96-2301
(PO-016)



AM96-2001
(PO-017)



AM96-4001
(PO-018)



XMTD-2001



AM96-93301
(IN-028)



AM96-2211
(IN-030)



AM96-2001
(IN-031)

Thermocouple and Thermal Resistance

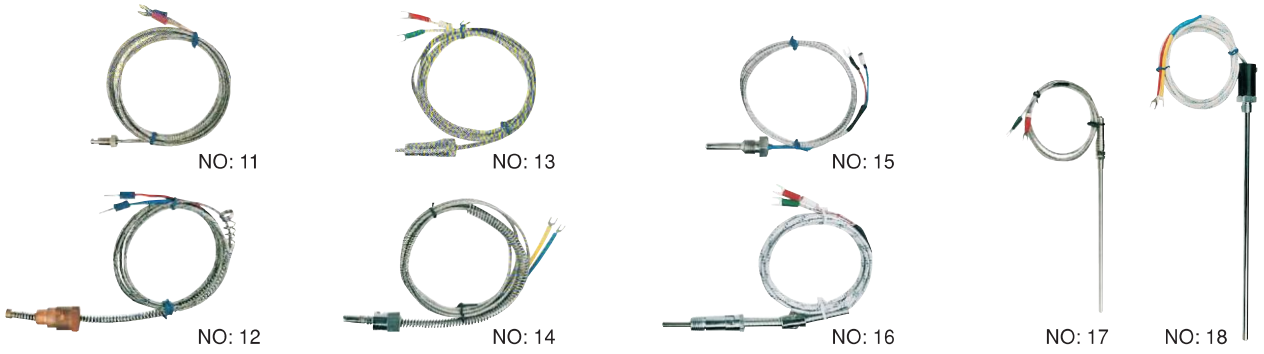
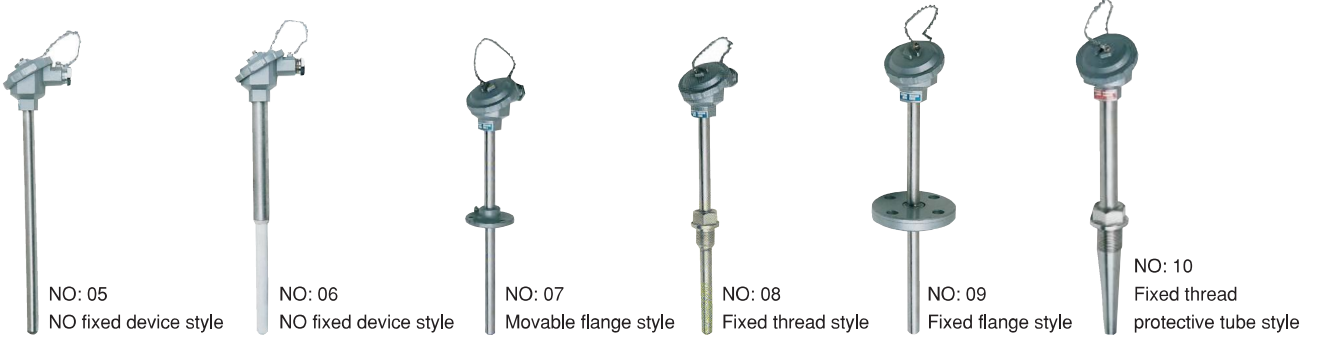



PTC Heater 15-150W HG140

- Compact heater in PTC technology
- Maintains minimum operating temperatures in enclosures
- Helps to prevent failure of electronic components caused by condensation and corrosion
- Heating power adjusts to ambient temperature
- Push connectors for quick and easy wiring
- DIN rail mountable
- CE

Technical Data HG140

Operating voltage	AC/DC 110-250V(also available in 12-48VDC)
Heating element	PTC resistor, self-regulating
Heating body	Anodized extruded aluminum
Protection class	I, test voltage 1600V
Protection type	IP20
Connection	Push-type terminals for stranded and solid wire 3 x AWG 20-16 (0.5-1.5mm ²)
Mounting	Coli for 35mm DIN rail(EN 50022)

Applications

- Electrical & Electronic enclosures
- Telecommunications systems
- Display panels
- Automatic teller machines(ATM'S)
- Access & Parking control systems
- Ticket dispensers

Part.No.	Power ¹⁾	Max.Current ²⁾	L	Weight
14000.0-00	15W	1.5A	2.6"/65mm	0.56 lbs(0.3kg)
14001.0-00	30W	3.0A	2.6"/65mm	0.66 lbs(0.3kg)
14003.0-00	45W	3.5A	2.6"/65mm	0.66 lbs(0.3kg)
14005.0-00	60W	2.5A	5.5"/140mm	1.10 lbs(0.5kg)
14006.0-00	75W	4.0A	5.5"/140mm	1.10 lbs(0.5kg)
14007.0-00	100W	4.5A	5.5"/140mm	1.10 lbs(0.5kg)
14008.0-00	150W	9.0A	8.7"/220mm	1.76 lbs(0.8kg)

Determining the required heater size

$$P_H = (A \times \Delta T \times K) - P_V$$

P_H =Required heating power for your application in Watts(W)
 P_V =Heating power generated by existing components(e.g.a transformer)in Watts(W)

A =Exposed enclosure surface area in square meters(m²)
 ΔT =Temperature differential between the desired minimum interior temperature and the Lowest possible external temperature of the enclosure in Kelvin(K), 1.8°F=1°C=1K
 K= Heat transmission coefficient of the enclosure material used:

- Painted steel: 5.5W/m²K
- Stainless steel: 3.7W/m²K
- Aluminum: 1.2W/m²K
- Polyester/Plastic: 3.5W/m²K

For outdoor applications it is recommended to double the heating power

¹⁾ at 68°F(20°C) ambient temperature

²⁾Inrush current

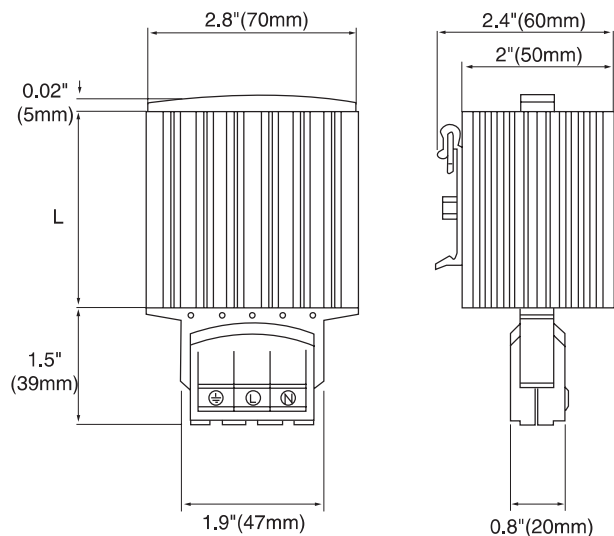

Specifications are subject to change without notice. Suitability of this product for its intended use and any associated risks must be determined by the end customer/buyer in its final application.



Applications

- Electrical & Electronic enclosures
- Telecommunications systems
- Display panels
- Personnel booths
- Automatic teller machines(ATM'S)
- Access & Parking control systems
- Ticket dispensers

Determining the required heater size

$$P_H = (A \times \Delta T \times K) - P_V$$

P_H =Required heating power for your application in Watts(W)

P_V =Heating power generated by existing components(e.g.a transformer)in Watts(W)

A =Exposed enclosure surface area in square meters(m²)

ΔT =Temperature differential between the desired minimum interior temperature and the Lowest possible external temperature of the enclosure in Kelvin(K), 1.8°F=1°C=1K

K= Heat transmission coefficient of the enclosure material used:

- Painted steel: 5.5W/m²K
- Stainless steel: 3.7W/m²K
- Aluminum: 1.2W/m²K
- Polyester/Plastic: 3.5W/m²K

For outdoor applications it is recommended to double the heating power

Small PTC Heater

- Compact heater in PTC technology
- Maintains minimum operating temperatures in enclosures
- Helps to prevent failure of electronic components caused by condensation and corrosion
- Heating power adjusts to ambient temperature
- DIN rail mountable
- CE

Technical Data HGK047

Voltage/heating power	See table
Heating element	PTC resistor, self regulating
Heat sink	Anodized extruded aluminum
Protection class	1(grounded)
Protection type	IP54
Connection	3xAWG30(0.5mm ²),12"(300mm)length
Mounting	Clip for 35mm DIN rail (EN50022)

Part.No.	Voltage	Power ¹⁾	Max.Amps ²⁾	Length	VDE	UL
04700.0-00	140-250 VAC	10W	1.0A	2.0"(50mm)	●	
04701.0-00	140-250 VAC	20W	2.5A	2.4"(60mm)	●	
04702.0-00	140-250 VAC	30W	3.0A	2.8"(70mm)	●	
04700.9-00	110-120 VAC	10W	1.0A	2.0"(50mm)		●
04701.9-00	110-120 VAC	20W	1.5A	2.8"(70mm)		●
047029-00	110-120 VAC	30W	1.5A	4.0"(100mm)		●

¹⁾ at 68°F(20°C) ambient temperature.

²⁾Inrush

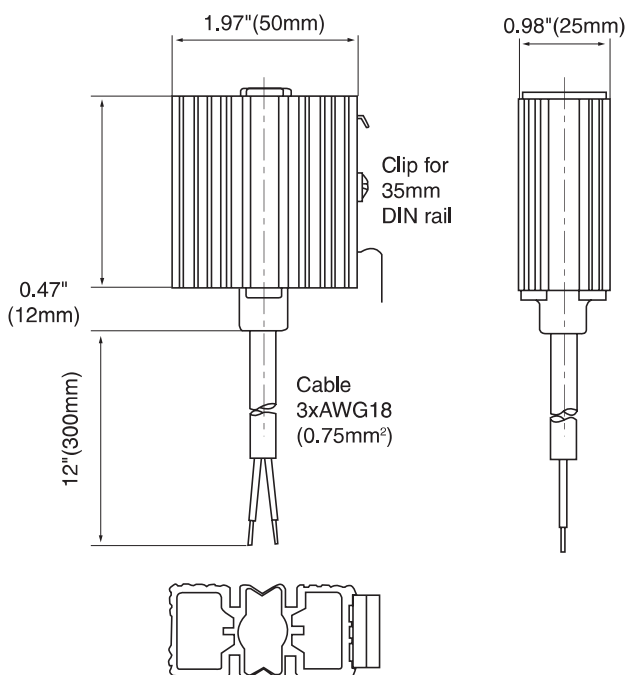

Specifications are subject to change without notice. Suitability of this product for its intended use and any associated risks must be determined by the end customer/buyer in its final application.



Small Thermostat KT011

- Compact design
- Wide adjustment range
- Available with °F or °C scale
- Color coded temperature dials
- DIN rail mountable

Thermostat “NC” (normally closed):
Thermostat opens at temperature rise.
Comes with a red temperature dial.

Thermostat “NO” (normally open):
Thermostat closes at temperature rise.
Comes with a blue temperature dial.

Technical Data KT011

Part.No.	Contact type	Scale on housing
01140.9-00	normally closed	30-140°F
01141.9-00	normally open	30-140°F
01146.9-00	normally closed	0-60°C
01147.9-00	normally open	0-60°C

Sensor element:	Thermostatic bi-metal
Maximum tolerance:	± 7.2°F(4K)
Switching difference(hysteresis):	12.6°F ± 5.4°F(7°C ± 3K)
Service life:	100.000 cycles
Switching capacity(max.load):	15A resistive/2A inductive @ 120 VAC 10A resistive/2A inductive @ 250 VAC DC 30W
EM/EMC compliance:	EN55014-1-2,EN16000-3-2,EN61000-3-3
Connections:	2-pole terminal for AWG 14 max.(2.5mm ²)
Mounting:	Clip for 35mm DIN rail(EN50022)
Dimensions(H x W x D):	2.4 x 1.3 x 1.7”(60 x 33 x 43mm)
Housing material	Plastic
Protection type:	IP20
Operating temperature:	-4 to 176°F(-20 to 80°C)

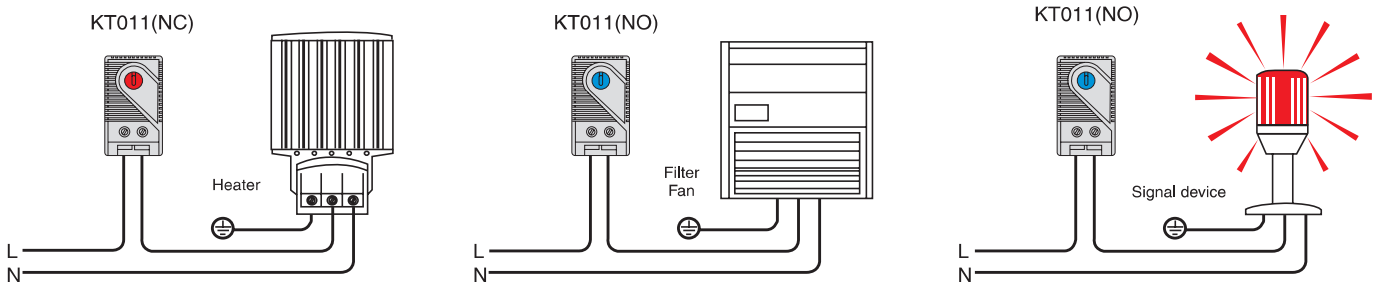
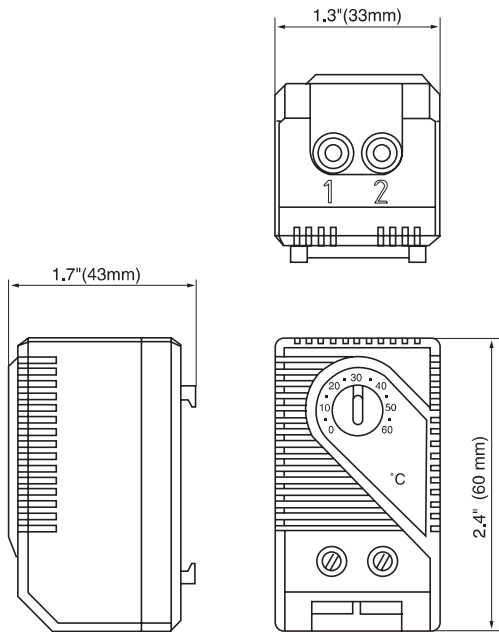

Wiring examples