

TD-501

DOPPLER SPEED LOG

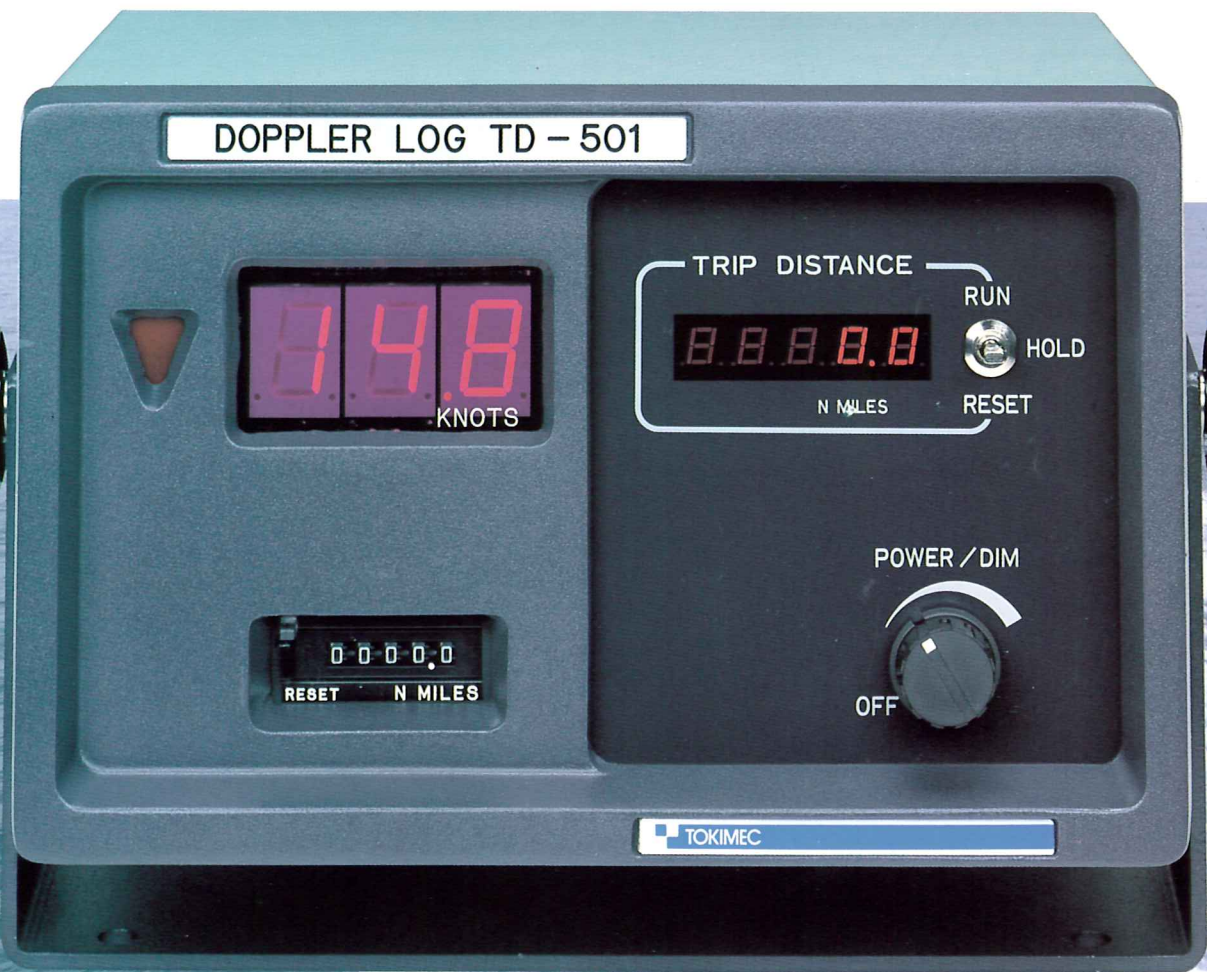

A high-accuracy log that's easy to rig and simple to operate.

In recent years marine logs have come to serve the dual function of measuring both distance and speed. Many of them are now used to perform the important task of transmitting highly accurate speed signals to ARPA, NNS and autopilots. Moreover, ocean-going vessels of all types and classes will soon be required to sail with a new type of log that satisfies the International Performance Standards for "marine speed and distance measuring equipment" currently being prepared by IMO.

The TD-501 Doppler Speed Log has been specially developed with the foregoing in mind. It is a new type of highly accurate speed log for merchant ships, and was specifically designed and engineered for simplicity of installation and operation. The log's master display unit, employing large LEDs, provides speed and distance data on digital indicators. For additional capacity, optional auxiliary analog or digital displays can be connected.

A series of on-board tests have already verified the TD-501's unparalleled accuracy and reliability, confirming that it will conform fully to the IMO International Performance Standards.

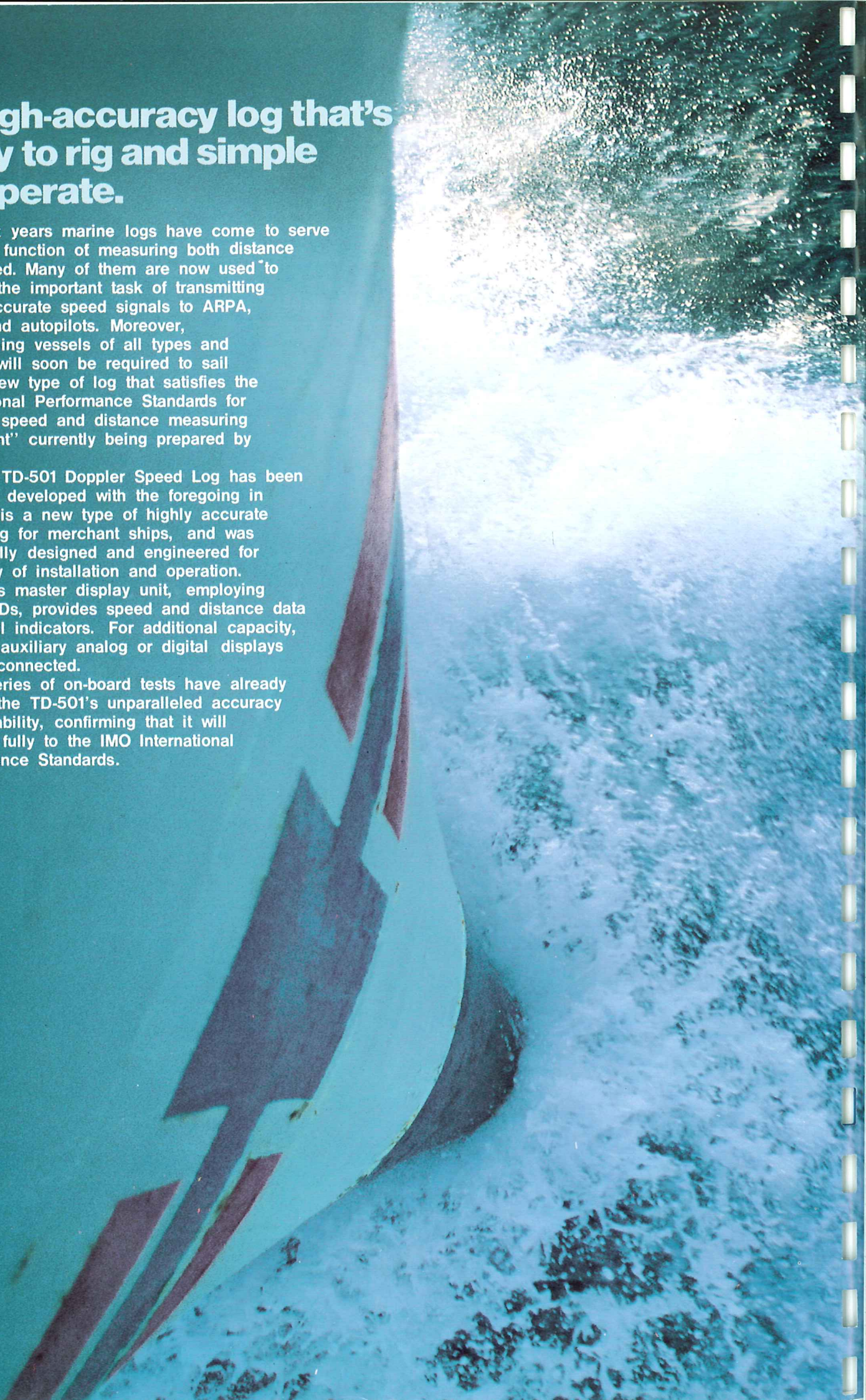

FEATURES

High-accuracy measurement of ship's speed with respect to water

By the use of high-frequency sonic energy (2 MHz) and the pulse system, the TD-501 can receive doppler shifted echoes in any sea area. Furthermore, by receiving the echoes selectively from about 3 m below the ship's hull, the TD-501 eliminates adverse wake influences. Thus the TD-501 fully satisfies the need for measuring the ship's speed accurately with respect to the water beneath the hull.

Virtually free from errors caused by ship's motions

The TD-501 adopts the paired-beam system in which the sonic energy is directed ahead and astern. The ship's speed is obtained by averaging the doppler shifted echoes from ahead and astern. This virtually eliminates doppler shift errors caused by the ship's motions.

No protrusions from ship's hull

By virtue of its non-protruding, flush-mount design, the transducer of the TD-501 is completely free from the danger of fouling or damage caused by drift ice or wood. Moreover, it need not be retracted before entering a port or extended after leaving it.

Master display unit provided with trip distance indicator

The master display unit is provided with two trip distance indicators, one being an electromagnetic counter indicating the total distance covered and the other an LED indicator employing a non-volatile memory. This arrangement makes it possible to read out the trip distance within a given time or between two given points.

Availability of optional auxiliary displays and distance indicators

Any number of digital auxiliary displays and up to three analog auxiliary display units can be installed. The digital auxiliary display unit has two circuits transmitting distance signals at a rate of 200 pulses per mile travelled, together with one distance indicator drive circuit. Accordingly, its outputs can be supplied as input signals to various navigational equipment, together with the output signals from the master display unit.

Low cost and simplicity of installation

All cables required for the TD-501 installation need to satisfy only the relevant JIS requirements, with the exception of the transducer cable which is furnished by TOKIMEC. In addition, the transducer needs no lifting/lowering device owing to its flush-mount design. As a result, the entire TD-501 system can be installed with great ease and at low cost.

Simplicity of operation

The entire TD-501 system can be put in operation simply by depressing the power switch on the master display unit and by adjusting the illumination control device.

COMPOSITION

* indicates option

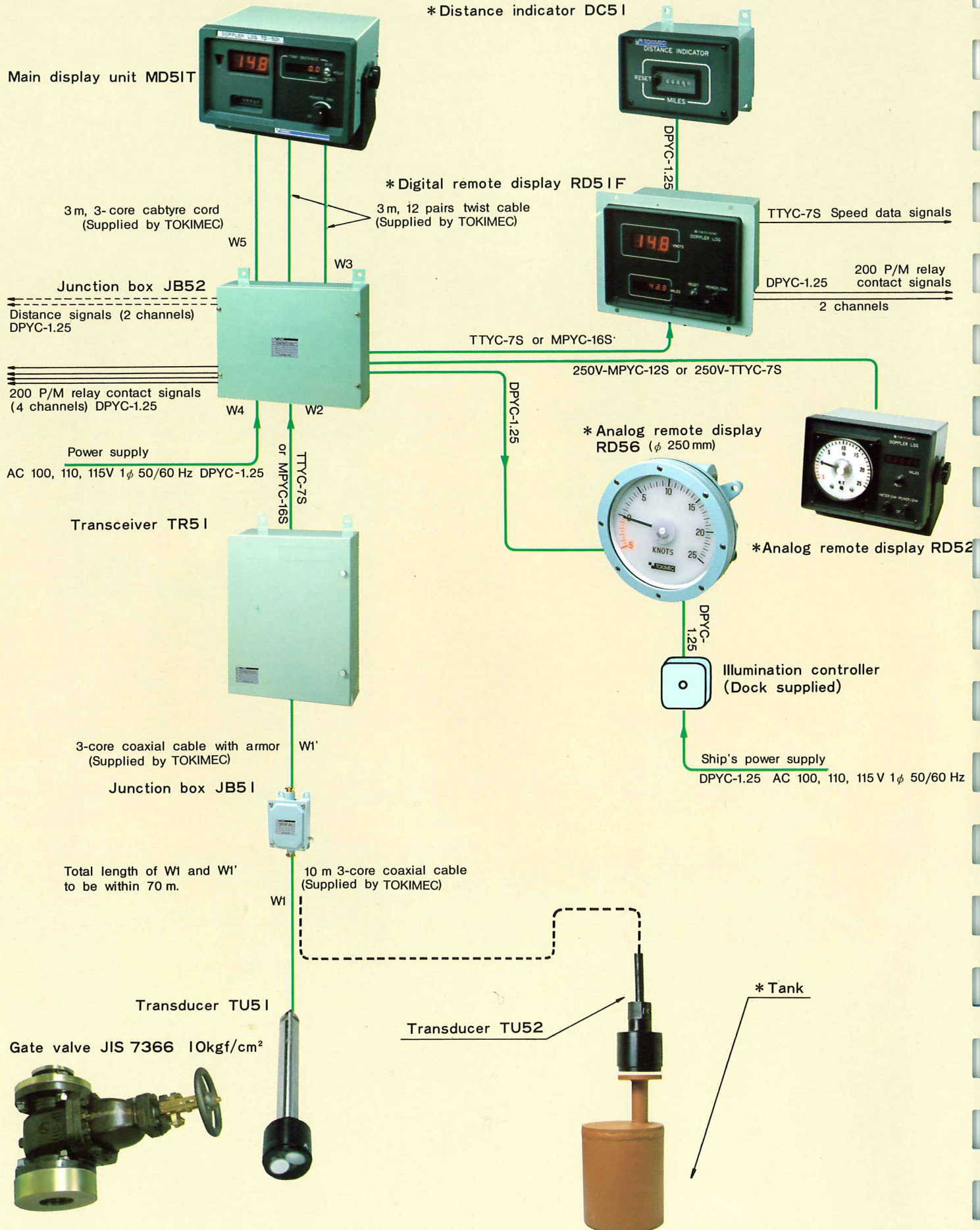

BASIC SPECIFICATIONS

Master Display Unit

Operating mode	Ultrasonic paired-beam pulsed doppler system
Operating frequency	2 MHz
Speed range	-10 ~ +30 knots
Speed display	3-digit numerical LED readout
Advance/retard display	Red LED display for retard
Speed accuracy	±1% ±0.1 knot
Distance display	0.0~9999.9 nautical miles (electromagnetic counter with automatic reset)
Trip distance display	0.0~9999.9 nautical miles (LED using a non-volatile memory)
Measured water depth	3 m (1~4.5m variable)
Speed outputs	16-bit serial BCD and current outputs
Trip distance outputs	200 pulses/mile contact signals (75 ms pulse width) x 4 circuits
Distance signals	10 pulses/mile signal x 2 circuits
Auxiliary display	Digital display (one unit only) or analog display (3 unit only)
Power ratings	AC 100/110/115 V $\pm 15\%$, 1 ϕ 50/60 Hz
Power consumption	Less than 50 VA
Auxiliary functions	i) Self-test circuit ii) Transducer installation error correction circuit iii) Automatic seawater temperature and salinity correction

Distance outputs	200 pulses/mile contact signals (75 ms pulse width) x 2 circuits
Distance signals	10 pulses/mile signals x 1 distance indicator drive circuit
Auxiliary display connections	One unit only of digital display (or 16-bit serial BCD data signals)
Power supply control	Main display (system) power supply controllable by means of power switch of this auxiliary display
Power ratings	AC 100/110/115 V $\pm 15\%$, 1 ϕ 50/60 Hz
Power consumption	Less than 50 VA

Auxiliary Display Unit (Analog)

Speed display	Analog meter display in 0.5 knot increments
Speed range	-5 ~ +25 knots (standard) or -4 ~ +30 knots (special order)
Auxiliary display connections	One analog display only
Power supply and ratings	Power ratings (for illumination): AC 100/110/115 V $\pm 15\%$, 1 ϕ 50/60 Hz
Power consumption	Less than 10 VA for illumination
Mounting	Wall mounting (housing dimmer) Flush mounting: An illumination controller (JIS F 8852) should be supplied by shipyard

Auxiliary Display Unit (Digital)

The auxiliary display receives speed data signals from the master display unit and indicates the ship's speed.

Speed display	3-digit numerical LED readout
Advance/retard display	Red LED display for retard
Distance display	0.0~9999.9 nautical miles, LED display with automatic

Connection of Auxiliary Display Units

Connection of Analog Displays (A) only

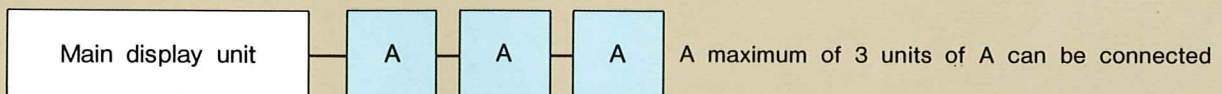

Connection of Digital Displays (D) only

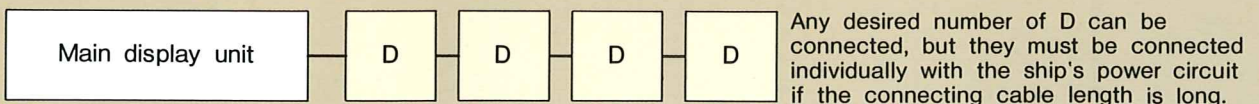

Connection of A and D

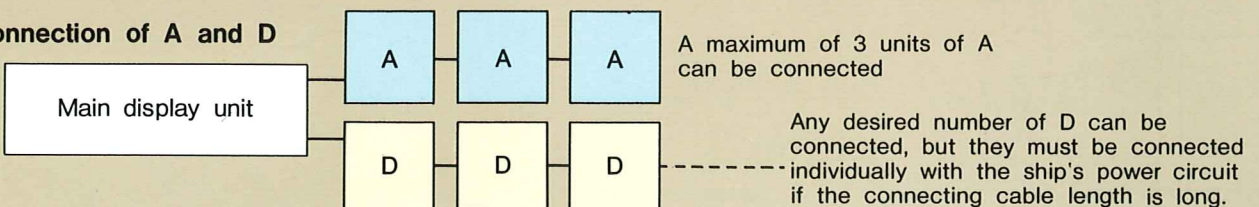

● Main Display Unit

MD 51T (Table type)

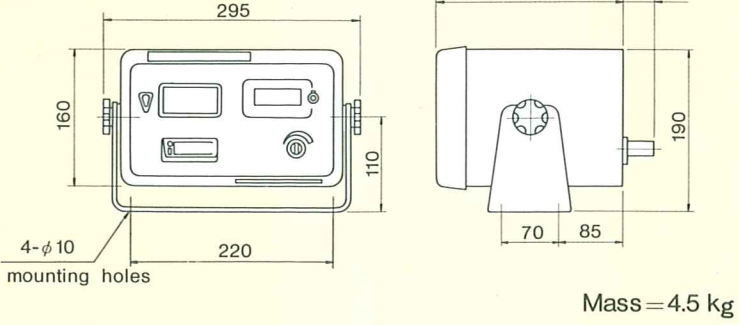

MD 51F (Flush type)

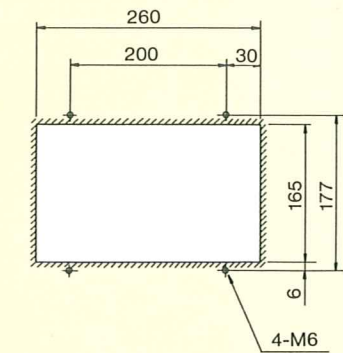
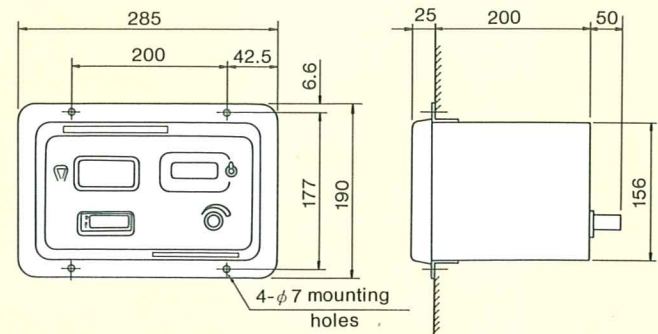

PANEL CUT

Mass=4.5 kg

● Remote Display(Digital)

RD 51F (Flush type)

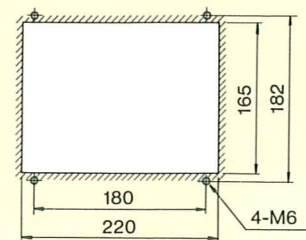
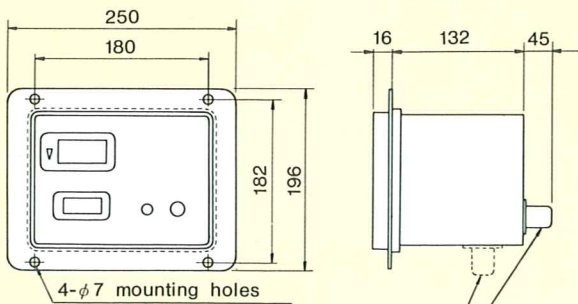

PANEL CUT

Mass=4.5 kg

Connectors
(mounting position
may be selected)

RD 51T (Table type)

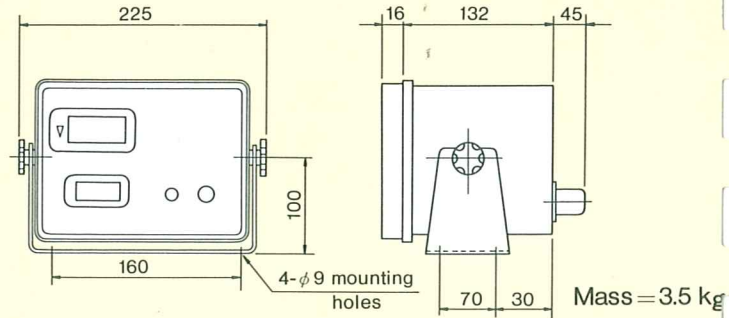

● Remote Display(Analog)

RD 56 (Wall mounting type)

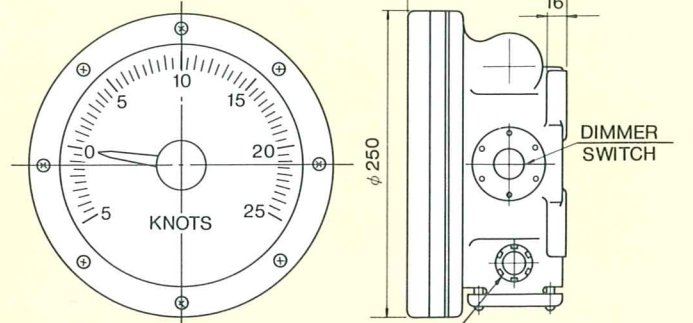

FOR ILLUMINATION SOURCE
AND AMPERE-METER

Mass=5 kg

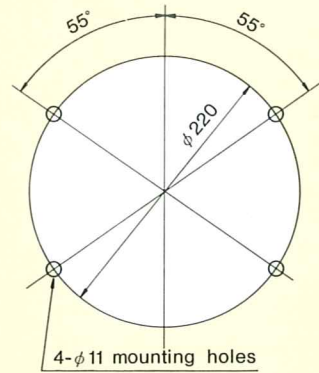

RD 55 (Flush type)

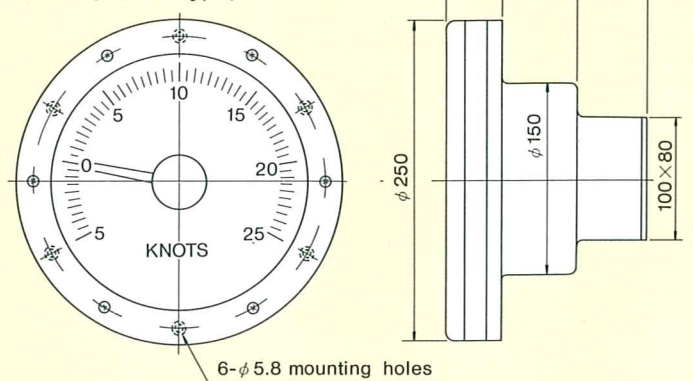

Mass=3.9 kg

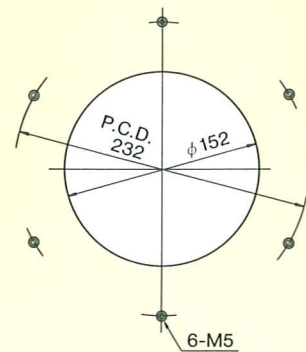

RD 52T (Table type)

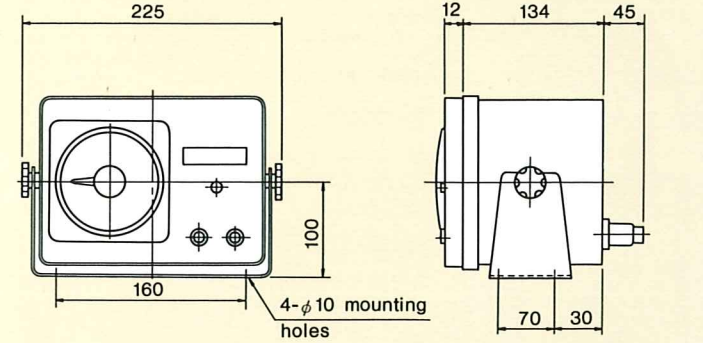

RD 52F (Flush type)

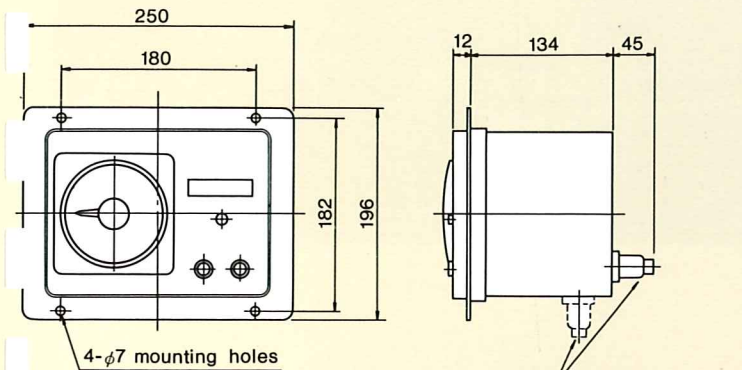

Mass=4.5 kg

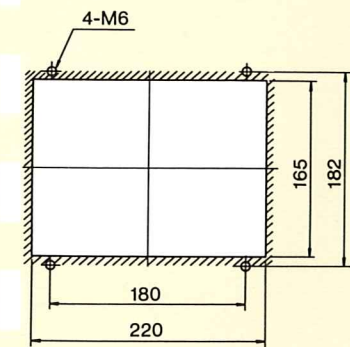

RD 57 (Flush type)

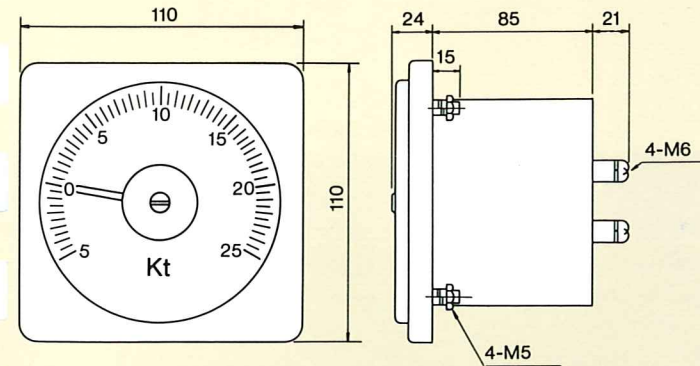

Mass=0.9 kg

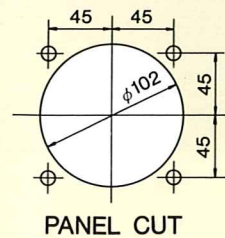

PANEL CUT

● Distance Indicator

TR 51

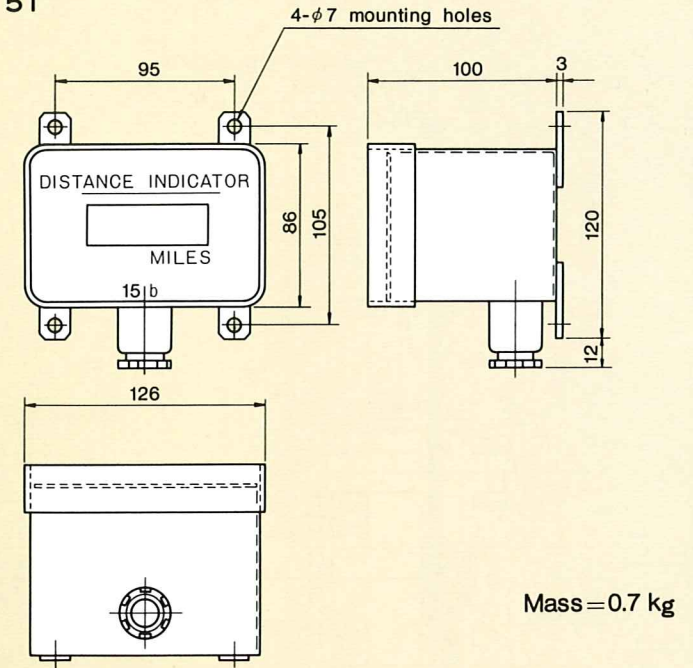

Mass=0.7 kg

● Junction Box

For transceiver unit JB 51

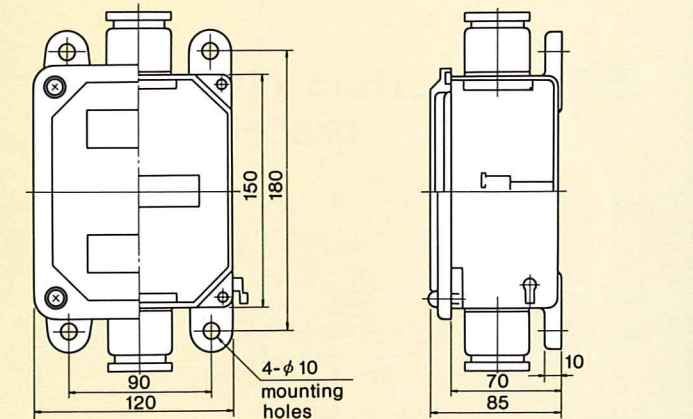

Mass=1.5 kg

For display unit JB 52

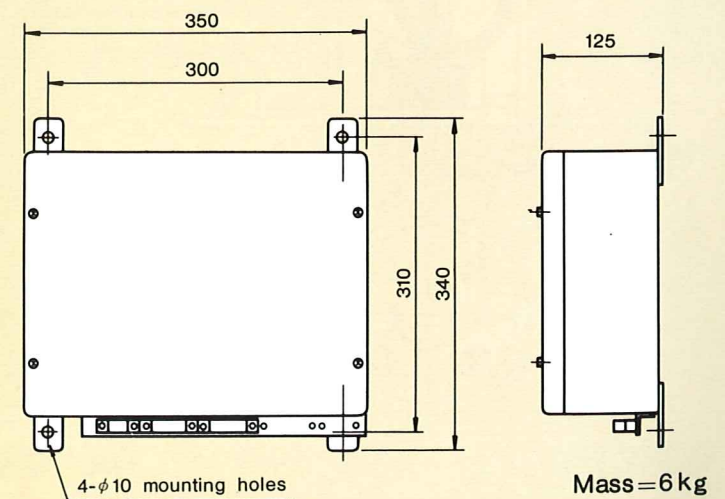

Mass=6 kg

● Transducer

Sluice valve type
TU 51

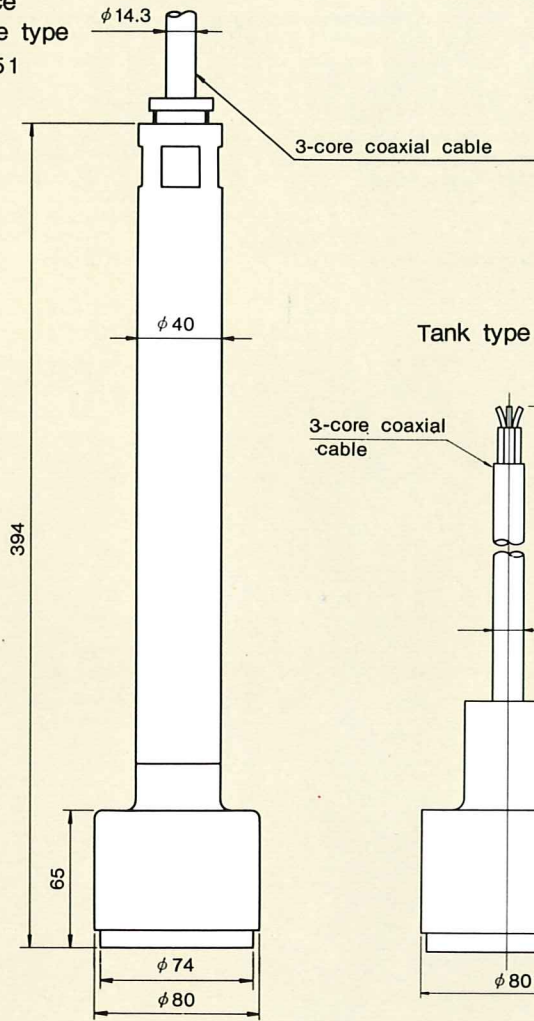

Mass=10 kg (with cable)

Tank type TU 52

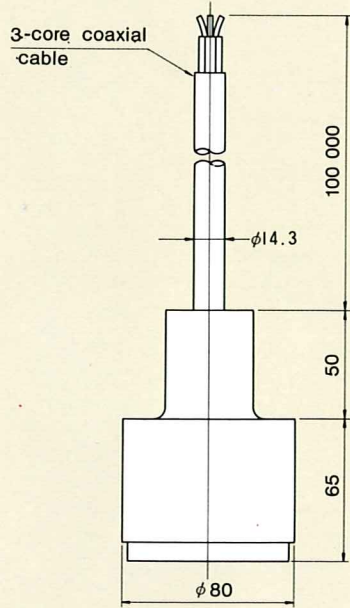

Mass=8.5 kg (with cable)

● Transceiver

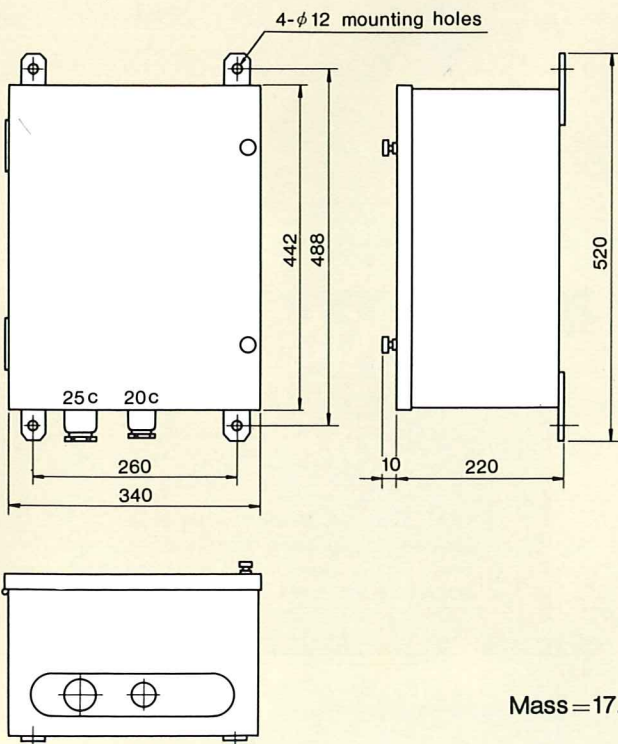

Mass=17.5 kg

● Gate Valve

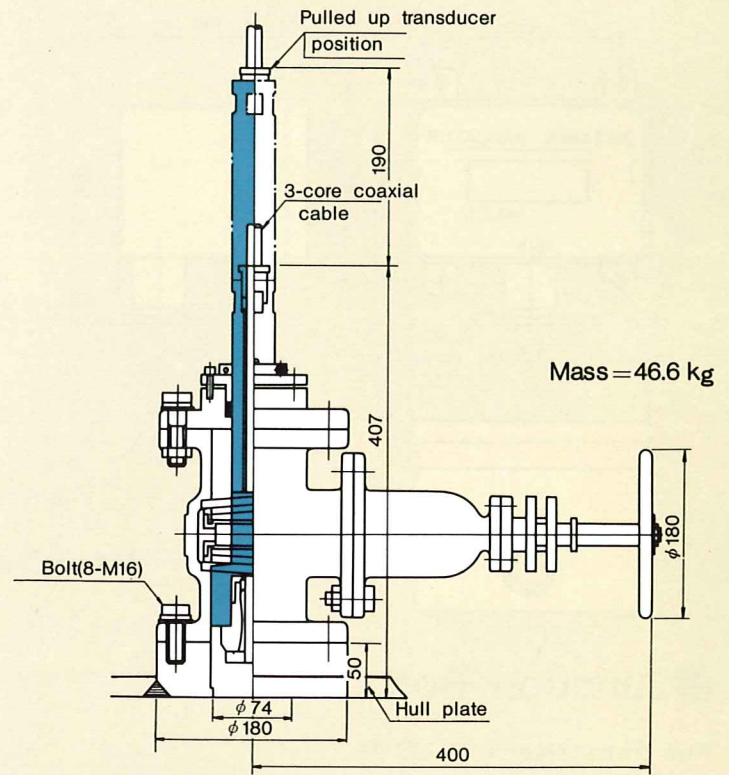

● Tank (Bottom plate bracket type)

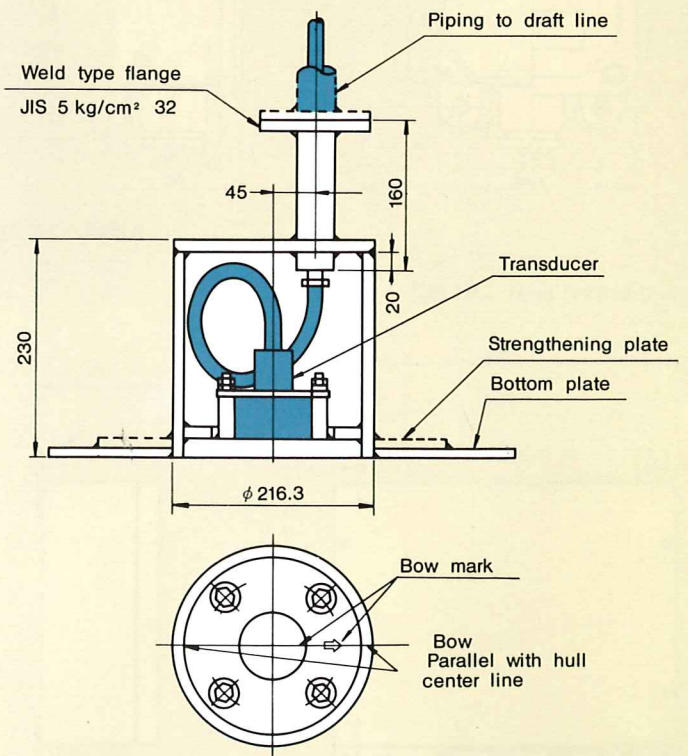

Mass=27 kg

Worldwide service network



You are assured of complete and efficient servicing by the TOKIMEC service network, which covers the entire world and is staffed by well-trained service technicians.

Specifications are subject to change without notice.

TOKIMEC

TOKIMEC INC.

CONTROL SYSTEMS DIVISION

Head Office: 2-16-46, Minami-Kamata, Ota-ku, Tokyo 144, Japan
Tel: (03) 3737-8611 Fax: (03) 3737-8663

TOKIMEC EUROPE B.V.: Beurs-World Trade Center, Room 410-411
Beursplein 37, P.O.BOX 30210, 3001 DE Rotterdam, The Netherlands
Tel: 10-4051260 Fax: 10-4055042