

FURUNO®

Revolutionary heading sensor with advanced GPS technology

SATELLITE COMPASS

Model SC-50



Radome Antenna

Open Antenna



® The future today with FURUNO's electronics technology.

FURUNO ELECTRIC CO., LTD.

9-52 Ashihara-cho, Nishinomiya City, Japan Phone: +81 (0)798 65-2111

Fax: +81 (0)798 65-4200, 66-4622 URL: www.furuno.co.jp

Catalogue No. N-857b

TRADE MARK REGISTERED
MARCA REGISTRADA

FURUNO's advanced GPS technology ensures highly accurate heading data for AIS, ECDIS, ARPA Radar, Autopilots and more.



Compass Rose Mode

- Heading accuracy $\pm 1.0^\circ$ complying with IMO MSC.116(73) as a THD (Transmitting Heading Device)
- Excellent follow-up rate of $45^\circ/\text{s}$ exceeding requirements for high speed craft ($20^\circ/\text{s}$)
- Pitch and roll output in both analog and digital formats for ship's motion correction for the FCV-30 and CH-250/270/300
- Tri-antenna system reduces the effect of pitching, rolling and yawing
- Free from regular maintenance
- Accurate SOG, COG, ROT, and L/L
- High speed heading data output in IEC 61162-2 format (38.4 kbps)
- Output in IEC 61162-1/2 or FURUNO AD-10 formats is available:
up to 10 ports in IEC 61162-1/2 or up to 5 ports in AD-10 or combination of IEC 61162-1/2 and AD-10 formats
- Individual setting of output sentences and baud rate in each port for flexible interface with external equipment
- Clear 4.5" silver bright LCD

The SC-50 is a satellite compass that uses FURUNO's advanced GPS technology. The satellite compass can be used for a wide range of applications for any type of vessel. Radar/ARPA, AIS, ECDIS, scanning sonar and Autopilots can utilize the functions of this compass. As the SC-50 uses GPS carrier frequency to determine heading, the performance is not affected by ship's speed, latitude, geomagnetism, etc. Settling time is almost instantaneous and the follow-up performance is excellent, achieving $45^\circ/\text{s}$ (SOLAS HSC Code requires $20^\circ/\text{s}$ as a minimum).

The satellite compass delivers GPS positioning, SOG (Speed Over Ground), COG (Course Over Ground) and ROT (Rate of Turn). SOG accuracy is achieved by decoding the Doppler shift in the received satellite signals. The information can be output in IEC61162-2 format, at the high update rate up to 38.4 kbps to satisfy the high speed data-output requirements in special applications.

The pitch and roll angle is output both in analog and digital formats to external equipment. For sonar or fish finders, the SC-50 can function as a highly accurate motion sensor through compensating the transmitted/received beams affected by pitch/roll. This results in the

presentation of stable echo pictures even in rough seas.

The SC-50 has a unique Set and Drift mode. In this mode set and drift (tide direction and speed) are calculated by connecting with a water-tracking speed log, such as the DS-80. This display mode helps a radar operator get accurate sea stabilized pictures by manually entering set and drift.

The SC-50 consists of antenna, display and processor units. The antenna is selectable from an open antenna featuring good performance under snowfall or a stylish Radome antenna. Each accommodates three GPS antennas.

The tri-antenna system helps reduce the influence of vessels' motions rather than dual-antenna system.



Processor Unit



Steering Mode



NAV Data Mode



Heading Mode



ROT Mode

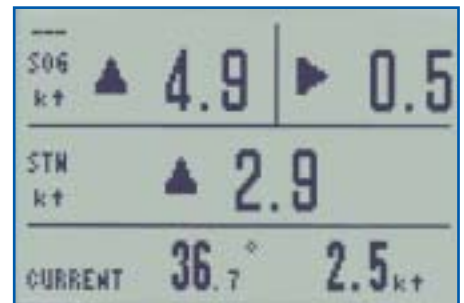

Set & Drift Mode

(Current (Set and Drift) and Distance Run is selectable.)

Principle

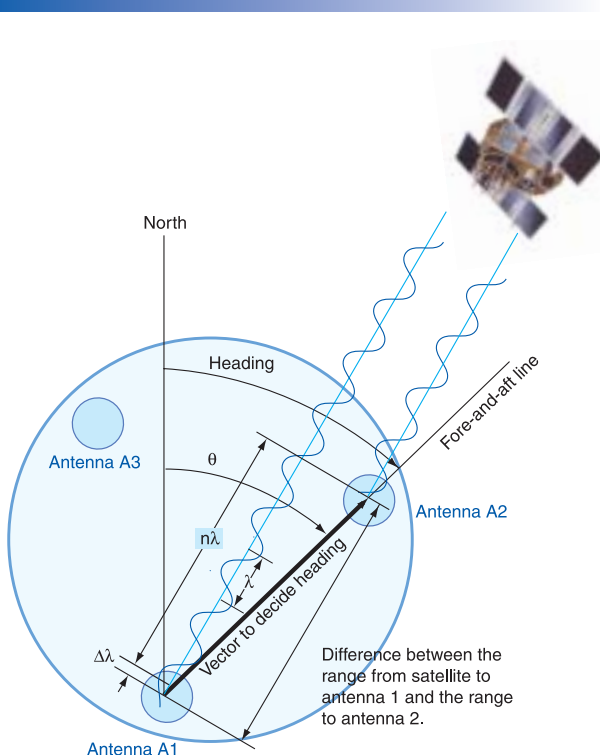

With the SC-50, a ship's heading is determined by decoding the phase data in the GPS carrier frequency. In principle, a pair of antennas A1(ref) and A2(fore), each connected with an associated GPS engine and processor, are installed along the ship's fore-aft line. The GPS systems at A1 and A2 calculate the range and azimuth to the satellite.

The difference in range between A1 and A2 is $\Delta\lambda + n\lambda$ where λ is 19 cm and n^* is automatically found during the initialization stage. A fraction of a carrier wavelength, $\Delta\lambda$, is processed by Furuno's advanced kinematic technology in geographical survey, thus determining a vector (range and orientation) A1 to A2, i.e., heading of ship relative to north.

In reality, the third antenna is added to reduce the influence of pitch, roll and yaw, and five satellites are used to process 3D data (by 3rd sat), to reduce clock derived error (by 4th sat), and to calculate n in initial stage (by 5th sat).

If the GPS signal is blocked by a tall building or under a bridge, the 3-axis vibrating-gyro rate sensors in the processor unit take the place of the satellite until all five satellites are in view. The rate sensors also contribute to regulating the heading data against pitch, roll and yaw together with the third antenna (A3 in the illustration).

*Ambiguity "n" is resolved by LAMBDA algorithm developed by Prof. Teussen, Delft University of Technology, The Netherlands.

SPECIFICATIONS OF SC-50

1. Accuracy

Heading	±1.0° (95% static accuracy)
GPS Fix	10 m (95%)
DGPS Fix	5 m (95%)
WAAS Fix	3 m (95%)

2. Follow-up

45°/s rate-of-turn

3. Settling time

3 min

4. Interface

Number of ports	5 ports in AD-10 or 10 ports in IEC 61162-1/-2
10 ports*	* can be utilized in menu selection
1 port	AD-10 only

Serial data sentence

25, 100, 200 ms, 1, 2 s data rate:
HDT, HDM(Heading), ROT(Rate of turn)
ATT(Pitch and Roll)

1, 2 s data rate:
VHW(Heading), VTG, VBW(SOG),
GGA, GLL, GNS(L/L), ZDA(UTC),
VDR(Set and Drift)

Log output	1 port: 200/400 p/nm (closure)
Alarm output	1 port: Alarm signal (closure signal)
Heading input	1 port: Backup Heading (AD-10/IEC 61162-1)

HDT, HDG, HDM, VBW, VHW, VLW
1 port: RTCM SC-104 format

5. Receiver Type

Twelve discrete channels.
C/A code, all-in-view

6. Receive Freq

L1 (1575.42 MHz)

7. Display Unit

4.5" Monochrome LCD,
95 (W) x 60 (H)mm, 120 x 64 pixels
Steering, Nav Data, Compass Rose,
ROT, Heading and Set and Drift modes

8. Display Mode

POWER SUPPLY

12-24 VDC, 15 W

ENVIRONMENTAL

IEC 60945 for EMC, Vibration, Temperature

EQUIPMENT LIST

Standard

- | | |
|--|--------|
| 1. Display Unit SC-502 | 1 unit |
| 2. Antenna Unit SC-303 or SC-603 with 15 m cable | 1 unit |
| 3. Processor Unit SC-501 | 1 unit |

Option

- | |
|--|
| 1. Antenna Cable, 30 m CP20-01700, 50 m CP20-01710 |
| 2. Flush Mount Kit S type CP20-17, F type CP20-29 |

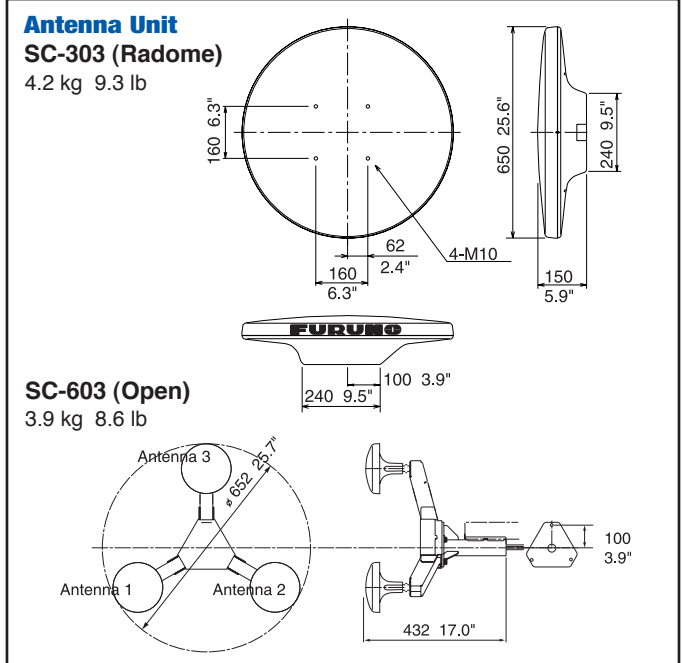
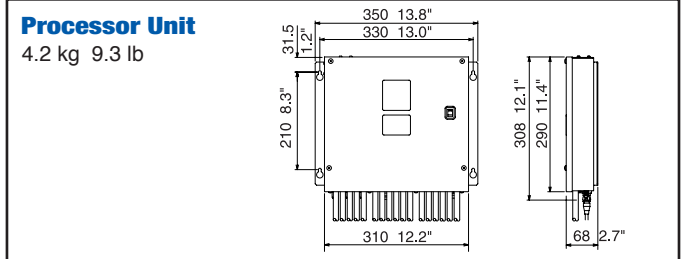
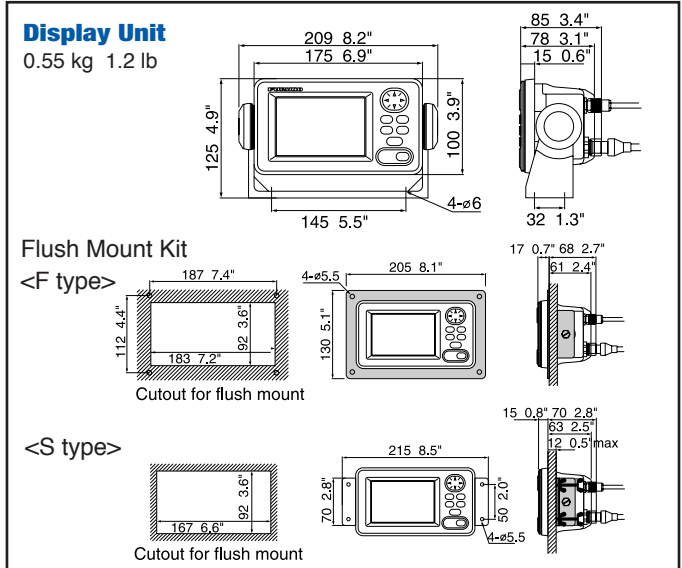

SPECIFICATIONS SUBJECT TO CHANGE WITHOUT NOTICE

Interconnection Diagram

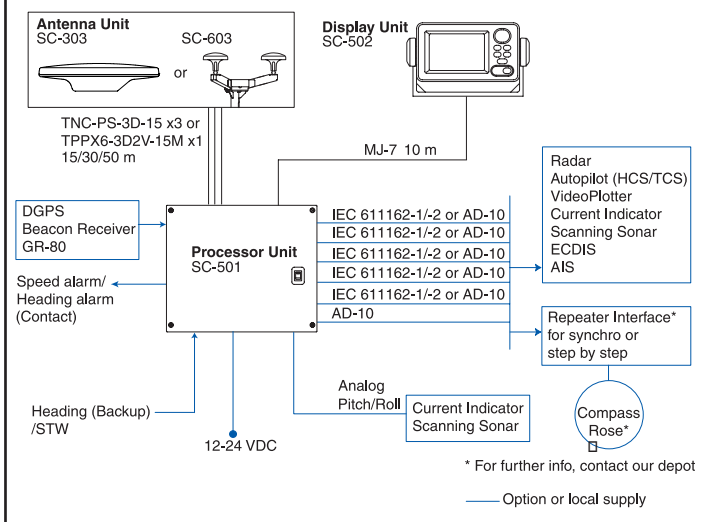

* For further info, contact our depot

— Option or local supply

FURUNO U.S.A., INC.
Camas, Washington, U.S.A.
Phone: +1 360-834-9300
Fax: +1 360-834-9400

FURUNO (UK) LIMITED
Denmead, Hampshire, U.K.
Phone: +44 2392-230303
Fax: +44 2392-230101

FURUNO FRANCE S.A.
Bordeaux-Mérignac, France
Phone: +33 5 56 13 48 00
Fax: +33 5 56 13 48 01

FURUNO ESPAÑA S.A.
Madrid, Spain
Phone: +34 91-725-90-88
Fax: +34 91-725-98-97

FURUNO DANMARK AS
Hvidovre, Denmark
Phone: +45 36 77 45 00
Fax: +45 36 77 45 01

FURUNO NORGE A/S
Ålesund, Norway
Phone: +47 70 102950
Fax: +47 70 127021

FURUNO SVERIGE AB
Västra Frölunda, Sweden
Phone: +46 31-7098940
Fax: +46 31-497093

FURUNO FINLAND OY
Espoo, Finland
Phone: +358 9 4355 670
Fax: +358 9 4355 6710

FURUNO POLSKA Sp. z o.o.
Gdynia, Poland
Phone: +48 58 669 02 20
Fax: +48 58 669 02 21

FURUNO DEUTSCHLAND GmbH
Rellingen, Germany
Phone: +49 4101 838 0
Fax: +49 4101 838 111

FURUNO EURUS LLC
Petersburg, Russia
Phone: +7 812 767 15 92
Fax: +7 812 766 55 52

PRINTED WITH SOY INK 05105SS Printed in Japan

