

FURUNO®

15-INCH MULTI-COLOR HIGH-PERFORMANCE RADAR

Models **FR-1505/1510/1525 MARK-3**

- Daylight-bright 15-inch multi-color, high-resolution display
- Logarithmic amplifier receiver
- 16-level yellow or green display with day and night color palette
- Dual EBLs and VRMs, with floating origin
- Head-Up, Course-Up, North-Up or Head-up True Bearing and True Motion modes
- True or relative echo trails
- Two target alarm zones
- 10-target Electronic Plotting Aid (EPA) with true or relative vectors
- Two user-programmable function keys for one-touch optimized radar setting
- Optional 20-target Auto Plotter ARP-17 (ATA)
- Optional Video Plotter RP-17
- Optional interface board to provide video output for external monitor
- Optional 42 rpm gearbox available



The future today with FURUNO's electronics technology.

FURUNO ELECTRIC CO., LTD.

9-52 Ashihara-cho, Nishinomiya City, Japan Phone: +81 (798) 65-2111
Fax: +81 (798) 65-4200, 66-4622 URL: www.furuno.co.jp

Catalogue No. R-171c

TRADE MARK REGISTERED
MARCA REGISTRADA

Advanced video processing techniques to enhance detection capability on both short and long ranges shown on a 15-inch high-resolution display



6.5 ft antenna
(4 or 8 ft available)

- FR-1505 MARK-3: 6 kW**
- FR-1510 MARK-3: 12 kW**
- FR-1525 MARK-3: 25 kW**

Complies with the following regulations and standards

- IMO Resolutions MSC. 64 (67) Annex 4
- IEC 60936-1 Shipborne radar standard
- IEC 60945 General requirements
- IEC 60872-2 ATA (Optional ARP-17 required)



The FURUNO FR-1505/1510/1525 MARK-3 X-band radars will reinforce Furuno's long established tradition of high performance and reliability. They meet the exacting international and national performance standards for use on ships requiring a radar with the display diameter of 180 mm. The Video Plotter RP-17 is available when Radar Mapping function is also required.

The 1505/1510/1525 MARK-3 employ advanced video processing techniques for improved noise rejection and automatic clutter suppression. They also feature clearly distinguished target trails from real targets by different color tones and accurate plotting, manually or automatically.

Five presentation modes are available: Head-up, Course-up, North-up, Head-up true bearing and True Motion with appropriate heading and speed data in IEC 61162 format.

A wide choice of antenna types is offered to meet the varying needs of individual installations. A high-speed scanner (42 rpm) is optionally available instead of standard 24 rpm.

Standard features include dual VRMs/EBLs where No.1 EBL may be off-centered and has a range marker on it, true/relative target trails, echo stretch, two target alarm zones, trackball for direct range/bearing readout, EPA, quick restart of transmission in case of accidental power-off, etc.

Two target alarm zones can be set in any sector at a desired range. Visual and audible warnings are produced to warn of a target entering the target alarm zone or preset CPA/TCPA zone.

The standard EPA (Electronic Plotting Aid) permits you to plot up to 10 targets. For SOLAS Convention ships, the Auto Plotter ARP-17 (ATA) and Video Plotter RP-17 are optionally available.

Powerful Standard Features

True or Relative Target Trails

Provided with ship's heading and speed data, the FR-1505/1510/1525 MARK-3 present true echo trails which permit intuitive recognition of surrounding situation without smearing of stationary targets, such as land. Relative echo trails are useful for identifying a target on a collision course. The echo trails are displayed in monotone or multilevel shading with a trail length selected between 15 s and 30 min, or continuously.

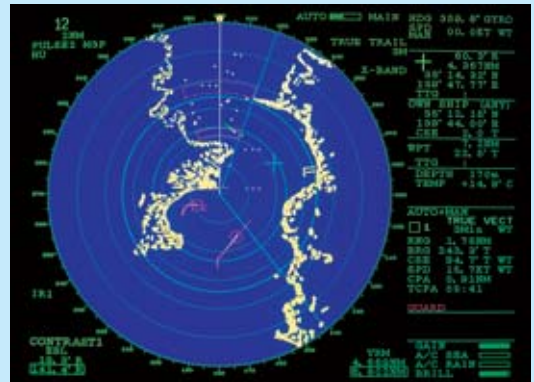

Radar Plotting Facilities

The new IMO Resolution defines 3 types of radar plotting facilities: Electronic Plotting Aid (**EPA**), Automatic Tracking Aid (**ATA**) and Automatic Radar Plotting Aid (**ARPA**). All these Plotting Aids generate CPA and TCPA and

collision alerts, complying with all IMO and IEC standards. The FR-1505/1510/1525 MARK-3 provide EPA and ATA*. *with optional ARP-17

EPA (Electronic Plotting Aid)

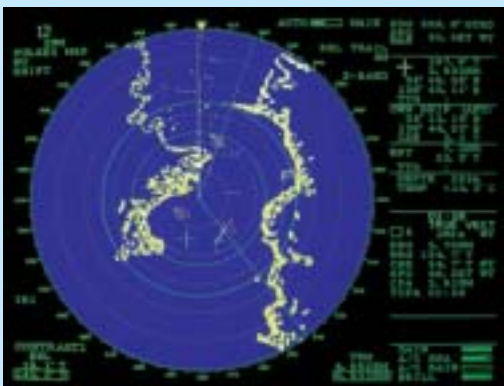

Electronic plotting of 10 targets according to the new IMO and IEC standards. Automatically redraw vectors between manual plots, drops off vectors if not plotted more than 10 min as required by IMO/IEC.

Automatic Tracking Aid (ATA) ARP-17 (Optional)

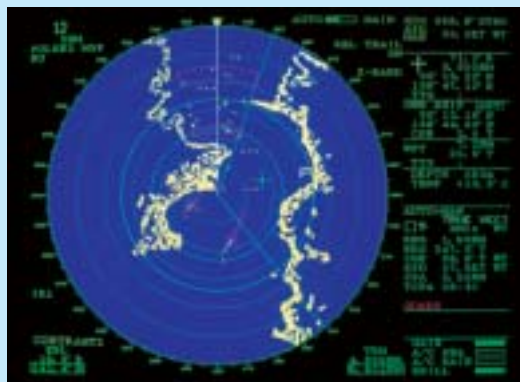

The Auto Plotter ARP-17 automatically tracks up to 20 targets acquired manually or automatically, presents target data, and triggers a collision alarm for the target on a collision course.

Target acquisition: Automatic or manual acquisition of up to 20 targets in 0.2-32 nm
 Tracking range: 0.1-32 nm
 Vector length: 0.5, 1, 3, 6, 15, 30 min, true or relative
 Audio-visual alarm: Produced against lost targets and threatening targets
 Target data display: Range, bearing, course, speed and CPA/TCPA of a chosen target

Note: ARP-17 can be used for 24 rpm scanner only.

Video Plotter RP-17 (Option)



The Video Plotter RP-17 provides radar maps and storage of navigation events on two IC cards - a memory card (RAM) for storing the operator-created radar maps and a chart card (ROM) storing FURUNO made digital charts. The memory card retains operator-created radar maps of a maximum of 3,000 points. A radar map is a combination of map lines and symbols whereby the user can define and input the navigation data, route planning and monitoring data. The chart card (ROM) can drive the Electronic Reference Chart (ERC) - digital chart published by the Japanese Hydrographic Bureau. Nav lines, coastlines, buoys, etc. produced by operator by 3000 points in Radar mode, 6000 points with 98 waypoints and 10 routes on IC card in Chart mode at intervals of 0-30 s.

Map area: 0.125 to 96 nm
 Latitude limits: 85°N to 85°S
 Plot interval: 0 to 30 s or 0 to 9,99 nm
 Memory: Chart mode: 6000 points for track points and marks, 98 waypoints, 10 routes.
 Radar map mode: 3000 points

SPECIFICATIONS OF FR-1505/1510/1525 MARK-3

ANTENNA RADIATOR

- Type** Slotted waveguide array
- Beamwidth**

Radiator type	XN12AF	XN20AF	XN24AF
Length	4 ft	6.5 ft	8 ft
Beamwidth (H)	1.8°	1.23°	0.95°
Beamwidth (V)	25°	20°	20°
- Rotation Speed** 24 or 42 rpm
- Wind load** 100 knots relative wind

RF TRANSCEIVER

- Frequency** 9410 ± 30 MHz (X-band)
- Output Power**

FR-1505 MARK-3:	6 kW
FR-1510 MARK-3:	12 kW
FR-1525 MARK-3:	25 kW
- Pulselengths and Pulse Repetition Rates (PRR)**

Range scales (nm)	P/L (µs)	PRR (Hz)
0.125, 0.25	0.07	3000
0.5	0.07/0.15	3000
0.75, 1.5	2 from 0.07/0.15/0.3	3000/1500
3	2 from 0.15/0.3/0.5/0.7	3000/1500
6	2 from 0.3/0.5/0.7/1.2	1500/1000
12, 24	2 from 0.5/0.7/1.2	1000/600
48, 96	1.2	600
- Mixer and Local Oscillator** Microwave integrated circuit (MIC)
- Duplexer** Ferrite circulator with diode limiter
- IF** 60 MHz, Logarithmic, BW 28/3 MHz
- Noise Figure** 6 dB

DISPLAY UNIT

- Picture Tube** 15-inch diagonal color CRT
Pixels: 1024 x 768 dots
Effective diameter: 185 mm
Echo color: Yellow or green echoes in 16 levels
- Presentation** Head-up, Course-up*, North-up*, Head-up true bearing*, True motion**
*Heading data required.
**Heading and speed data required.
- Range Scales and Range Ring Intervals (nm)**
Range: 0.125, 0.25, 0.5, 0.75, 1.5, 3, 6, 12, 24, 48, 96
Rings: 0.025, 0.05, 0.1, 0.25, 0.25, 0.5, 1, 2, 4, 8, 16
- Minimum Range and discrimination** 35 m
- Accuracy**
Range: 1% of range in use or 10 m, whichever is greater
Bearing: Better than 1°
- Echo Trails** True or relative echo trails in monotone or multilevel shading (Speed and heading data required for true echo trails)
Trail length: 15, 30 s, 1, 3, 6, 15, 30 min, or continuous
- EPA (Electronic Plotting Aid)** Manual plotting of up to 10 targets with auto follow-up, true/rel vectors with a specified vector length (30 s, 1, 3, 6, 15 or 30 min) and target data readout (Speed and heading data required for true vectors.)
- Interface**
Channel 1 Input: BWC, BWR, DBK, DBS, DBT, DPT, GGA, GLL, HDG, HDM, MDA, MTW (*), RMA, RMB, RMC, VBW, VTG, ZDA
Output: RSD (every 4 s), TTL (When A/C RAIN control is pressed.)
Channel 2 Input: DBK, DBS, DPT, MDA, MTW, VBW
Output: TTM
Channel 3 Input: HDB, HDM, HDT, VHW
Output: None
- Other Features** Automatic tuning, A/C sea/rain, Interference rejection, Second trace echo suppression, Echo stretch, Heading line off (self-returning), Two VRMs, Two EBLs with true/rel bearing readout*, EBL/VRM offset, Instant day/night brilliance setting, Trackball cursor with range and true/rel bearing* plus L/L** readouts, Parallel index lines, Off-centering (up to 75% of range scale), Quick restart in case of accidental power-off, Nav data display**, User-definable function key
*Heading data required for true bearing readout.
**Nav data inputs required.

ENVIRONMENTAL CONDITIONS (Meets IEC 60945)

- Temperature: -25°C to +70°C (Antenna unit)
-15°C to +55°C (Display unit)

POWER SUPPLY

12/24/32 VDC, 295 W max, or 115/230 VAC, 50/60 Hz, 1ø, 465 VA max.
440 VAC, 50/60 Hz with stepdown transformer RU-1803
(12 VDC for FR-1505/1510 MARK-3 only)

EQUIPMENT LIST

Standard

- Display Unit RDP-119 with sun visor (DC or AC) 1 unit
- Antenna Unit 1 unit
- Scanner: RSB-0074 (24 rpm) or RSB-0075 (42 rpm)
- Transceiver: RTR-067 (6 kW), RTR-062 (12 kW) or RTR-063 (25 kW)
- Antenna Cable 15, 20, 30 m (specify) 1 pc.
- Standard spare parts and installation materials 1 set
(Specify model number, power supply, antenna type and rpm, and length of antenna cable when ordering.)

Option

- Power Cable CVV-S8x2C 15 m (for DC set)
- Stepdown transformer RU-1803 (for 440 VAC, 50/60 Hz, 1ø mains)
- External Alarm Buzzer OP03-21
- Gyro Interface GC-8 (built-in type)
- Gyro Converter AD-100
- Video Plotter RP-17 (built-in type)
- Auto Plotter ARP-17 (ATA) For 24 rpm scanner only.
- Performance Monitor PM-30
- Handgrips
- Interface Kit for connection of XGA monitor OP03-153

ANTENNA UNIT

- RSB-0074/RTR-067/XN12AF:
31 kg 68 lb
RSB-0074/RTR-062/XN20AF:
37 kg 82 lb
RSB-0074/RTR-063/XN24AF:
40 kg 88 lb

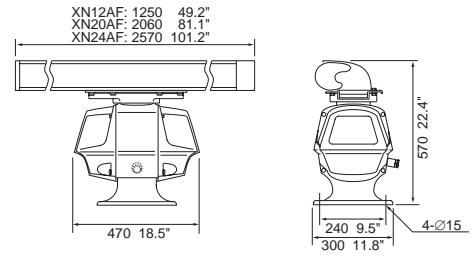

DISPLAY UNIT

29 kg, 64 lb

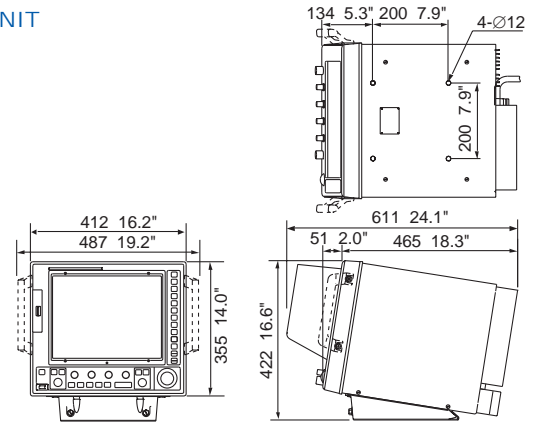

INTERCONNECTION DIAGRAM

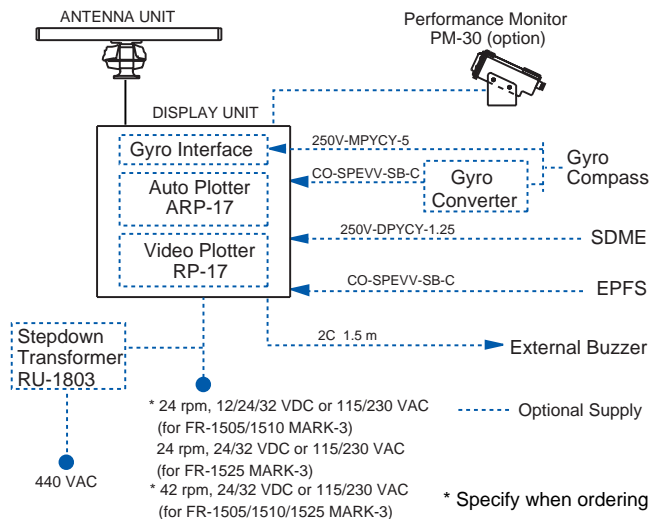

SPECIFICATIONS SUBJECT TO CHANGE WITHOUT NOTICE

FURUNO U.S.A., INC.
Camas, Washington, U.S.A.
Phone: +1 360-834-9300 Telefax: +1 360-834-9400

FURUNO (UK) LIMITED
Denmead, Hampshire, U.K.
Phone: +44 2392-230303 Telefax: +44 2392-230101

FURUNO FRANCE S.A.
Bordeaux-Mérignac, France
Phone: +33 05 56 13 48 00 Telefax: +33 05 56 13 48 01

FURUNO ESPAÑA S.A.
Madrid, Spain
Phone: +34 91-725-90-88 Telefax: +34 91-725-98-97

FURUNO DANMARK AS
Hvidovre, Denmark
Phone: +45 36 77 45 00 Telefax: +45 36 77 45 01

FURUNO NORGE AS
Ålesund, Norway
Phone: +47 70 102950 Telefax: +47 70 127021

FURUNO SVERIGE AB
Västra Frölunda, Sweden
Phone: +46 31-7098940 Telefax: +46 31-497093

FURUNO FINLAND OY
Espoo, Finland
Phone: +358 9 4355 670 Telefax: +358 9 4355 6710

04035N Printed in Japan