

FURUNO®

Multi directional detection, Split-Beam
COLOR VIDEO SOUNDER
with FURUNO's stabilizing technology

Model FCV-30

20.1" color SXGA LCD
MU-201C (option)



Trackball control unit

Optimize your fishing Multi-direction detection

- ▶ Frequency: 38 kHz; Output power : 4 kW
- ▶ Multi-beam system presents images received from up to five beams simultaneously
- ▶ Electronic beam stabilizer eliminates the loss of important targets due to ship's motion in rough seas (within up to 20 degrees)
- ▶ 7-degree sharp beamwidth gives a detailed echo image that is produced by high frequency beams

The FCV-30 is a high-performance echo sounder designed for variety of fishing applications. This echo sounder employs two new innovate techniques. One is "Multi-Beam" that facilitates multi directional and long-range fish detection. The other is "Split-Beam" which is commonly used in fish resource surveys. FURUNO's leading-edge signal processing technology makes the FCV-30 unparalleled in this class of sounder.

The FCV-30 provides a wide variety of presentation modes in high resolution SXGA or commonly used XGA resolution: Multi-Beam, Split-Beam, Zoom, and A-scope. Multi-Beam mode allows transmission in up to five directions simultaneously to show the location and distribution of a fish school around the vessel. The direction and tilt of each beam can be determined by the setting. This also helps understand the bottom composition, undulation and slope, allowing the operator to make an accurate judgment of best speed and course to trawl.

In the Split-beam mode, the FCV-30 has the unique functions called "Fish size assessment" and "Fish distribution". The former indicates the length of the target fish in the fish school by histogram. The later displays where the target fish is in the detected area and plots the detected fish's position.

The FCV-30 is of BlackBox configuration, consisting of a control, processor, transceiver units and a transducer.

The control unit consists only of a trackball, thumbwheel and several soft keys. Designed for use in commercial fishing FURUNO LCD MU-201C (20.1", SXGA), MU-151C (15.1", XGA) or a PC monitor can be utilized as a display unit.

The transducer employs highly sensitive transducer elements to achieve efficient energy conversion, which ensures long range detection with minimal output. This 38 kHz transducer features a narrow beamwidth (7°), which enables the detection of the shapes of fish, fish schools and fish distribution in minute detail.

With a built-in motion sensor, the beam stabilizer can be facilitated to eliminate the loss of important targets due to the ship's motion in rough seas. All beams are maintained at required tilt by compensating for ship's pitch and roll. FURUNO GPS satellite compass SC-50/110 detect ship's heave as well as pitch and roll. The satellite compass improves the echo presentation by compensating for echo ruffling caused by ship's heave. This gives an unwavering presentation of the echo images even in rough seas, and enhances the accuracy of the measurement for the fish size assessment display.



The future today with FURUNO's electronics technology.
FURUNO ELECTRICCO., LTD.
9-52 Ashihara-cho, Nishinomiya City, Japan Phone: +81 (0)798 65-2111
Fax: +81 (0)798 65-4200, 66-4622 URL: www.furuno.co.jp

Catalogue No. E-399a

TRADE MARK REGISTERED
MARCA REGISTRADA

operation with and Split-beam technology

- ▶ Heaving compensation* provides unwavering echo images

* The GPS satellite compass SC-50 or SC-110 works as a heaving sensor

- ▶ Fish size assessment display indicates the length of selected fish in the targeted fish school
- ▶ BlackBox system works with conventional SXGA/XGA PC monitors
- ▶ Straightforward operation by use of a trackball control unit

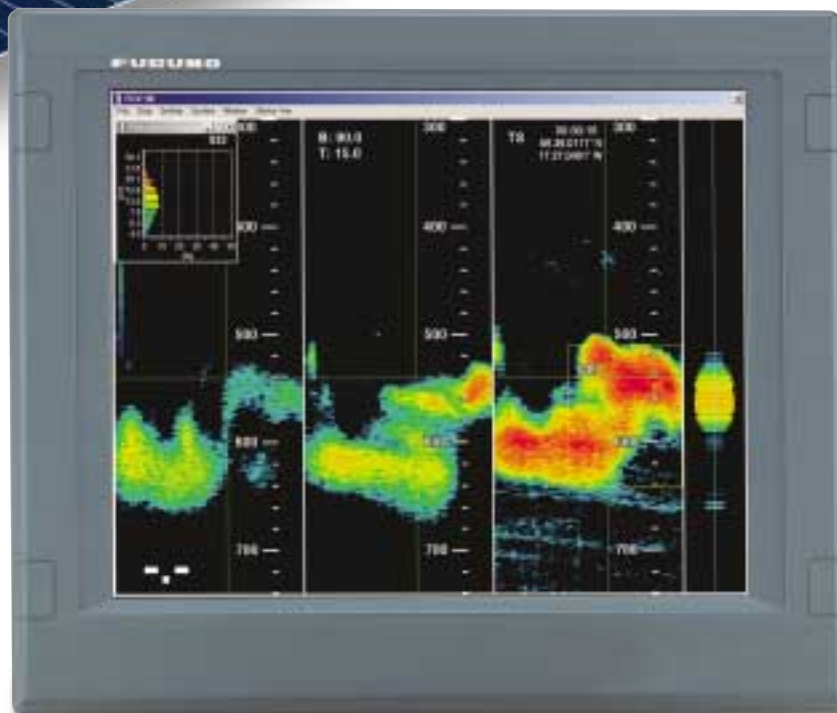

20.1" Color SXGA LCD MU-201C (option)



Transducer



Control Unit

SPECIFICATIONS OF FCV-30

DISPLAY

Display Unit
(Locally arranged) FURUNO 20.1" LCD MU-201C,
15" LCD MU-151C or commercial monitor
Resolution 1024x768 (XGA), 1280x1024 (SXGA)
Display Range
Range: 10-5000 m
Shift: 0-5000 m
Zoom Range: 2-200 m
Display Mode Split-beam, 3-beam, Split-beam + 2-beam, User1,
User2, User3

Display Window

Status, Temperature graph, Bottom discrimination graph, Fish size histogram, Target position graph, Bottom lock zoom, Bottom zoom, Marker zoom

Advance Speed Freeze, 1/8, 1/4, 1/2, 1/1, 2/1, 3/1, 4/1, 8/1
Alarm Bottom, Fish, Bottom fish, Temperature
A-scope Display Selectable among 1/6, 1/8 or 1/10 of screen width.
Each transmission displayed on A-scope
Raw data

Record

TRANSCIVER
Output Power 4 kW
TX Rate Max. 600 pulse/min
Frequency 38 kHz

Beam Control Range

Direction: 0-360°
Tilt: within 20°

Stabilization

Pitch/Roll: ±20° max.
Heave*: ±100 m max.
*Requires SC-50/110

INTERFACE

I/O Port NMEA, CIF, USB (2.0), LAN (10/100base-T)
Input

NMEA (IEC61162-1, NMEA0183 Ver. 1.5/2.0/3.0):
att, BWC, GGA, GLC, GLL, GNS, GTD, HVE,
MTW, RMA, RMB, RMC, VHW, VTG,ZDA
Water temperature, Net depth
CIF:
Output (IEC61162-1, NMEA0183 Ver. 1.5/2.0/3.0)
SDDBS, SDDBT, SDDPT, SDTLL, YCMTW,
SDvrm, SDbtm

POWER SUPPLY

Processor Unit 100-240 VAC, 3A-2A
Transceiver Unit 100-120/200-240 VAC, 5A-3A

ENVIRONMENT

Temperature

Processor Unit: 0°C to +40°C (32°F to +104°F)
Transducer: -5°C to +35°C (23°F to +95°F)
Transceiver Unit
• with Motion Sensor: -55°C to +45°C (5°F to +113°F)
• without Motion Sensor: -15°C to +55°C (5°F to +131°F)
Control Unit: -15°C to +55°C (5°F to +131°F)

Waterproofing

Control Unit: IP22 (front panel)

EQUIPMENT LIST

Standard

- Control Unit CV-301 1 unit
- Processor Unit CV-300 1 unit
- Transceiver Unit CV-302 (Specify when ordering) 1 unit
 - Built-in Motion Sensor JIMS-55S
 - Without Motion Sensor
- Transducer CV-303 with 15 m cable 1 unit
- Thru-hull Pipe TFB-1600 1 pc.
- Installation Materials and Standard Spare Parts 1 set

Option

- Junction Box CV-304
- Transducer Tank T-625

Control Unit CV-301

1.8 kg 4.0 lb

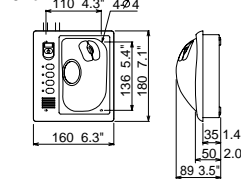

Transducer CV-303

42 kg 92.6 lb

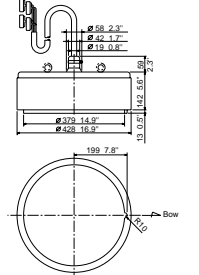

Transceiver Unit CV-302

34 kg 75.0 lb

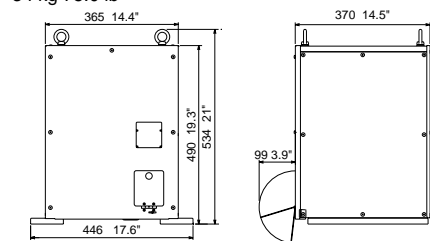

Processor Unit CV-300

7.5 kg 16.5 lb

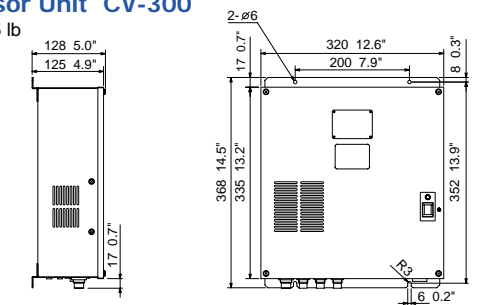

Display Unit (option) MU-201C

17.0 kg 37.5 lb

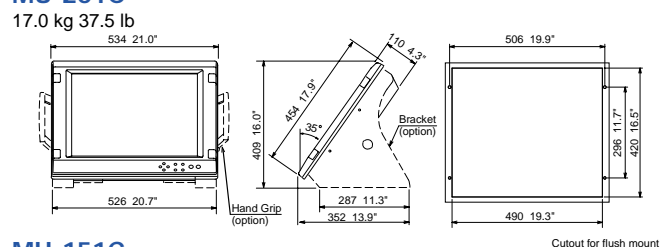

MU-151C

8.6 kg 19.0 lb

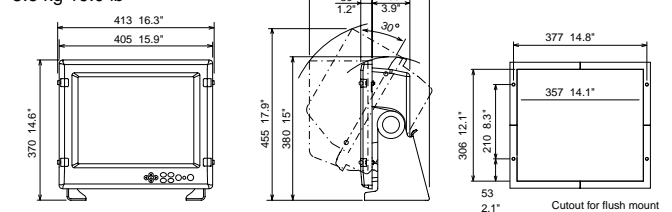

INTERCONNECTION DIAGRAM

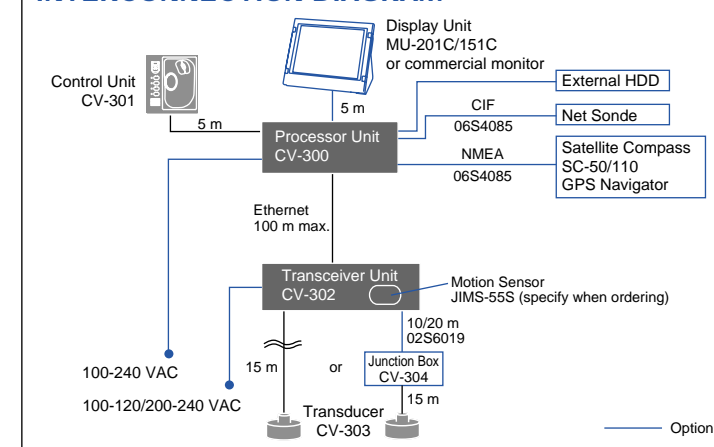

SPECIFICATIONS SUBJECT TO CHANGE WITHOUT NOTICE

FURUNO U.S.A., INC.
Camas, Washington, U.S.A.
Phone: +1 360-834-9300
Fax: +1 360-834-9400

FURUNO (UK) LIMITED
Denmead, Hampshire, U.K.
Phone: +44 2392-230303
Fax: +44 2392-230101

FURUNO FRANCE S.A.
Bordeaux-Mérignac, France
Phone: +33 5 56 13 48 00
Fax: +33 5 56 13 48 01

FURUNO ESPAÑA S.A.
Madrid, Spain
Phone: +34 91-725-90-88
Fax: +34 91-725-98-97

FURUNO DANMARK AS
Hvidovre, Denmark
Phone: +45 36 77 45 00
Fax: +45 36 77 45 01

FURUNO NORGE A/S
Ålesund, Norway
Phone: +47 70 102950
Fax: +47 70 127021

FURUNO SVERIGE AB
Västra Frölunda, Sweden
Phone: +46 31-7098940
Fax: +46 31-497093

FURUNO FINLAND OY
Espoo, Finland
Phone: +358 9 4355 670
Fax: +358 9 4355 6710

FURUNO POLSKA Sp. z o.o.
Gdynia, Poland
Phone: +48 58 669 02 20
Fax: +48 58 669 02 21

PRINTED WITH SOYINK. 05055U Printed in Japan

Multi-Beam

The FCV-30 detects fish schools in any five directions at the same time so that the location relative to the vessel and distribution of the targeted fish school can be recognized.

The operator can set five beams at any direction within 20 degrees by menu settings.

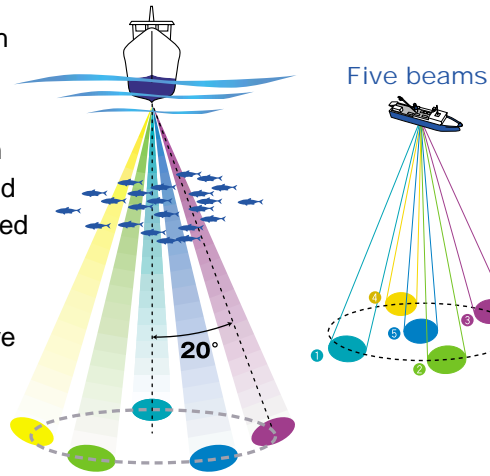

Five-beam presentation

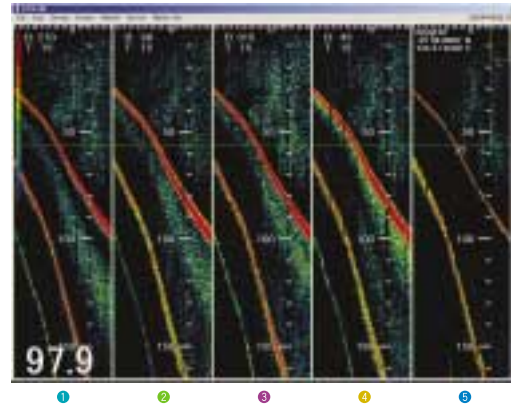

Three-beam presentation

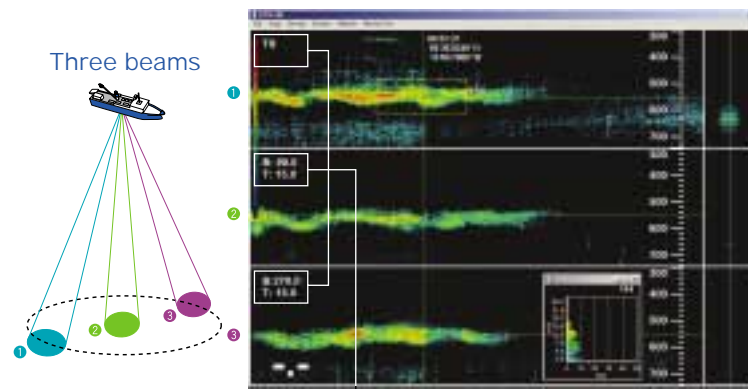

Beam setting window



Direction and tilt of each echo beam can easily be set in this window.

Flexible display setting

The FCV-30 features multi-beam presentation that displays echo images of up to five beams on one display. Arrangement of the display can be done from a menu window with just a few clicks of a button.

Multi split

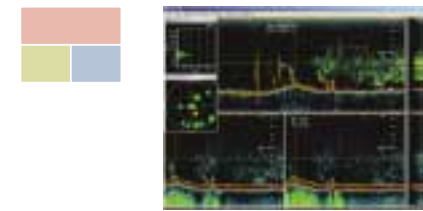

Horizontal split

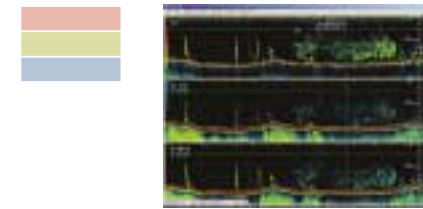

Vertical split

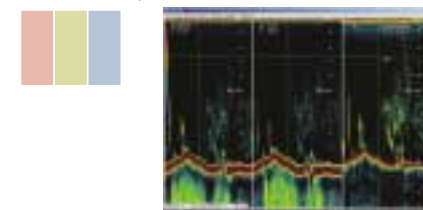

Why stabilizer is required!

Pitching and rolling produces adverse effect not only on the sounding image, but also on measurement of fish size. With FURUNO's exclusive Stabilizer Technology, the FCV-30 can stabilize both Tx and Rx beams independently so that unmatched accuracy is assured.

Stabilizer OFF

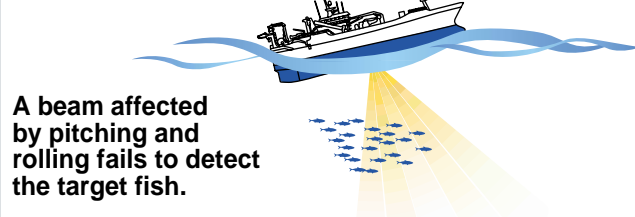

Stabilizer ON

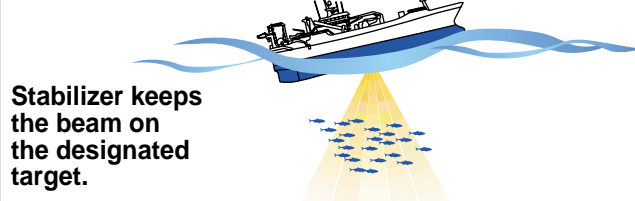

Furuno's exclusive Heaving Compensation with SC-50/110

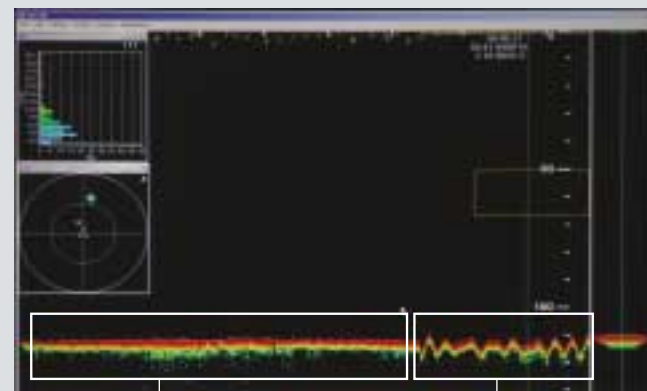

Heaving compensation ON

Even in rough sea conditions, the FCV-30 compensates for heaving, presenting a display without undulations.

Heaving compensation OFF

The bottom and fish echoes are wavering due to heaving of the vessel even though the bottom is flat.



The SC-50/110 are excellent heaving sensors to use with the FCV-30.

Multi-Beam

An Innovative Pr
with Split-bea

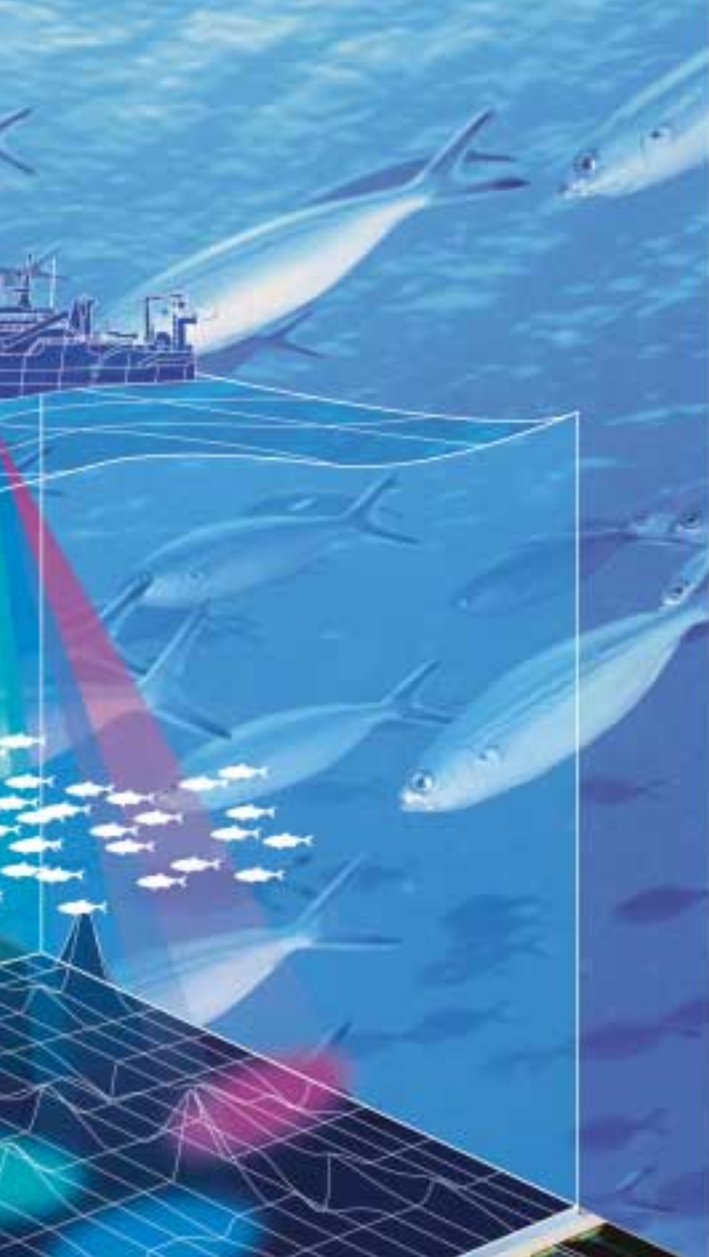

Split-Beam

Display window

There are nine display windows, which can be located anywhere on the screen. The background of these windows can be transparent or opaque allowing background images to be viewed.

- ▶ Status
- ▶ Temperature graph
- ▶ Bottom hardness chart (Bottom discrimination graph)
- ▶ Fish size assessment (Fish histogram)
- ▶ Fish distribution (Target position graph)
- ▶ Bottom lock
- ▶ Bottom zoom
- ▶ Marker zoom

Alert	Picture Advise	Time	Course	Heave
OFF	1/1	00:10	275.0°	-32.77m
5.0	0 m	15.3 °C	17.8 kt	1.6°
Temperature (below surface)		34	21.5912° N	32.7m/265.1°
40.6 m		136 08.4732° E	13234.5 / 32234.7	

Status display

The bottom characteristic

FCV-30 can plot bottom hardness with a line graph by analyzing the strength of returning echoes. This is useful for searching for a good fishing spot by finding bottom hardness. This chart indicates hardness on a scale of one to ten.



Split-Beam

Split-beam is an epoch-making technology for analyzing the size and distribution of a targeted fish school. Split-beam allows you to analyze a fish school before targeting it for to be catch.

- How long is the target fish in the targeted fish school
- How the fish school moves

By analyzing the size, volume and movement of a targeted fish school, operators can easily decide what to catch and what not to catch. It is indispensable for deciding when to go for a catch and eliminates fish schools which are smaller than desired. Also, it greatly contributes to fishery resource management or fish resources survey.

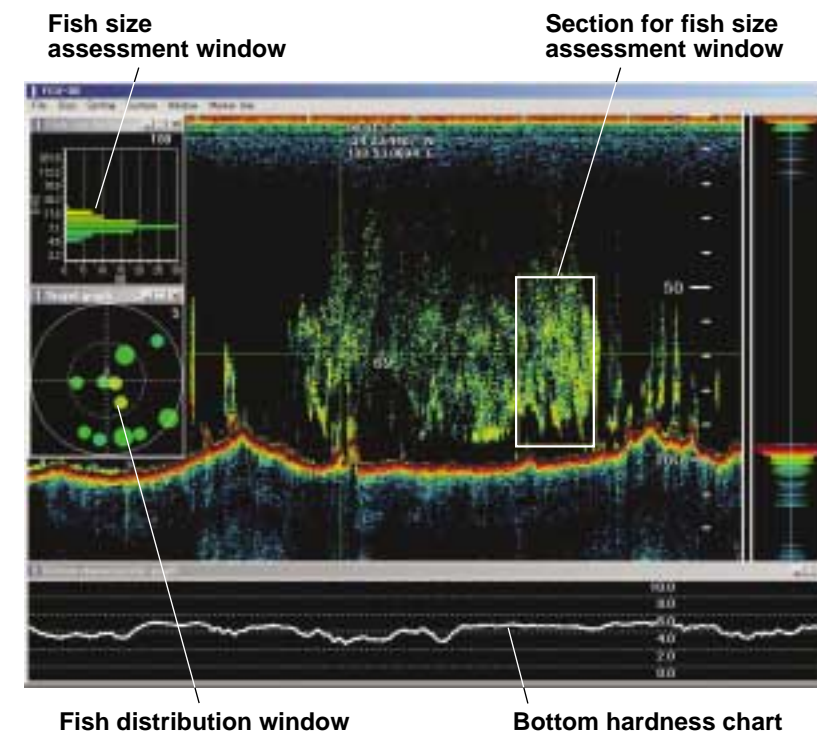

Fish size assessment

The fish size assessment feature shows fish size within a user-selected measuring area. The bar graph shows size and proportion of fish in the measuring area selected. The vertical axis shows fish length and the horizontal axis shows distribution.

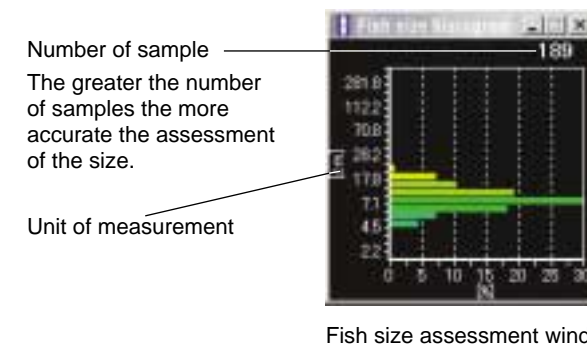

Fish distribution

The fish distribution display shows the targeted fish's position and movement. They are shown on the circle, whose scale is adjustable between ± 2 to 5 degrees under the vessel.

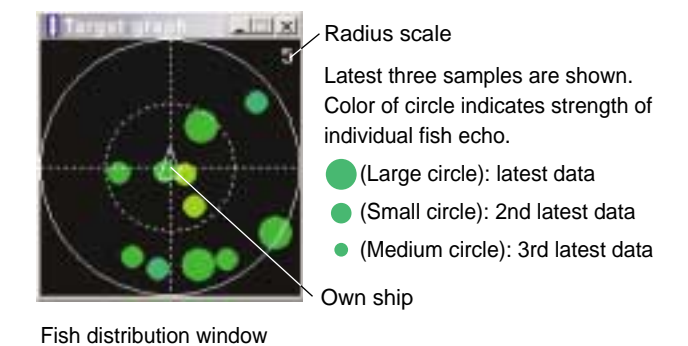

Sample Images

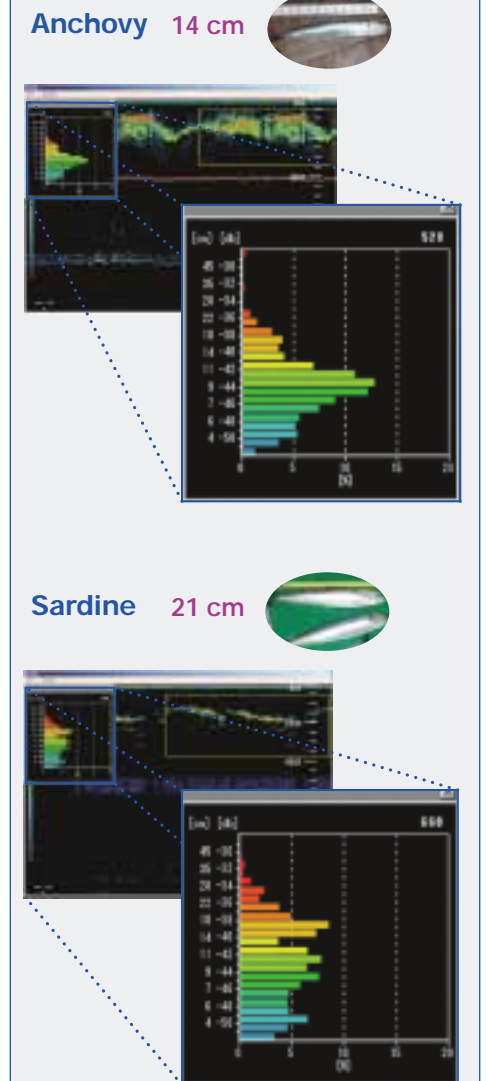

*recision Sounder
m Technology*