

- Comply with the latest IEC standards
- AVCS ENC Supported
- Built-in wide-range isolated power supply
- Completely isolated interface to avoid interaction
- 1280x1024 high-resolution color LCD, touch screen operation
- Brightness control on panel, convenient for night navigation
- Industrial design for marine use
- Android O/S for easy operation
- Type approved by CCS



- NES-1000 ECS is an electronic chart system, which is designed to comply with the latest IEC and IHO S52 standards.
- Electronic chart display, illimitable zoom.
- Position, COG, SOG and heading displayed.
- CPA/TCPA calculation, Navigation functions with route plan.
- AIS targets displayed on the chart
- The inputs include GNSS, AIS, VDR, Echo Sounder and HDG data.



SPECIFICATIONS

● MAIN UNIT

- Resolution: 1280×1024
- Display Color: 16.7M, 6bits+FRC
- Display Size: 19 inch
- Protected Glass: Bonding Glass
- Power Supply: DC 24V (range 9V~36V)
- Size: 451 (W) × 418.3 (H) × 97.7 (D) mm
- Weight: 14 kg
- Interface: RS232×2, RS422×4
RS422 (standby) ×4
USB×2, RJ45×1, DI/DO×2, HDMI×1

● MONITORING

- Own Ship: Position, COG, SOG, Heading
- AIS Targets: AIS Class A, AIS Class B,
AIS AtoN Station, AIS MOB
AIS Base Station
CPA/TCPA
- AIS Alert:
- S/W
- OS: Android
- Operation Method: Touch screen operation, Mouse, Keyboard
- Chart Update: USB
- IP GRADE: IP22

EQUIPMENT LIST

● STANDARD

- Main Unit (19 inch) NES-1000
- Mouse NES-1000T
- Keyboard NES-1000K
- Installation Material



SIZE DIMENSION

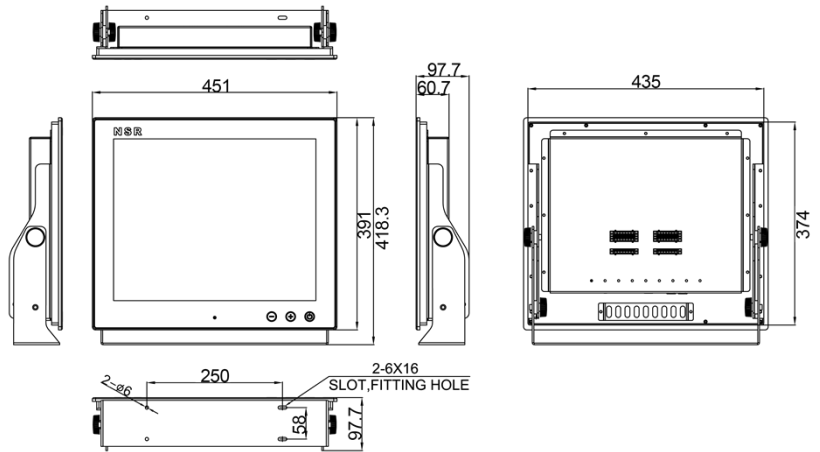

SYSTEM DIAGRAM

