



FURUNO®

Class-A Universal AIS Automatic Identification System

Model FA-100

The AIS improves the safety of navigation by assisting in the efficient navigation of ships, protection of the environment, and operation of Vessel Traffic Services by satisfying the following functional requirements:

- ship-to-ship mode for collision avoidance
- a means for littoral states to obtain information about a ship and its cargo
- VTS tool, i.e., ship-to-shore traffic management



The future today with FURUNO's electronics technology.

FURUNO ELECTRIC CO., LTD.

9-52 Ashihara-cho, Nishinomiya City, Japan Telephone: +81 (0)798 65-2111
Telefax: +81 (0)798 65-4200, 66-4622 URL: www.furuno.co.jp

Catalogue No. N-848a

TRADE MARK REGISTERED
MARCA REGISTRADA

FURUNO AIS on standalone trans

- Class-A Universal AIS complying with IMO MSC.74(69) Annex 3, IEC 61993-2, ITU-R M.1371-1
- Target ship's CPA/TCPA, COG/SOG, name on the basic scrolled LCD display
- Extensive AIS target data on radar; target symbols complying with IMO SN/Circ.217
- Interfaces for radar, ECDIS, PC. Future expansion - LAN and Long Range AIS operation
- Built-in GPS receiver for UTC synchronization and backup position fixing
- Heading information by GPS compass SC-60/120 or gyrocompass
- Existing radars FR-15x5 MK3, FR-21x5 and FAR-28x5 series can be upgraded for AIS target view by retrofitting the RP card



The FA-100 is a universal shipborne AIS capable of exchanging navigation and ship data between own ship and other ships or coastal stations. It complies with IMO MSC.74(69) Annex 3, A.694, ITU-R M.1371-1 and DSC ITU-R M.825. It also complies with IEC 61993-2 (Type testing standard), IEC 60945 (EMC and environmental conditions).

The FA-100 consists of VHF/GPS antennas, a transponder unit and several associated units. The transponder contains a VHF transmitter, two TDMA receivers on two parallel VHF channels, a DSC channel 70 receiver, interface, communication processor, LCD display, and internal GPS receiver. The internal 12-channel all-in-view GPS receiver with a differential capability provides UTC reference for

system synchronization to eliminate clash among a multiple users. It also gives position, COG and SOG when the external GPS fails.

The LCD panel displays all required information about Static data, Dynamic data, Voyage related data and Short safety-related messages. The information and messages are automatically updated according to the ITU-R M.1371-1, e.g., static information every 6 min and on request, dynamic information every 10 s on ship faster than 3 kt and 3.3 s when changing course at 0-14 kt, etc.

Graphic mode



Responder display, on radar, on ECDIS

AIS Target information on radar image (by simulation)

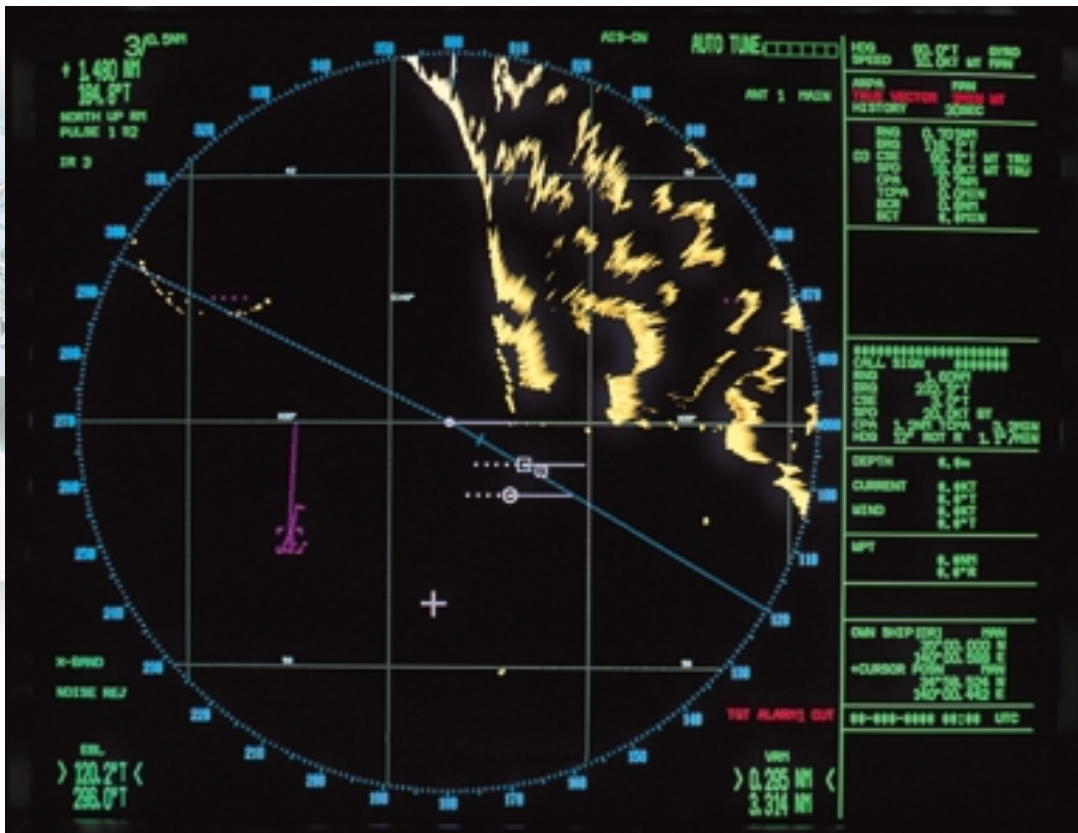

The AIS enhances detection of other ships and AtoN (aids to navigation) on radar screen.

- AIS targets are visible even if they are behind large ships, islands or points.
- AIS is not obscured by the sea clutter and rain clutter.
- Possible to predict course change of large ships by displaying ROT at tip of COG/SOG vector.

The AIS target symbols appear as defined by the SN/Circ.217 as follow: AIS COG/SOG vector changes its length with speed and adjustable in cycle time.

ROT mark is viewable at the COG/SOG vector tip when a target ship is equipped with a Furuno GPS compass SC-60 or 120.

The AIS target symbols can be overlaid on the radar FAR-28x5 series (with RP-340), FR-21x5 series (with RP-250) and FR-15x5 series (with RP-180). The new RP radar plotting modules provide practically unlimited number of AIS targets together with ARPA symbols.

Operational concept is common to all RP-modules. Place the cursor on an AIS target of interest and hit the AIS Data key, and the relevant data is visible on the data area below the ARPA data cell. If multiple AIS symbols mask the ARPA and radar picture, you can sleep the AIS targets. The triangle symbols get smaller for positive observation of ARPA symbols.

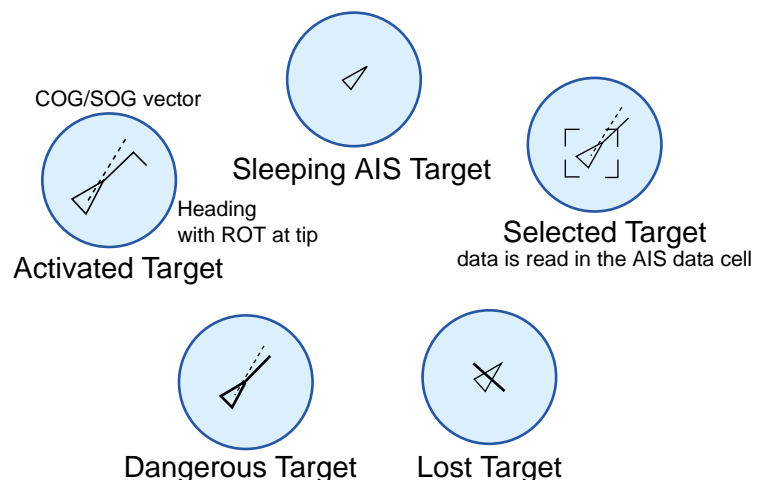

AIS System Overview

The Automatic Identification System (AIS) was originally developed to aid the Vessel Traffic Services (VTS) by use of VHF transponder working on Digital Selective Call (DSC) at VHF Channel 70 and is still in use along the UK coastal areas and others. Afterward the IMO developed a Universal AIS using the new sophisticated technology called Self-Organized Time Division Multiple Access (SOTDMA) based on a VHF Data Link (VDL).

This system is synchronized with GPS time to avoid conflict among multiple users (IMO minimum 2000 reports per minute and IEC requires 4500 reports on two channels).

The system operates in 3 modes - autonomous (continuous operation in all areas), assigned (data transmission interval remotely controlled by authority in traffic monitoring service) and polled (in response to interrogation from a ship or authority). The VHF channels 87B and 88B are commonly used and in addition there are local AIS frequencies. The shipborne AIS transponders exchange various data as specified by the IMO and ITU on either frequency automatically set up by the frequency management telecommand received by the DSC receiver on ship. VHF transmit power is also set up for 12.5 W or 2 W automatically.

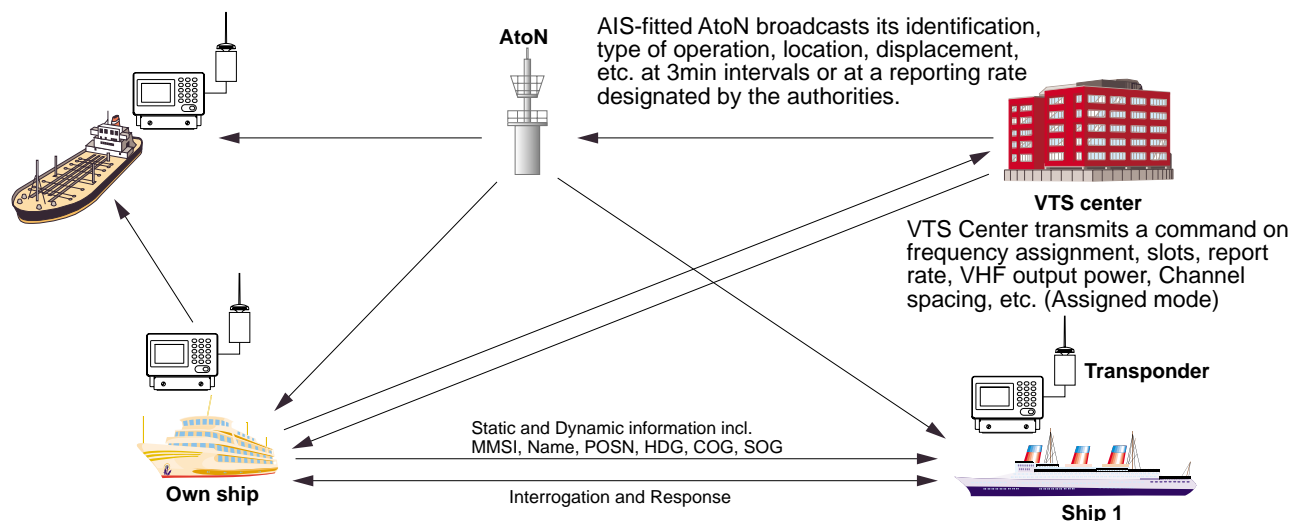

All ships broadcast Static and Dynamic information (autonomous and continuous mode).
If OS wants to know information about ship 1, OS shall send an interrogation in polling mode; then ship 1 will transmit her response on the same VHF channel without operator intervention.

■ Static Data

- MMSI (Maritime Mobile Service Identity)
- IMO number (Where available)
- Call sign & name
- Length and beam
- Type of ship
- Location of position-fixing antenna on the ship

■ Dynamic data

- Ship's position with accuracy indication and integrity status
- UTC
- Course over ground (COG)
- Speed over ground (SOG)
- Heading
- Navigation status (manual input)
- Rate of turn (where available)
- Update rates Dependent on speed and course alternation (2 s – 3 min)

■ Voyage related data

- Ship's draught
- Hazardous cargo (type)
- Destination and ETA (at masters discretion)

■ Short safety-related messages

- Free messages

Implementation schedule

(MSC.73 adopted 5 December 2001)

- All ships of ≥ 300 GT on int'l voyages and cargo ships ≥ 500 GT not on int'l voyages and passenger ships irrespective of size: 1 July 2002
- Ships on int'l voyages constructed before 1 July 2002
 - Passenger ships: before 1 July 2003
 - Tankers: before first survey of safety equipment after 1 July 2003
 - Other ships $\geq 50,000$ GT: before 1 July 2004
 - Other ships $\geq 10,000$ GT: before 1 July 2005
 - Other ships $\geq 3,000$ GT: before 1 July 2006
 - Other ships ≥ 300 GT: before 1 July 2007
- Ships not on int'l voyages constructed before 1 July 2002: before 1 July 2008

Transponder Unit

FA-100 Weight: 6.5 kg, 14.3 lb

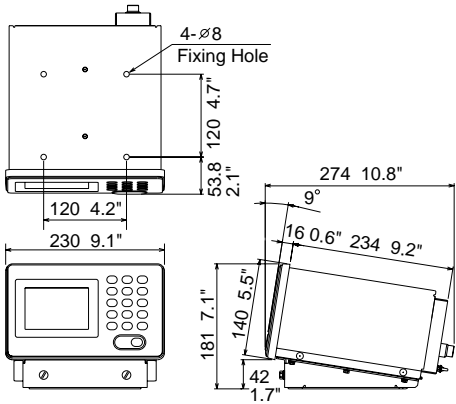

GPS Antenna

GSC-001

Weight: 1.0 kg, 2.2 lb

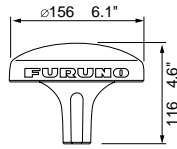

GPS/VHF Combined Antenna

GVA-100

Weight: 5 kg, 11.0 lb

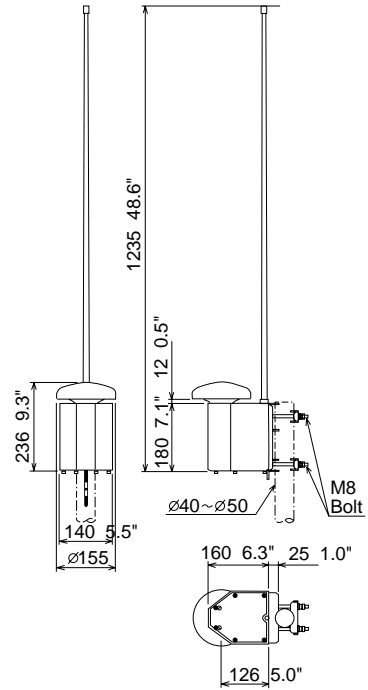

Junction Box

CB-100 Weight: 2 kg, 4.41 lb

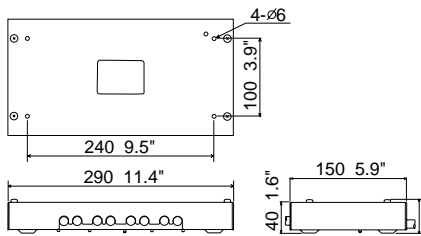

Distribution Box

DB-1 Weight: 0.7 kg, 1.54 lb

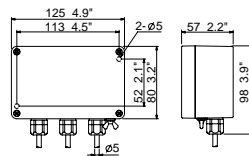

Interconnection diagram

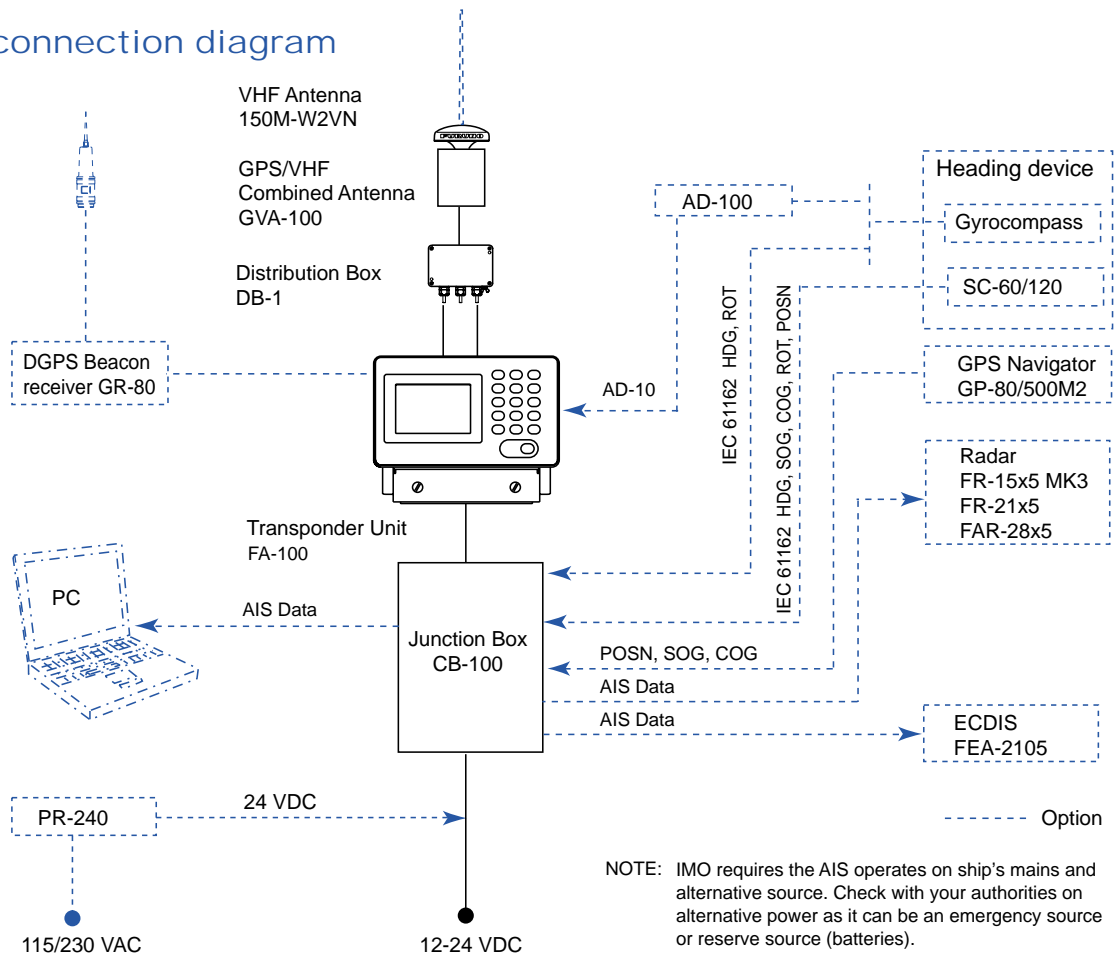

SPECIFICATIONS OF FA-100

GENERAL

Standards IMO MSC.74(69) Annex 3,
IEC 61993-2, ITU-R M.1371-1

Ship reporting capacity

2000 reports per minute, 4500 reports per minute on two channels

TDMA Transmitter

TX Frequency: 156.025 MHz - 162.025 MHz, manual/automatic setting
Transmitter Power: 2 W, 12.5 W manual/automatic selection

TDMA Receiver

RX Frequency: 156.025 MHz-162.025 MHz by 2 channels
RX1: Default CH87B (161.975 MHz), manual/automatic setting
RX2: Default CH88B (162.025 MHz), manual/automatic setting
Channel Spacing: 25 kHz and 12.5 kHz

DSC Receiver

RX Frequency: CH70 (156.525 MHz)

Internal GPS Receiver

Type: GN-79N5A-N, 12 CH
Accuracy: 10 m (GPS), 5 m (DGPS with optional beacon receiver)

UTC Synchronization Jitter (time between slot start and transmitter on): $\pm 100 \mu\text{s}$

External GPS Receiver

GP-80, GP-500 MK 2, SC-60/SC-120 (if approved by Administrations)

Navigational data

COG/SOG, ROT, POS, Heading from external sources

Display

Text (meets IMO minimum requirements) scrolled on LCD screen 95 x 65 mm

Graphical (optional) on Radar model FR-15x5 MK 3 Series (with RP-180 module), FR-21x5 Series (with RP-250 module), FAR-28x5 Series (with RP-340 module)

Existing radars can be upgraded for AIS target view with one of these RP cards.

INTERFACE

Input ABM, ACA, ACK, AIR, BBM, DTM, GBS, GGA, GLL, GNS, HDT, OSD, SSD, RMC, ROT, VBW, VSD, VTG

Output ABK, VDO, VDM, ACA, ACS, ALR, LRF, LR1, LR2, LR3, TXT

POWER SUPPLY

12-24 VDC, 7-3.5 A, 115/230 VAC with rectifier

ENVIRONMENT

IEC 60945 for EMC, Vibration, Temperature

EQUIPMENT LIST

Standard

- | | |
|---|--------|
| 1. Transponder Unit | 1 unit |
| 2. GPS Antenna Unit GSC-001 or GPS/VHF Combined Antenna Unit GVA-100 with Distribution Box DB-1 | 1 unit |
| 3. Junction Box CB-100 | 1 unit |
| 4. Installation Materials and Spare Parts | 1 set |

Optional

- VHF Antenna Unit 150M-W2VN
- GPS/VHF Combined and GPS Antenna Cable kit TNC-PS-3D-15 (15 m), CP20-01700 (30 m), CP20-01710 (50 m)
- VHF Antenna Cable Kit 5D-2V (10/20 m selectable)
- Antenna Base No. 13-QA330, No. 13-QA310, No. 13-RC5160
- Antenna Bracket for VHF Antenna 4-31071
- Software for PC
- DGPS Beacon Receiver GR-80
- Flush Mount Kit A and B
- Power Supply Unit PR-240

Note: IMO requires the AIS operates on ship's mains (115/230 VAC) and alternative source, then a PR-240 is required. Check with your authorities for alternative power as it can be an emergency source (AC generator) or reserve source (batteries).

SPECIFICATIONS SUBJECT TO CHANGE WITHOUT NOTICE

02065N Printed in Japan

FURUNO U.S.A., INC.

Camas, Washington, U.S.A.
Phone: +1 360-834-9300 Telefax: +1 360-834-9400

FURUNO (UK) LIMITED

Denmead, Hampshire, U.K.
Phone: +44 2392-230303 Telefax: +44 2392-230101

FURUNO FRANCE S.A.

Bordeaux-Mérignac, France
Phone: +33 5 56 13 48 00 Telefax: +33 5 56 13 48 01

FURUNO ESPANA S.A.

Madrid, Spain
Phone: +34 91-725-90-88 Telefax: +34 91-725-98-97

FURUNO DANMARK AS

Hvidovre, Denmark
Phone: +45 36 77 45 00 Telefax: +45 36 77 45 01

FURUNO NORGE A/S

Ålesund, Norway
Phone: +47 70 102950 Telefax: +47 70 127021

FURUNO SVERIGE AB

Västra Frölunda, Sweden
Phone: +46 31-7098940 Telefax: +46 31-497093

FURUNO SUOMI OY

Helsinki, Finland
Phone: +358 9 341 7570 Telefax: +358 9 341 5716