

IMCOS-5362 Standard automatic telephone



Product description

IMCOS-5362 is an automatic analog telephone suitable for integration with IMCOS PABX.

Specifically designed for installations in offshore facilities as well as marine environments.

Available in different versions depending on the various installation locations.

Type approved by marine class societies: ABS, BV, CCS, DNV, GL, LR, RINA.

Features

- ABS. Non corrodible material
- Anti rolling handset
- Incoming call (RING LED) signal
- Busy line (IN USE LED) signal
- Redial button for the automatic dialing of the last telephone number called
- Flash button for special functions
- Dedicated headset with microphone suitable for noisy areas use
- Ingress Protection IP55
- Different versions available:
 - console mounting (IMCOS-5362-C)
 - wall mount (IMCOS-5362-W)
 - portable with pre-wired plug and socket (IMCOS-5362-P)
- Wall mounting version can be equipped with headset and microphone (IMCOS-5362-W-HS)

EATON

Powering Business Worldwide

Specification

Material	ABS – black colour	
Mounting	Console/wall mounting/portable version	
Wiring	Screw terminals (/C-/W)	
	2 m. prewired cable and plug (/P) Cable type: 1 pair (2 twisted cores) screened cable	
Cable glands	1XPG16; 1XPG13,5 (only /W)	
Ingress protection	IP 55	
Weight	0,8 Kg. (/C), 0,9 Kg (/W), 1,4 Kg (/P)	
Max/min temperature	+70/-25 °C	
Test certifications	Enclosure emissions	EN 55016-2-3 EN 60945
	Immunity	EN 61000
	Dry heat cycle	EN 60068-2-2
	Damp heat cycle	EN 60068-2-30
	Cold Test	EN 60068-2-1
	Salt mist	EN 60068-2-52
	Ingress protection	EN 60529
	Sinusoidal vibration	EN 60068-2-6

IMCOS-5362-W Dimensions & fixing

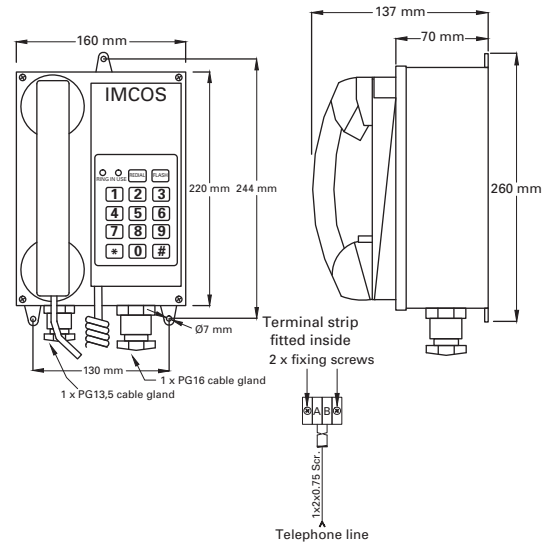

IMCOS-5362-C Dimensions & fixing

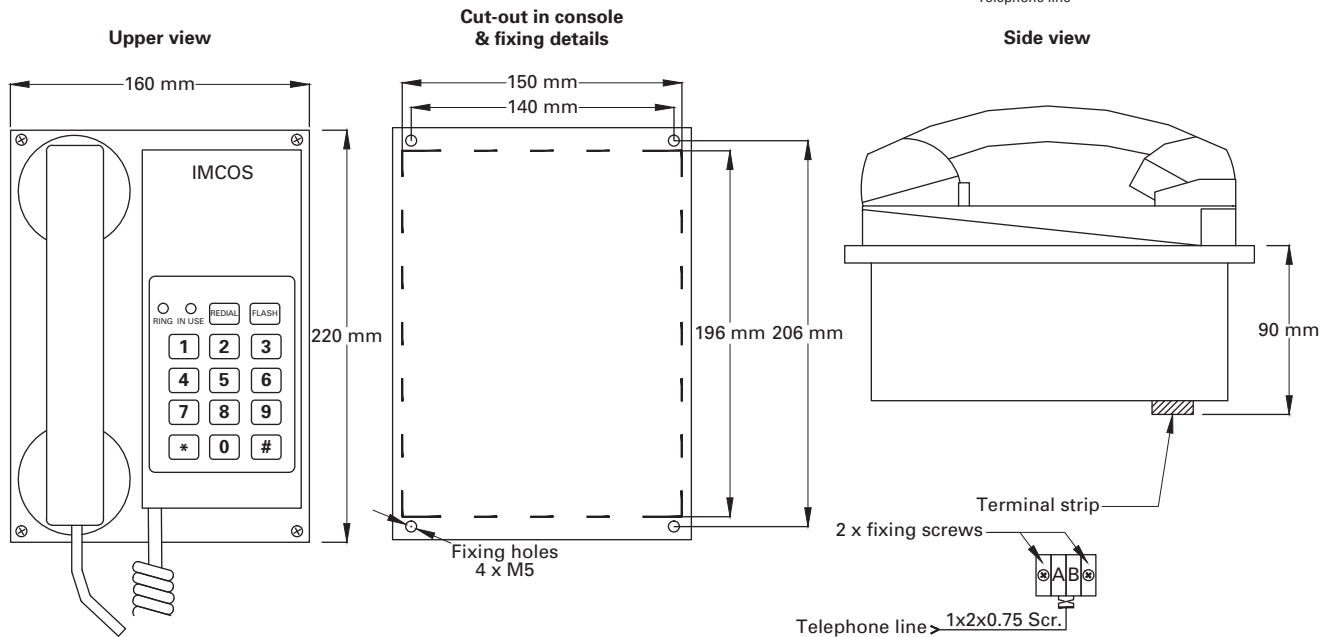

Ordering requirements

The following code is designed to help in selection of the correct unit. Build up the reference number by inserting the code for each component into the appropriate box.

Model	Mounting	Headset	Accessories																				
IMCOS-5362-x-y	x	y																					
	<table border="1"> <tr> <th>Entries</th> <th>Code</th> </tr> <tr> <td>Console</td> <td>C</td> </tr> <tr> <td>Wall</td> <td>W</td> </tr> <tr> <td>Portable</td> <td>P</td> </tr> </table>	Entries	Code	Console	C	Wall	W	Portable	P	<table border="1"> <tr> <th>Entries</th> <th>Code</th> </tr> <tr> <td>no headset</td> <td></td> </tr> <tr> <td>headset*</td> <td>HS</td> </tr> <tr> <td colspan="2">(*applicable to W model)</td> </tr> </table>	Entries	Code	no headset		headset*	HS	(*applicable to W model)		<table border="1"> <tr> <td>IMCOS-5362-S</td> <td>Socket for portable telephone</td> </tr> <tr> <td>IMCOS-9032</td> <td></td> </tr> </table>	IMCOS-5362-S	Socket for portable telephone	IMCOS-9032	
Entries	Code																						
Console	C																						
Wall	W																						
Portable	P																						
Entries	Code																						
no headset																							
headset*	HS																						
(*applicable to W model)																							
IMCOS-5362-S	Socket for portable telephone																						
IMCOS-9032																							

All specifications, dimensions, weights and tolerances are nominal (typical) and Gitiessse reserve the right to vary all data without prior notice. No liability is accepted for any consequence of use.

IMCOS™ System is type approved by seven marine class societies.