

IMCOS-5361 Automatic telephone with lighted keypad



Product description

IMCOS-5361 is a console mounting automatic telephone with illuminated keypad, suitable for ship's applications.

The illuminated keypad lights every time handset is lifted, allowing operation in low light conditions, as in navigation console or similar.

Type approved by marine class societies: ABS, BV, CCS, DNV, GL, LR, RINA.

Features

- ABS. Non corrodible material
- Illuminated keypad
- Anti rolling handset
- Incoming call (RING LED) signal
- Busy line (IN USE LED) signal
- Redial button for the automatic dialing of the last telephone number called
- Flash button for special functions
- Reset button to disengage the line
- Extensible handset lead up to 1,5 mt
- Ingress Protection IP55

EATON

Powering Business Worldwide

Specification

Material	ABS – black colour	
Mounting	Console	
Wiring	Screw terminals fitted on the bottom, outside internal cover Cable type: 1 pair (2 twisted cores) screened cable	
Cable glands	Not necessary	
Ingress protection	IP 55	
Weight	0.8 Kg	
Max/min temperature	+70/-25 °C	
Test certifications	Enclosure emissions	EN 55016-2-3 EN 60945
	Immunity	EN 61000
	Dry heat cycle	EN 60068-2-2
	Damp heat cycle	EN 60068-2-30
	Cold test	EN 60068-2-1
	Salt mist	EN 60068-2-52
	Ingress protection	EN 60529
	Sinusoidal vibration	EN 60068-2-6

IMCOS-5361 Dimensions & fixing

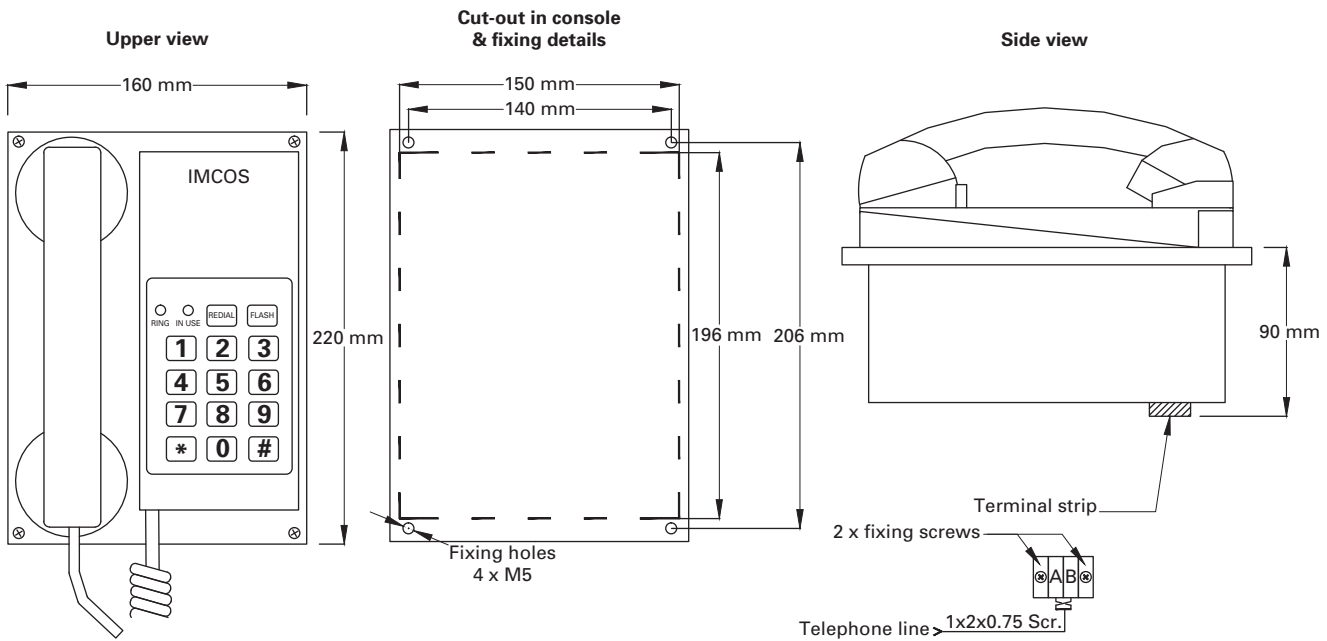

Ordering requirements

The following code is designed to help in selection of the correct unit. Build up the reference number by inserting the code for each component into the appropriate box.

Model

IMCOS-5361