

3006200044

## VSP-512

Intrinsically Safe Operating Unit



---

---

### Description

- ✓ Intrinsically safe operating unit
- ✓ Suitable for mounting in hazardous areas
- ✓ Ex II 1G (Zone 0)
- ✓ 12 extensions selector switch and a call button
- ✓ Used together with buffer unit mounted in safe area
- ✓ Delivered for wall mounting

### Technical Dimensions

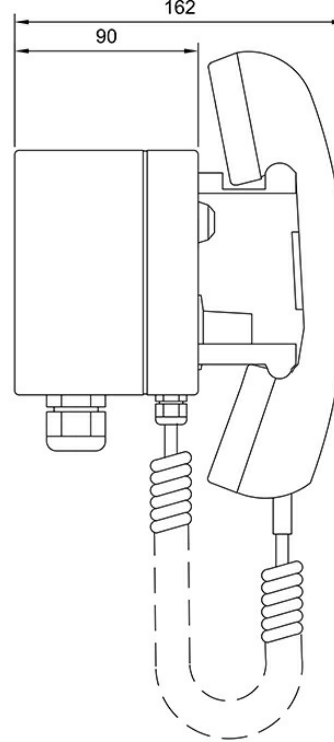
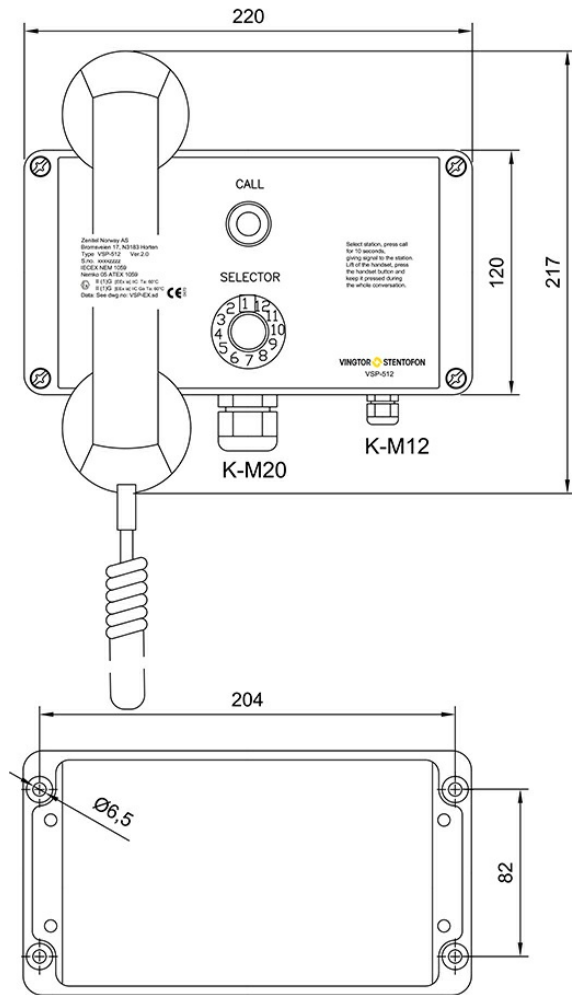

 ATEX Approved product
Certification body <b>Nemko</b>
Certificate no. <b>Nemko: 05 ATEX 1059</b>
Protection system <b>II (1)G [EEx ia] IIC Ta: 60°C</b>

# Specifications

## SPECIFICATIONS

Dimensions (WxHxD)	220 x 208 x 170 mm (with handset)
Mounting	Bulkhead
Weight	1,8 kg
Housing	Glassfibre reinforced polyester box
Color	Black
IP- rating	IP-44
Cable entry	M20 x 1,5
Connections	Screw terminals
Protection mode	Ex II 1 G EEx ia IIC T6
Certificate	Presafe 15 ATEX 6475 / IECEX PRE 15.0024

## Accessories



### VSP-512-AKHS-10

Headset with headband  
ATEX certified incl. 10 m  
cable



### VSP-512-AKHS-20

Headset with headband  
ATEX certified incl. 20m  
cable



### HANDSET COMPLETE FOR VSP-512

## Used With



VSP-5004

Ex Buffer Unit



VSP-5004/1

Ex Buffer Unit w 1x Zener Barrier



VSP-5004/2

Ex Buffer Unit w 2x Zener Barrier



VSP-5008

EX Buffer Unit



VSP-5012

EX Buffer Unit