



DNH

HEAD OFFICE, NORWAY

DNH AS

Phone..... + 47 35 98 56 00

Fax..... + 47 35 98 56 10

E-mail..... dnh@dnh.no

Web-Site..... www.dnh.no

ENGLAND

DNH WW Ltd

Phone..... + 44 1908 275 000

Fax..... + 44 1908 275 100

E-mail..... dnh@dnh.co.uk

GERMANY

DNH GmbH

Phone... + 49 040 6569 30-0

Fax..... + 49 040 6569 30-30

E-mail..... dnh@dnh.de

USA

DNH Speakers Inc

Phone..... + 1 484 494 5790

Fax..... + 1 484 494 5793

E-mail..dnh@dnhspeakers.com

ISO 9001 CERTIFIED

HP-6

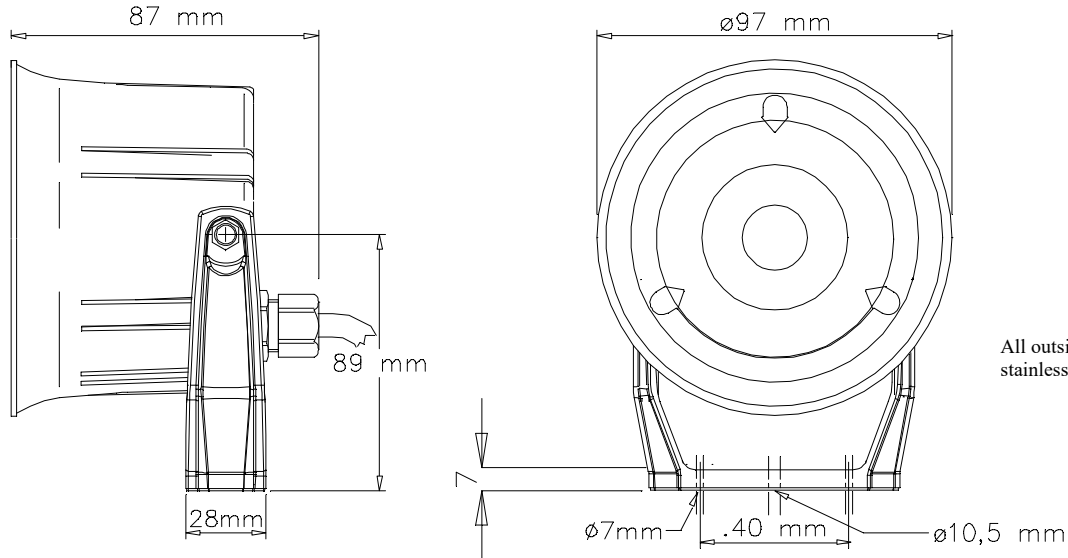

All outside nuts and screws in stainless steel.

Sound pressure levels at 1W/1m MP-6

SPL vs Freq



Specifications

Material / Color	Polyamide UL94 V0 / RAL 7035
Mounting	Bracket
Termination	Cable, 0,5m
Weight w/transformer	0,35
IP-rating	67
Max. / min. amb. temp	110°C / -40°C
Rated / max. power	6 W
SPL 1W/1m	100 dB
SPL rated power	107 dB
Effective freq. range	300 – 20000 Hz
Dispersion (-6dB) 1kHz / 4kHz	178° / 62°
Directivity factor, Q 1kHz/4kHz	2,0 / 5,8
Options	Impedance, colors, labels

Installation, Operation and Maintenance Procedures

- Fasten bracket with 1-3 screws, to wall or ceiling.
- To change the position of the loudspeaker, please adjust the bracket (by loosening / tightening the screws) as required.
- HP-6 is delivered with cable and the cable should be terminated in a suitable junction box.
- For optimum performance, always use the correct voltage / power and operate within the frequency limits as stated.
- This loudspeaker is supplied with two years warranty against defective materials and workmanship.

DNH reserves the right to alter specifications without notice

