

Released

X-band Radar Front End

Model No. NJT1028

Copyright©**Nisshinbo Micro Devices Inc.
Microwave Business Headquarters**

-Notice of Proprietary Information-

This document and its contents are proprietary to Nisshinbo Micro Devices Inc.
This publication and its contents may not be reproduced or distributed for any other purpose
without the written permission of Nisshinbo Micro Devices Inc.
Those specifications listed in this document are subject to change at any time.

■ GENERAL DESCRIPTION

NJT1028 is designed for the front end of marine radar system.

It features a small size and a light weight operable at any frequency between 9.38GHz and 9.44GHz.

This front end module consists of GaAs FET low noise amplifier, balanced mixer, Local VCO with buffer amplifier.

The stability of the local VCO frequency by the input RF power is increased effectively by the buffer amplifier which is located between balanced mixer and local VCO.



■ ELECTRICAL CHARACTERISTICS < at 25 °C >

PARAMETERS		MINIMUM	TYPICAL	MAXIMUM	UNITS
Operating voltage		4.8	5.0	5.2	V
Operating current		-	70	90	mA
Tuning Voltage	(Note1)	10.0	12.0	14.0	V
Local frequency	VT= 6V	-	-	9.41	GHz
	VT=24V	9.53	-	-	GHz
Noise figure	(Note2)	-	1.5	4.0	dB
Conversion gain	(Note2)	8.0	10.0	12.0	dB
RF single pulse burnout	(Note3)	-	-	600	mW
RF repetitive pulse burnout	(Note4)	-	-	400	mW

Note1: $f_{LO}=9.47\text{GHz}$

Note2: $f_{RF}=9.41\text{GHz}$, $P_d=10\text{nsec}$

Note3: DSB measurement.

Note4: $f_{RF}=9.41\text{GHz}$, $P_d=1\mu\text{sec}$, Duty=0.001

■ BLOCK DIAGRAM

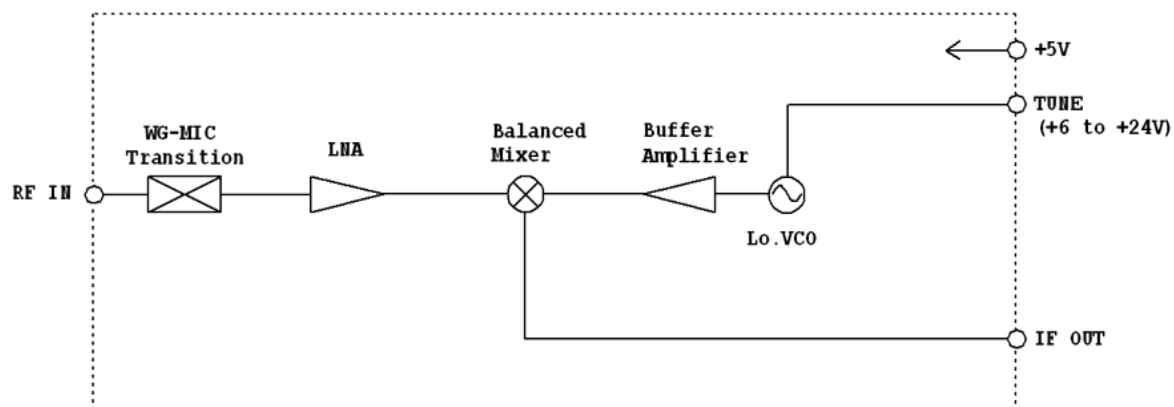

* Above Specifications are subject to change without notice.

■ OUTLINE

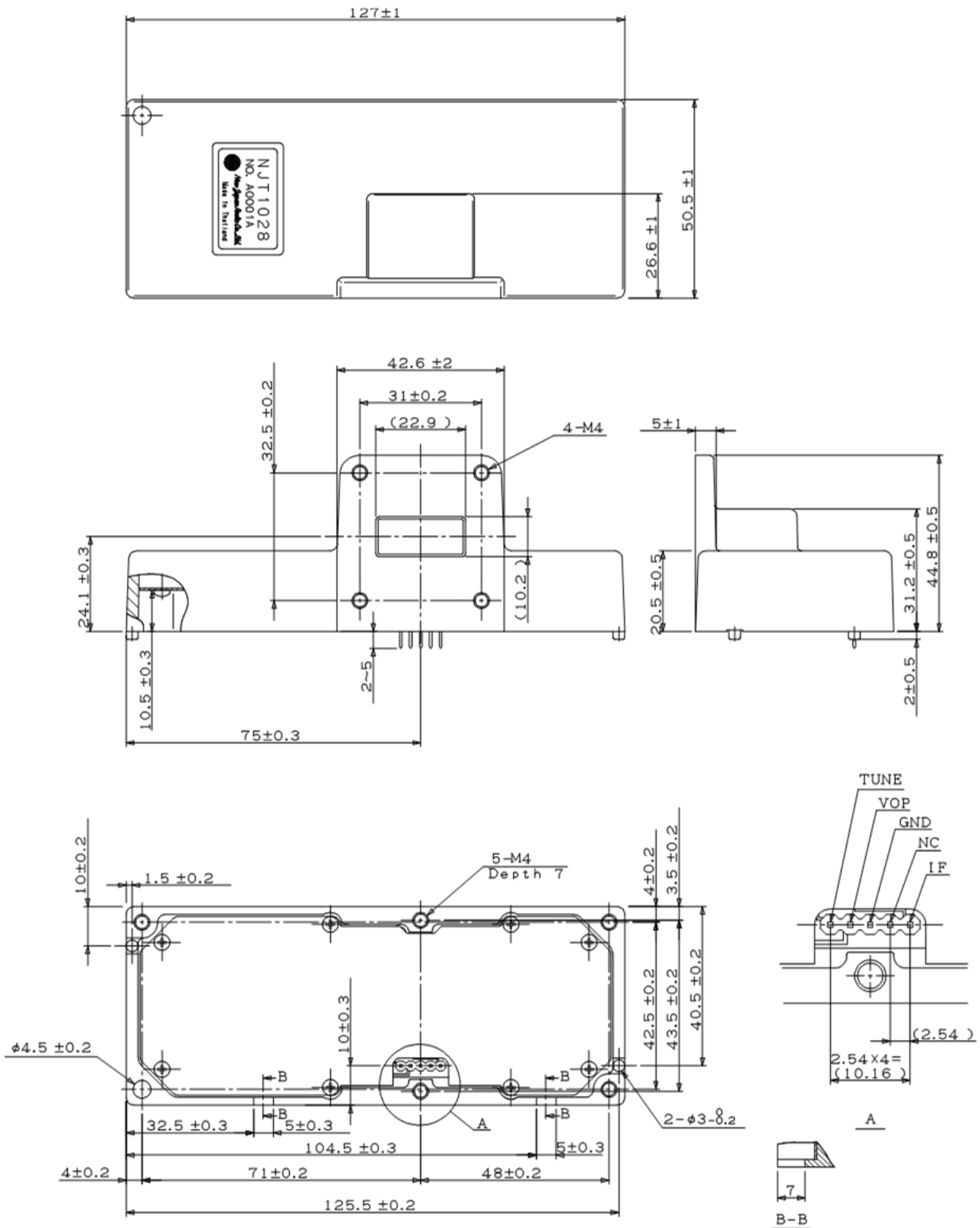

(Dimensions are expressed in "mm".)

* Above Specifications are subject to change without notice.

