

MSF1425B

X-Band Magnetron

MSF1425B is designed for the magnetron of x-band radar system. The frequency range is fixed <9380 - 9440MHz> and the peak output power is 10.5kW.

----- MAXIMUM RATINGS -----

	Min	Max	Unit
Peak anode current	3.0	7.0	A
Perk anode power input	-	50	kW
Duty cycle	-	0.001	-
Pulse duration	0.05	1.0	us
Rate of rise of voltage pulse	-	90	kV/us
Anode temperature	-	100	degree centigrade
V.S.W.R at the output coupler	-	1.5:1	-

----- ELECTRICAL -----

	Min	Typical	Max	Unit
Heater voltage (Note 1)	5.7	6.3	6.9	V
Preheat time	60	-	-	S
Peak anode voltage (Note 2)	5.4	5.6	6.0	kV
Peak output power (Note 2)	10	10.5	-	kW
Frequency (Note 2)	9380	9410	9440	MHz

Notes:

1. Measured with heater voltage of 6.3V and no anode input power, the heater current limits are 0.5A minimum, 0.6A maximum.

No reduction of heater voltage is required.

2. Measured at peak anode current 5.0A.

Rev.2

MSF 1425B

OUTLINE

Note: Dimensions are in mm

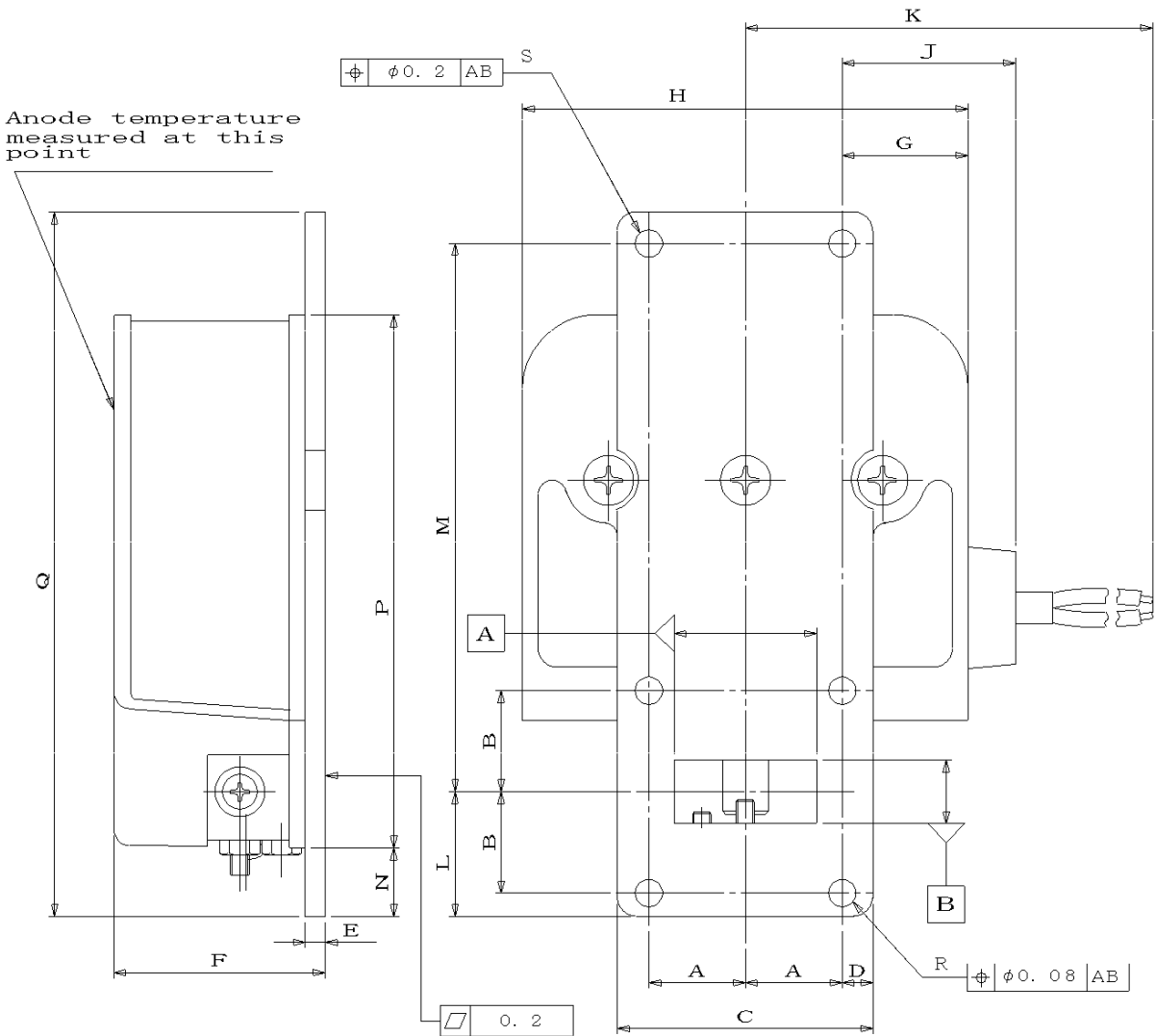

	MIN	MAX
A	15.5	
B	16.25	
C	40.8	41.2
D	4.8	5.2
E	2.7	3.7
F	-	36.0
G	-	21.5
H	-	74.0

	MIN	MAX
J	-	30.0
K	240	-
L	19.6	20.2
M	88	
N	10.0	-
P	-	86.0
Q	112.6	113.2
R	φ4.3	φ4.375
S	φ4.4	φ4.5

Lead Connections

Colour	Element
Green	Heater
Yellow	Heater, Cathode