

15.0×7.5×9.4



Features

- DIL pitch terminals .
- Conforms to FCC Part 68 2.5kV surge and dielectric 1500VAC.
- High contact capacity 2A/30VDC.
- Application for telecommunication equipment, office equipment, security alarm systems, measuring instruments, medical monitoring equipment , audio visual equipment, flight simulator, sensor control.

Ordering Information

NX 2 12 W
1 2 3 4

1 Part number: NX
2 Contact arrangement: 2:2C

3 Coil rated Voltage(V): DC:3,4.5,5,6,9,12,24
4 Contact Material: NIL:AgPd W:AgNi

Contact Data

Contact Arrangement	2C(DPDT(B-M)) (Bifurcated Crossbar)		
Contact Material	AgPd(Au plated) AgNi(Au plated)		
Contact Rating (Resistive)	2A/30VDC; 0.5A/125VAC		
Max. Switching Power	60W 62.5VA	Min. Switching Load: 0.01mA/10mV(Reference Value)	
Max. Switching Voltage	220VDC, 250VAC	Max. Switching Current:2A	
Contact Resistance	≤70mΩ	Item 4.12 of IEC 61810-7	
Operational Life	Electrical	1×10 ⁵	Item 4.30 of IEC 61810-7
	Mechanical	1×10 ⁸	Item 4.31 of IEC 61810-7

CAUTION:

Relays previously tested or used above 10mA resistive at 6V maximum (DC or peak AC) open circuit are not recommended for subsequent use in low level applications.

Coil Parameter

Dash numbers	Coil voltage VDC		Coil resistance Ω ±10%	Pick-up voltage VDC(max) (75%of rated voltage)	Drop-out voltage VDC(min) (10% of rated voltage)	Coil power W	Operate time ms	Release time ms
	Rated	Max.						
NX2-003	3	4.5	64.3	2.25	0.3	0.14	≤4	≤4
NX2-004	4.5	6.7	145	3.38	0.45	0.14		
NX2-005	5	7.5	178	3.75	0.5	0.14		
NX2-006	6	9.0	257	4.50	0.6	0.14		
NX2-009	9	13.5	579	6.75	0.9	0.14		
NX2-012	12	18.0	1028	9.00	1.2	0.14		
NX2-024	24	36.0	2880	18.0	2.4	0.20		

CAUTION: 1.The use of any coil voltage less than the rated coil voltage will compromise the operation of the relay.

2.Pickup and release voltage are for test purposes only and are not to be used as design criteria.

3.Unless otherwise stated, the rated coil voltage specified in coil parameter and its suitable polarity(if applicable) shall be used for all tests and its application to the relay.

Characteristics

Insulation Resistance	1000M Ω min (at 500VDC)	Item 4.11 of IEC 61810-7
Dielectric Strength		
Between Open Contacts Between Coil & Contacts Between Contact Poles	1000VAC 1min 1500VAC 1min 1000VAC 1min	Item 4.9 of IEC 61810-7
Surge Withstand Voltage		
Between Open Contacts Between Coil & Contacts	1500V 2500V	FCC 68
Shock Resistance	Functional:735m/s ² 11ms; Destructive:980 m/s ² 6ms	Item 4.26 of IEC 61810-7
Vibration Resistance	10Hz~55Hz Double amplitude Functional:3.3mm Destructive:5mm	Item 4.28 of IEC 61810-7
Terminals Strength	5N	Item 4.24 of IEC 61810-7
Temperature Range	-40 $^{\circ}$ C~85 $^{\circ}$ C(-40 $^{\circ}$ F~185 $^{\circ}$ F)	
Relative Humidity	5% to 85%	Item 4.16 of IEC 61810-7
Mass	Approx. 2g	Item 4.7 of IEC 61810-7

Safety Approvals

Safety approval	UL&CUR
Load	0.5A/125VAC; 2A/30VDC

Dimensions

mm

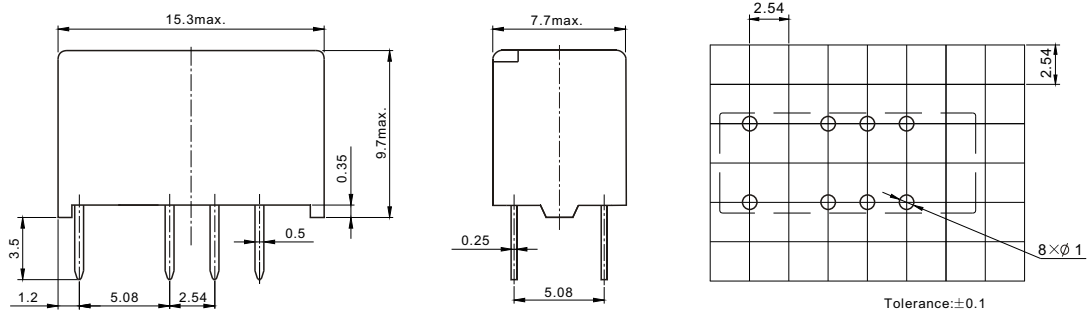

Dimensions

Mounting (Bottom view)

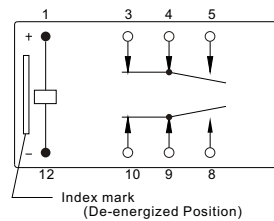

Wiring diagram(Bottom view)

CAUTION: In case of no tolerance shown in outline dimension: outline dimension ≤ 1 mm, tolerance should be ± 0.2 mm; outline dimension > 1 mm and ≤ 5 mm, tolerance should be ± 0.3 mm; outline dimension > 5 mm, tolerance should be ± 0.4 mm.