

NVFM



23.5×16×26

Features

- Switching capacity up to 35A.
- PC board mounting and insert mounting available.
- Suitable for automation system and automobile auxiliary etc.

Ordering Information

NVFM C Z 20 DC12V 1.5 b D

1 2 3 4 5 6 7 8

1 Part number: NVFM
 2 Contact arrangement: A:1A (1.2W); C:1C(1.5W)
 3 Enclosure: S: Wash tight ; Z: Flux proof
 4 Contact current: 25A:NO:35A/14VDC ; NC:25A/14VDC
 20A:NO:25A/14VDC ; NC:20A/14VDC

5 Coil rated voltage(V): DC:6,12,24,48
 6 Coil power: 1.2:1.2W; 1.5:1.5W
 7 Terminals: a: plug in type; b:PCB type
 8 Coil transient suppression: D: with diode
 R: with resistance
 NIL: standard

Contact Data

Contact Arrangement	1A(SPSTNO) 1C(SPDT(B-M))	
Contact Material	AgSnO ₂	
Contact Rating (Resistive)	NO:25A/14VDC, NC:20A/14VDC NO:35A/14VDC, NC:25A/14VDC NO:12A/28VDC, NC:10A/28VDC NO:15A/28VDC, NC:12A/28VDC	
Max. Switching Power	490W	
Max. Switching Voltage	30VDC	Max. Switching Current:35A
Voltage Drop(Initial)	Typ. 50mV(at 10A)	Item 4.12 of IEC 61810-7
Operation Life	Electrical	1×10 ⁵ Item 4.30 of IEC 61810-7
	Mechanical	1×10 ⁷ Item 4.31 of IEC 61810-7

Coil Parameter

Dash numbers	Coil voltage VDC		Coil resistance Ω ±10%	Pick-up voltage VDC(max) (70%of rated voltage)	Drop-out voltage VDC(min) (10% of rated voltage)	Coil power W	Operate time ms	Release time ms
	Rated	Max.						
006-1200	6	7.8	30	4.2	0.6	1.2	≤10	≤7
012-1200	12	15.6	120	8.4	1.2			
024-1200	24	31.2	480	16.8	2.4			
048-1200	48	62.4	1920	33.6	4.8			
006-1500	6	7.8	24	4.2	0.6	1.5	≤10	≤7
012-1500	12	15.6	96	8.4	1.2			
024-1500	24	31.2	384	16.8	2.4			
048-1500	48	62.4	1536	33.6	4.8			

CAUTION: 1.The use of any coil voltage less than the rated coil voltage will compromise the operation of the relay.
 2.Pickup and release voltage are for test purposes only and are not to be used as design criteria.

Characteristics

Insulation Resistance ¹⁾	100MΩ min (at 500VDC)	Item 4.11 of IEC 61810-7
Dielectric Strength ¹⁾ Between Contacts Between Contact and Coil	50Hz 500V 50Hz 1000V	Item 4.9 of IEC 61810-7 Item 4.9 of IEC 61810-7
Shock Resistance	98m/s ² 11ms	Item 4.26 of IEC 61810-7
Vibration Resistance	10Hz~40Hz Double amplitude 1.27mm	Item 4.28 of IEC 61810-7
Terminals Strength	100N	Item 4.24 of IEC 61810-7
Ambient Temperature	-40℃~125℃	
Relative Humidity	5% to 85%	Item 4.16 of IEC 61810-7
Mass	18.5g	Item 4.7 of IEC 61810-7

Note: 1). When testing, coil terminals should be connected, if coil transient suppression is installed in relay .

Dimensions

mm

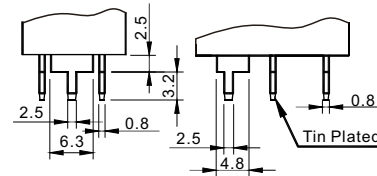
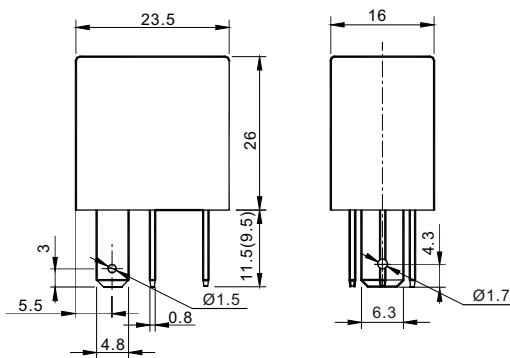

Note: Terminals as shown above are also available.

Dimensions

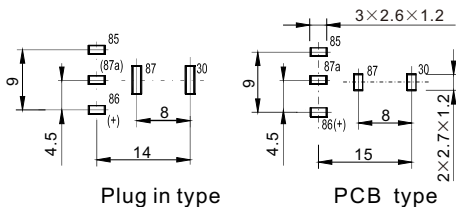

Plug in type

PCB type

Mounting (Bottom view)

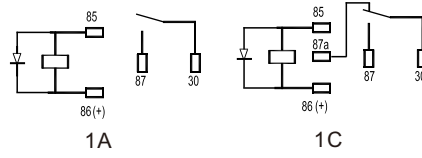

1A

1C

Wiring diagram (Bottom view)

CAUTION: 1) It is based on customer demand to have lead pin hole or not.

2) In case of no tolerance shown in outline dimension: outline dimension ≤1mm, tolerance should be ±0.2mm ;
outline dimension >1mm and ≤5mm, tolerance should be ±0.3mm; outline dimension >5mm, tolerance should be ±0.4mm.

Reference Data

