

NT90 (T90)

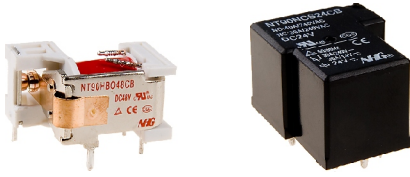

30.5 × 24.2 × 17 32.5 × 27.6 × 20.5

40040563

E174722

R50126373

Features

- Small size, light weight.
- Low coil power consumption, heavy contact load.
- Strong anti-shock and anti-vibration, high reliability, long life.
- PC board mounting.
- Suitable for automobile, machine, electronic equipment, air conditioner and household appliances applications.

Ordering Information

NT90 R H A S 12 C B 0.9
 1 2 3 4 5 6 7 8 9

1 Part number: NT90	6 Coil rated voltage(V): AC:12,24,110,120,220,240,277
2 Terminal: R: without Pin6; NIL: With Pin6	DC:3,5,6,9,12,15,18,24,48,110
3 Load: H:30A; N:40A	7 Contact material: S: AgSnO ₂ ; C:AgCdO
4 Contact arrangement: A:1A; B:1B; C:1C	8 Resist heatclass: B:130°C F:155°C
5 Enclosure: S: Wash tight; D: Dust protected; E: Flux proof; O: Unenclsd	9 Coil power: 0.6:0.6W; 0.9:0.9W; 2:2VA

Contact Data

Contact Arrangement	1A(SPSTNO) 1B(SPSTNC) 1C(SPDT(B-M))
Contact Material	AgSnO ₂ AgCdO
Contact Rating (Resistive)	NO:30A/240VAC,14VDC; NC:20A/240VAC;30A/14VDC NO:40A/240VAC,30VDC; NC:30A/240VAC,30VDC (0.9W) NO:30A/277VAC;NC:20A/277VAC Motor Load: NO:2HP 250VAC; NC:1.5HP 250VAC TV-5 5A/280VAC(Ballast)
Max. Switching Power	1200W 7200VA (10000VA)
Max. Switching Voltage	30VDC 280C Max. Switching Current:40A
Contact Resistance	≤ 30mΩ Item 4.12 of IEC 61810-7
Operation	Electrical 1×10 ⁵ Item 4.30 of IEC 61810-7
Life	Mechanical 1×10 ⁷ Item 4.31 of IEC 61810-7

Coil Parameter

AC Coil Parameter									
Dash numbers	Rated voltage VDC		Rated current mA	Coil resistance Ω ±10%	Pick-up voltage VAC(max) (75%of rated voltage)	Drop-out voltage VAC(min) (30%of rated voltage)	Coil power VA	Operate time ms	Release time ms
	Rated	Max							
012AC	12	15.6	166.6	27	9.0	3.6	2VA	—	—
024AC	24	31.2	83.3	120	18.0	7.2			
110AC	110	143	18.1	2360	82.5	33.0			
120AC	120	156	16.6	3040	90.0	36.0			
220AC	220	286	9.1	13490	165.0	66.0			
240AC	240	312	8.3	15740	180	72			
277AC	277	360.1	7.2	20300	207.8	83.1			

CAUTION: 1.The use of any coil voltage less than the rated coil voltage will compromise the operation of the relay.
 2.Pickup and release voltage are for test purposes only and are not to be used as design criteria.

Coil Parameter

DC Coil Parameter								
Dash numbers	Rated voltage V		Coil resistance $\Omega \pm 10\%$	Pick-up voltage V(max) (75%of rated voltage)	Drop-out voltage V(min) (10%of rated voltage)	Coil power W	Operate Time ms	Release Time ms
	Rated	Max						
003-900	3	3.9	10	2.25	0.3	0.9	≤ 15	≤ 10
005-900	5	6.5	28	3.75	0.5			
006-900	6	7.8	40	4.50	0.6			
009-900	9	11.7	90	6.75	0.9			
012-900	12	15.6	160	9.00	1.2			
015-900	15	19.5	250	10.25	1.5			
018-900	18	23.4	360	13.50	1.8			
024-900	24	31.2	640	18.00	2.4			
048-900	48	62.4	2560	36.00	4.8			
110-900	110	143	13445	82.50	11.0			
003-600	3	3.9	15	2.25	0.3	0.6	≤ 15	≤ 10
005-600	5	6.5	42	3.75	0.5			
006-600	6	7.8	60	4.50	0.6			
009-600	9	11.7	135	6.75	0.9			
012-600	12	15.6	240	9.00	1.2			
015-600	15	19.5	375	10.25	1.5			
018-600	18	23.4	540	13.50	1.8			
024-600	24	31.2	960	18.00	2.4			
048-600	48	62.4	3840	36.00	4.8			
110-600	110	143	20167	82.50	11.0			

CAUTION: 1.The use of any coil voltage less than the rated coil voltage will compromise the operation of the relay.
2.Pickup and release voltage are for test purposes only and are not to be used as design criteria.

Characteristics

Insulation Resistance	1000M Ω min (at 500VDC)	Item 4.11 of IEC 61810-7
Dielectric Strength Between Contacts	50Hz 1500V	Item 4.9 of IEC 61810-7
Between Contact and Coil	50Hz 2500V 4000V (Without Pin 6) *	Item 4.9 of IEC 61810-7
Shock Resistance	Functional:98m/s ² 11ms	Item 4.26 of IEC 61810-7
	Destructive:980m/s ² 11ms	Item 4.26 of IEC 61810-7
Vibration Resistance	10Hz~55Hz Double amplitude 1.5mm	Item 4.28 of IEC 61810-7
Terminals Strength	10N	Item 4.24 of IEC 61810-7
Ambient Temperature	-55 $^{\circ}$ C~85 $^{\circ}$ C	
Relative Humidity	5% to 85%	Item 4.16 of IEC 61810-7
Mass	25.7g(Unenclosed) 27g	Item 4.7 of IEC 61810-7

* Please contact the sales representative if 4000V is required.

Safety Approvals

Safety approval	UL&CUR	TüV	VDE
Load	NO:40A/240VAC;30A/277VAC NC:30A/240VAC,30VDC;20A/277VAC 5A/280VAC (Ballast) TV-5 NO:2 HP 250VAC A: 1HP/16AFLA/120VAC 2HP/12AFLA/240VAC NC: 1 $\frac{1}{2}$ HP 250VAC B: 30LRA/10AFLA/120VAC 30LRA/10AFLA/240VAC	NO:40A/240VAC,14VDC 30A/277VAC NC:30A/240VAC,14VDC 20A/277VAC	25A/250VAC

Dimensions

mm

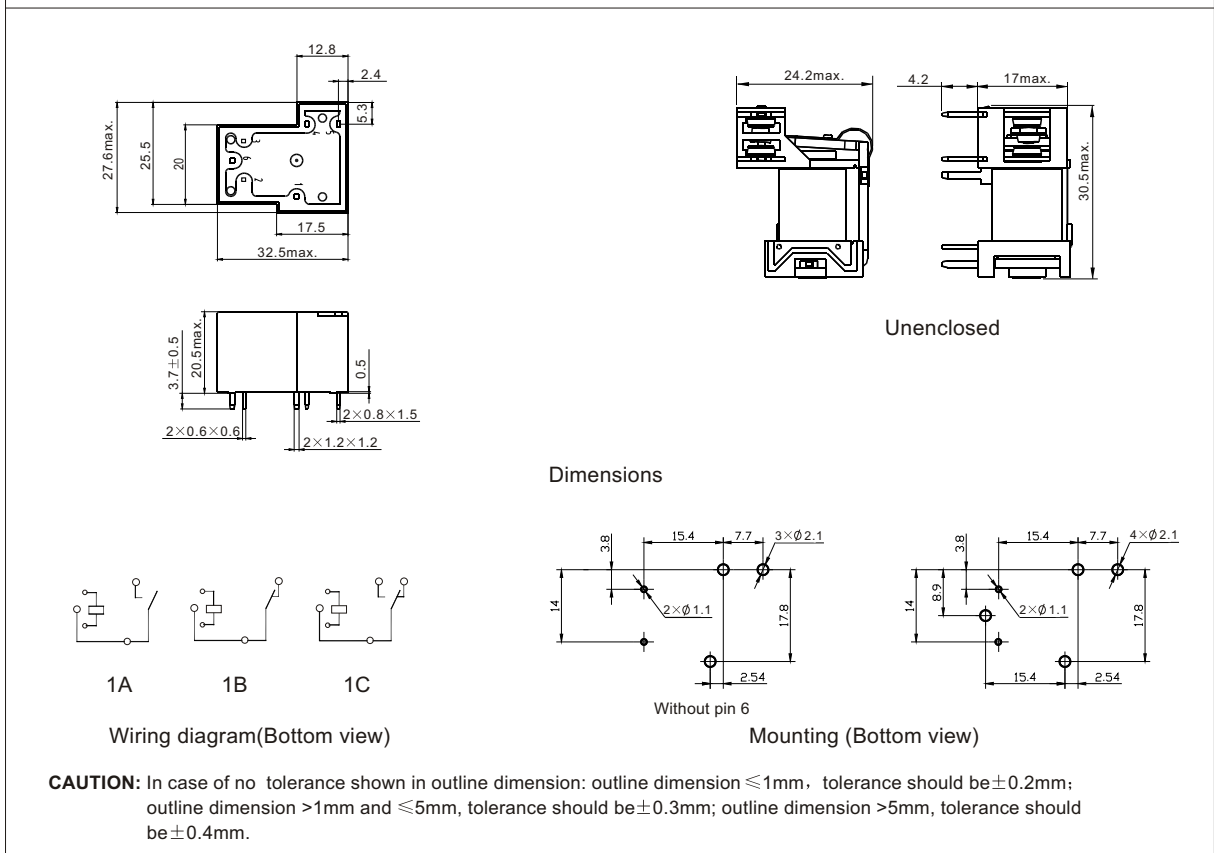

Reference Data

