

GES-40 / GES-55

技术参数/ TECHNICAL DATA	GES-40	GES-55
剪切力 Cutting force:	60KN	120KN
行程 Stroke:	40mm	50mm
剪切次数 Cutting times:	130times (饱和电压 Per saturation voltage)	70times (饱和电压 Per saturation voltage)
剪切范围 Cutting range:	Φ35mm _{max} 钢芯铝绞线 ACSR stranded wire	Φ50mm _{max} 铜/铝/铠装电缆/钢芯铝绞线 Armoured and Cu/Al cable/ACSR stranded wire
充电器电压 Charger voltage:	100-240VAC	100-240VAC
电池电压/容量 Voltage/capacity:	18V/4.0Ah	18V/4.0Ah
净重 Net weight:	3.0kg	6.0kg
充电时间 Charging time:	2 hours	2 hours
包装 Package:	塑料盒 Plastic box	塑料盒 Plastic box
配件 ACCESSORIES		
电池 Battery:	2pcs	2pcs
充电器 Charger:	1pc	1pc



GES-300C-2 / GE-300C-2

技术参数/ TECHNICAL DATA	GES-300C-2 / GE-300C-2
剪切力 Cutting force:	60KN
行程 Stroke:	17mm
剪切次数 Cutting times:	130times (饱和电压 Per saturation voltage)
剪切范围 Cutting range:	Φ30mm _{max} 铜/铝和铠装电缆 Armoured and Cu/Al cable
压接范围 Crimping range:	4-300mm ²
充电器电压 Charger voltage:	100-240VAC
电池电压/容量 Voltage/capacity:	18V/4.0Ah
净重 Net weight:	3.0kg
充电时间 Charging time:	2 hours
包装 Package:	塑料盒 Plastic box
配件 ACCESSORIES	
电池 Battery:	2pcs
充电器 Charger:	1pc



GES-300C-1 / GE-300C-1

技术参数/ TECHNICAL DATA	GES-300C-1 / GE-300C-1
剪切力 Cutting force:	60KN
行程 Stroke:	17mm
剪切次数 Cutting times:	130times (饱和电压 Per saturation voltage)
剪切范围 Cutting range:	Φ30mm _{max} 铜/铝和铠装电缆 Armoured and Cu/Al cable
压接范围 Crimping range:	16-300mm ²
充电器电压 Charger voltage:	100-240VAC
电池电压/容量 Voltage/capacity:	18V/4.0Ah
净重 Net weight:	3.0kg
充电时间 Charging time:	2 hours
包装 Package:	塑料盒 Plastic box
配件 ACCESSORIES	
电池 Battery:	2pcs
充电器 Charger:	1pc



REMOTE CONTROL CHARGING TYPE HYDRAULIC CABLE CUTTER

GES-50CY (遥控功能款 / 蓝牙功能款 可选)

技术参数 / TECHNICAL DATA	GES-50CY
剪切力 Cutting force:	60KN
行程 Stroke:	35mm
剪切次数 Cutting times:	130times (饱和电压 Per saturation voltage)
剪切范围 Cutting range:	Φ50mm _{max} 铜/铝/铠装电缆/钢芯铝绞线 Armoured and Cu/Al cable/ACSR stranded wire
充电器电压 Charger voltage:	100-240VAC
电池电压/容量 Voltage/capacity:	18V/4.0Ah
净重 Net weight:	5.0kg
充电时间 Charging time:	2 hours
包装 Package:	塑料盒 Plastic box
配件 ACCESSORIES	
电池 Battery:	2pcs
充电器 Charger:	1pc
遥控器 Remote control	2pcs
抱箍 Hoop	1set
绝缘杆 Insulated rod	4.5/6米可选



蓝牙APP远程控制



遥控器控制



充电式液压遥控线缆剪

CHARGING TYPE HYDRAULIC REMOTE CONTROL CABLE CUTTER

GES-32CY (遥控功能款 / 蓝牙功能款 可选)

技术参数 / TECHNICAL DATA	GES-32CY
剪切力 Cutting force:	60KN
行程 Stroke:	30mm
剪切次数 Cutting times:	130times (饱和电压 Per saturation voltage)
剪切范围 Cutting range:	Φ30mm _{max} 铜/铝/铠装电缆/钢芯铝绞线 Armoured and Cu/Al cable/ACSR stranded wire
充电器电压 Charger voltage:	100-240VAC
电池电压/容量 Voltage/capacity:	18V/4.0Ah
净重 Net weight:	4.5kg
充电时间 Charging time:	2 hours
包装 Package:	塑料盒 Plastic box
配件 ACCESSORIES	
电池 Battery:	2pcs
充电器 Charger:	1pc
遥控器 Remote control	2pcs
抱箍 Hoop	1set
绝缘杆 Insulated rod	4.5/6米可选



蓝牙APP远程控制



遥控器控制



REMOTE CONTROL CHARGING TYPE HYDRAULIC CABLE CUTTER

EB-105Y (遥控功能款 / 蓝牙功能款 可选)

技术参数 / TECHNICAL DATA	EB-105Y
剪切力 Cutting force:	120KN
行程 Stroke:	105mm
剪切次数 Cutting times:	130times (饱和电压 Per saturation voltage)
剪切范围 Cutting range:	Φ95mm _{max} 铜/铝和铠装电缆 Armoured and Cu/Al cable
电池电压/容量 Voltage/capacity:	18V/4.0Ah
净重 Net weight:	6.5kg
充电时间 Charging time:	2 hours
包装 Package:	塑料盒 Plastic box
配件 ACCESSORIES	
电池 Battery:	2pcs
充电器 Charger:	1pc
遥控器 Remote control	2pcs
抱箍 Hoop	1set
接地杆导线 Grounding rod conductor	4.5/6米可选



25吨 EB-120CY (遥控功能款 / 蓝牙功能款 可选)

技术参数 / TECHNICAL DATA	25吨 EB-120CY
剪切力 Cutting force:	150KN
行程 Stroke:	62mm
剪切次数 Cutting times:	50times (饱和电压 Per saturation voltage)
剪切范围 Cutting range:	Φ100mm _{max} 铜/铝和铠装电缆 Armoured and Cu/Al cable
电池电压/容量 Voltage/capacity:	18V/4.0Ah
毛重/净重 Gross weight/Net weight:	19kg/9kg
充电时间 Charging time:	2 hours
包装 Package:	塑料盒 Plastic box
配件 ACCESSORIES	
电池 Battery:	2pcs
充电器 Charger:	1pc
遥控器 Remote control	2pcs
抱箍 Hoop	1set
接地杆导线 Grounding rod conductor	4.5/6米可选



EBS-2000B/135C 背包式电动遥控剪刀
(遥控功能款 / 蓝牙功能款 可选)

技术参数 / TECHNICAL DATA	EBS-2000B/135C
剪切力 Cutting force:	200KN
行程 Stroke:	62mm
剪切次数 Cutting times:	40times (饱和电压 Per saturation voltage)
剪切范围 Cutting range:	Φ130mm _{max} 铜/铝和铠装电缆 Armoured and Cu/Al cable
电池电压/容量 Voltage/capacity:	18V/5.0Ah/9.0Ah可选
毛重/净重 Gross weight/Net weight:	24kg/11kg
充电时间 Charging time:	2 hours
包装 Package:	塑料盒 Plastic box
配件 ACCESSORIES	
电池 Battery:	2pcs
充电器 Charger:	1pc
遥控器 Remote control	2pcs
抱箍 Hoop	1set
接地杆导线 Grounding rod conductor	4.5/6米可选



备注：可选各种分体剪刀头

RATCHET CHARGING TYPE HYDRAULIC CABLE CUTTER

EMS-50

技术参数 / TECHNICAL DATA	EMS-50
剪切次数 Cutting times:	130times (饱和电压 Per saturation voltage)
剪切范围 Cutting range:	Φ50mmmax 铜/铝/铠装电缆/钢芯铝绞线 Armoured and Cu/Al cable/ACSR stranded wire
充电器电压 Charger voltage:	100-240VAC
电池电压/容量 Voltage/capacity:	18V/4.0Ah
净重 Net weight:	4.0kg
充电时间 Charging time:	2 hours
包装 Package:	塑料盒 Plastic box
配件 ACCESSORIES	
电池 Battery:	2pcs
充电器 Charger:	1pc



EMS-60

技术参数 / TECHNICAL DATA	EMS-60
剪切次数 Cutting times:	130times (饱和电压 Per saturation voltage)
剪切范围 Cutting range:	Φ60mmmax 铜/铝和铠装电缆 Armoured and Cu/Al cable
充电器电压 Charger voltage:	100-240VAC
电池电压/容量 Voltage/capacity:	18V/4.0Ah
净重 Net weight:	4.0kg
充电时间 Charging time:	2 hours
包装 Package:	塑料盒 Plastic box
配件 ACCESSORIES	
电池 Battery:	2pcs
充电器 Charger:	1pc



EMS-85

技术参数 / TECHNICAL DATA	EMS-85
剪切次数 Cutting times:	130times (饱和电压 Per saturation voltage)
剪切范围 Cutting range:	Φ85mmmax 铜/铝和铠装电缆 Armoured and Cu/Al cable
充电器电压 Charger voltage:	100-240VAC
电池电压/容量 Voltage/capacity:	18V/4.0Ah
净重 Net weight:	4.0kg
充电时间 Charging time:	2 hours
包装 Package:	塑料盒 Plastic box
配件 ACCESSORIES	
电池 Battery:	2pcs
充电器 Charger:	1pc



135CTG CHARGING TYPE HYDRAULIC IRON PIPE SPECIAL CUTTER

25吨DES-135CTG (无刷驱动)

25吨EBS-135CTG



技术参数 / TECHNICAL DATA

剪切力 Cutting force:	200KN
行程 Stroke:	62mm
剪切次数 Cutting times:	40times (饱和电压 Per saturation voltage) (4.0标配)
剪切范围 Cutting range:	84mm Φ100mm _{max}
电池电压/容量 Voltage/capacity:	18V/4.0Ah/9.0Ah
净重 Net weight:	11kg
充电时间 Charging time:	2 hours
包装 Package:	塑料盒 Plastic box
配件 ACCESSORIES	
电池 Battery:	2pcs
充电器 Charger:	1pc



120CTG CHARGING TYPE HYDRAULIC IRON PIPE SPECIAL CUTTER

25吨DES-120CTG (无刷驱动)



连续剪切功能型
With continuous function

25吨EBS-120CTG



连续剪切功能型
With continuous function

技术参数 / TECHNICAL DATA

剪切力 Cutting force:	200KN
行程 Stroke:	62mm
剪切次数 Cutting times:	50times (饱和电压 Per saturation voltage)
剪切范围 Cutting range:	δ4mm Φ80mm _{max}
电池电压/容量 Voltage/capacity:	18V/4.0Ah/9.0Ah
净重 Net weight:	10kg
充电时间 Charging time:	2 hours
包装 Package:	塑料盒 Plastic box
配件 ACCESSORIES	
电池 Battery:	2pcs
充电器 Charger:	1pc



120CTG CHARGING TYPE HYDRAULIC IRON PIPE SPECIAL CUTTER

15吨DES-120CTG (无刷驱动)



连续压接功能型
With continuous function

15吨EBS-120CTG



连续压接功能型
With continuous function

技术参数 / TECHNICAL DATA

剪切力 Cutting force:	150KN
行程 Stroke:	62mm
剪切次数 Cutting times:	50times (饱和电压 Per saturation voltage) (4.0标配)
剪切范围 Cutting range:	δ3mm Φ80mm _{max}
电池电压/容量 Voltage/capacity:	18V/4.0Ah/9.0Ah
净重 Net weight:	10kg
充电时间 Charging time:	2 hours
包装 Package:	塑料盒 Plastic box
配件 ACCESSORIES	
电池 Battery:	2pcs
充电器 Charger:	1pc



105CTG CHARGING TYPE HYDRAULIC IRON PIPE SPECIAL CUTTER

25吨DES-105CTG (无刷驱动)



连续剪切功能型
With continuous function

25吨EBS-105CTG



连续剪切功能型
With continuous function

技术参数 / TECHNICAL DATA

剪切力 Cutting force:	200KN
行程 Stroke:	62mm
剪切次数 Cutting times:	70times (饱和电压 Per saturation voltage) (4.0标配)
剪切范围 Cutting range:	δ4mm Φ60mm _{max}
电池电压/容量 Voltage/capacity:	18V/4.0Ah/9.0Ah
净重 Net weight:	9kg
充电时间 Charging time:	2 hours
包装 Package:	塑料盒 Plastic box
配件 ACCESSORIES	
电池 Battery:	2pcs
充电器 Charger:	1pc



充电式液压铁管专用剪刀

CHARGING TYPE HYDRAULIC IRON PIPE SPECIAL CUTTER

105CTG CHARGING TYPE HYDRAULIC IRON PIPE SPECIAL CUTTER

15吨DES-105CTG (无刷驱动)



15吨EBS-105CTG



充电式液压铁管专用剪刀

CHARGING TYPE HYDRAULIC IRON PIPE SPECIAL CUTTER

技术参数 / TECHNICAL DATA

剪切力 Cutting force:	150KN
行程 Stroke:	62mm
剪切次数 Cutting times:	70times (饱和电压 Per saturation voltage) (4.0标配)
剪切范围 Cutting range:	63mm Φ60mm _{max}
电池电压/容量 Voltage/capacity:	18V/4.0Ah/9.0Ah
净重 Net weight:	9kg
充电时间 Charging time:	2 hours
包装 Package:	塑料盒 Plastic box
配件 ACCESSORIES	
电池 Battery:	2pcs
充电器 Charger:	1pc



MANUAL HYDRAULIC CABLE CUTTER

THC-45

内部有安全系统
With safety system inside



技术参数/ TECHNICAL DATA	THC-45
剪切力 Cutting force:	60KN
剪切范围 Cutting range:	Φ45mm (铜/铝和铠装电缆Armoured and Cu/Al cable)
行程 Stroke:	50mm
长度 Length:	560mm
重量 Weight:	4.8kg
包装 Package:	钢制外壳 steel case
箱子重量 Weight of case:	3.3kg
配件 ACCESSORIES:	
注: 如换刀可切Φ38mm ACSR/Φ28钢丝 Note: If change knife can cut Φ38mm ACSR/Φ28 steel wire	

- 翻转式切割头旋转350°。
- 两级液压, 减少切割周期, 切割完成后自动释放压力。
- 需要时手动释放。
- Flip top cutting head rotates 350°.
- Two stage hydraulic to reduce cutting cycle, automatic release pressure when cut is complete.
- Manual release in case of need.

THC-85

内部有安全系统
With safety system inside

技术参数/ TECHNICAL DATA	THC-85
剪切力 Cutting force:	60KN
剪切范围 Cutting range:	Φ85mm (铜/铝和铠装电缆Armoured and Cu/Al cable)
行程 Stroke:	86mm
长度 Length:	680mm
重量 Weight:	7.6kg
包装 Package:	钢制外壳 steel case
箱子重量 Weight of case:	3.8kg



CPC-50



技术参数 / TECHNICAL DATA	CPC-50
剪切力 Cutting force:	60KN
剪切范围 Cutting range:	Φ40mm _{max} 电话线 for telephone cable Φ32mm _{max} 铠装铜/铝电缆 for armoured Cu/Al cable
行程 Stroke:	48mm
长度 Length:	580mm
重量 Weight:	5.2kg
包装 Package:	钢制外壳 steel case
箱子重量 Weight of case:	3.25kg

CPC-85



技术参数 / TECHNICAL DATA	CPC-85
剪切力 Cutting force:	60KN
剪切范围 Cutting range:	Φ50mm _{max} 电话线 for telephone cable Φ45mm _{max} 铠装铜/铝电缆 for armoured Cu/Al cable
行程 Stroke:	65mm
长度 Length:	630mm
重量 Weight:	7.1kg
包装 Package:	钢制外壳 steel case
箱子重量 Weight of case:	3.5kg

CPC-105



技术参数 / TECHNICAL DATA	CPC-105
剪切力 Cutting force:	60KN
剪切范围 Cutting range:	Φ40mm _{max} 电话线 for telephone cable Φ28mm _{max} 铠装铜/铝电缆 for armoured Cu/Al cable
行程 Stroke:	42mm
长度 Length:	600mm
重量 Weight:	5.6kg
包装 Package:	钢制外壳 steel case
箱子重量 Weight of case:	3.3kg

RATCHET MANUAL HYDRAULIC CABLE CUTTER

J13 棘轮钢绞线电缆剪
Ratchet cable cutter



净重: 约1.9kg
Net weight: about 1.9kg

尺寸: 345(伸长514)×125×46mm
Size: 345 (extended 514)×125×46mm

剪切范围 Cutting range:
剪断720mm²以下钢芯铝绞线
It can cut the steel core aluminum stranded wire below 720mm²



剪断150mm²以下钢绞线
It can cut steel strands below 150mm²



✗ 严禁剪切钢铝线
It is strictly forbidden to cut steel and aluminum wires.

小提示: 刃口可重复打磨使用
Tips: The cutting edge can be used repeatedly.

J25 棘轮钢绞线电缆剪
Ratchet cable cutter



净重: 约2.8kg
Net weight: about 2.8kg

尺寸: 565(伸长745)×130×60mm
Size: 565 (extended 745)×130×60mm

剪切范围 Cutting range:
剪断800mm²以下钢芯铝绞线
It can cut the steel core aluminum stranded wire below 800mm²



剪断150mm²以下钢绞线
It can cut steel strands below 150mm²



✗ 严禁剪切钢铝线
It is strictly forbidden to cut steel and aluminum wires.

小提示: 刃口可重复打磨使用
Tips: The cutting edge can be used repeatedly.

J30 棘轮钢绞线电缆剪
Ratchet cable cutter



净重: 约3.4kg
Net weight: about 3.4kg

尺寸: 406(伸长514)×160×64mm
Size: 406 (extended 514)×160×64mm

剪切范围 Cutting range:
剪断630mm²以下钢芯铝绞线
It can cut the steel core aluminum stranded wire below 630mm²



剪断150mm²以下钢绞线
It can cut steel strands below 150mm²



✗ 严禁剪切铠装电缆、钢铝电缆、钢丝绳
It is strictly forbidden to cut armored cables, steel and aluminum cables, and steel wire ropes.

小提示: 刃口可重复打磨使用
Tips: The cutting edge can be used repeatedly.

J50 棘轮钢绞线电缆剪
Ratchet cable cutter



净重: 约3.2kg
Net weight: about 3.2kg

尺寸: 400(伸长568)×158×52mm
Size: 400 (extended 568)×158×52mm

剪切范围 Cutting range:
剪断1440mm²以下钢芯铝绞线
It can cut the steel core aluminum stranded wire below 1440mm²



剪断240mm²以下钢绞线
It can cut steel strands below 240mm²



✗ 严禁剪切铠装电缆、钢铝电缆、钢丝绳
It is strictly forbidden to cut armored cables, steel and aluminum cables, and steel wire ropes.

小提示: 刃口可重复打磨使用
Tips: The cutting edge can be used repeatedly.

J40 棘轮铜铝芯铠装电缆剪
Armoured & Cu/Al ratchet cable cutter



净重: 约1.15kg
Net weight: about 1.15kg

尺寸: 346(伸长568)×120×38mm
Size: 346 (extended 568) × 120 × 38mm

剪切范围 Cutting range:
剪断300mm²以下铠装电缆
It can cut the armored cable below 300m²



剪断300mm²以下铜铝电缆
It can cut the Cu/Al cable below 300mm²



❌ 严禁剪切钢绞线钢芯铝绞线及各种钢性电缆
It is forbidden to cut steel strand, ACSR and other steel cables.

小提示: 刃口可重复打磨使用
Tips: The cutting edge can be used repeatedly.

J52 棘轮铜铝芯铠装电缆剪
Armoured & Cu/Al ratchet cable cutter



净重: 约2.9kg Net weight: about 2.9kg

尺寸: 397(伸长568)×165×54mm
Size: 397 (extended 568) × 165 × 54mm

剪切范围 Cutting range:
剪断Φ50mm以下铠装电缆
It can cut the armored cable below Φ50mm



剪断Φ50mm以下铜铝电缆
It can cut the Cu/Al cable below Φ50mm



❌ 严禁剪切钢绞线钢芯铝绞线及各种钢性电缆
It is forbidden to cut steel strand, ACSR and other steel cables.

小提示: 刃口可重复打磨使用
Tips: The cutting edge can be used repeatedly.

J75 棘轮铜铝芯铠装电缆剪
Armoured & Cu/Al ratchet cable cutter



净重: 约3.6kg
Net weight: about 3.6kg

尺寸: 416(伸长587)×200×55mm
Size: 416 (extended 587) × 200 × 55mm

剪切范围 Cutting range:
剪断Φ75mm以下铜铝芯铠装电缆
It can cut the armored and Cu/Al cable below Φ75mm²



剪断3×12通信电缆
It can cut 3×12 communication cable



❌ 严禁剪切钢绞线钢芯铝绞线及各种钢性电缆
It is forbidden to cut steel strand, ACSR and other steel cables.

小提示: 刃口可重复打磨使用
Tips: The cutting edge can be used repeatedly.

J95 棘轮铜铝芯铠装电缆剪
Armoured & Cu/Al ratchet cable cutter



净重: 约5.7kg Net weight: about 5.7kg

尺寸: 416(伸长587)×200×55mm
Size: 416 (extended 587) × 200 × 55mm

剪切范围 Cutting range:
剪断3×185mm²或Φ90mm以下铜铝芯铠装电缆
It can cut the copper aluminum core armored cable below 3×185mm² or Φ90mm



❌ 严禁剪切钢绞线钢芯铝绞线及各种钢性电缆
It is forbidden to cut steel strand, ACSR and other steel cables.

小提示: 刃口可重复打磨使用
Tips: The cutting edge can be used repeatedly.

J100 棘轮铜铝芯铠装电缆剪
Armoured & Cu/Al cable cutter



净重: 约6.25kg Net weight: about 6.25kg

尺寸: 482(伸长655)×270×59mm
Size: 482 (extended 655) × 270 × 59mm

剪切范围 Cutting range:
剪断3×300mm²或Φ100mm以下铜铝芯铠装电缆
It can cut the copper aluminum core armored cable below 3×300mm² or Φ100mm



❌ 严禁剪切钢绞线钢芯铝绞线及各种钢性电缆
It is forbidden to cut steel strand, ACSR and other steel cables.

小提示: 刃口可重复打磨使用
Tips: The cutting edge can be used repeatedly.

XLJ-100A 棘轮多功能电缆剪
Ratchet multifunctional cable cutter



净重: 约6.3kg Net weight: about 6.3kg

尺寸: 485(伸长655)×270×59mm
Size: 485(extended 655)×270×59mm

剪切范围 Cutting range:
剪断3×300mm²及Φ100mm以下多芯铜铝
铠装电缆
It can cut off the multi-core Cu/Al armored cable
with diameter less than 100mm and 3×300mm²



⊗ 严禁剪切钢绞线钢芯铝绞线及各种钢性电缆
It is forbidden to cut steel strand, ACSR
and other steel cables.

小提示: 刃口可重复打磨使用
Tips: The cutting edge can be used repeatedly.

XLJ-120A 棘轮多功能电缆剪
Ratchet multifunctional cable cutter



净重: 约10kg Net weight: about 10kg

尺寸: 540(伸长710)×325×80mm
Size: 540(extended 710)×325×80mm

剪切范围 Cutting range:
剪断120mm及以下多芯铜铝铠装电缆
It can cut the multi-core copper aluminum armored
cable with the diameter of 120mm and below



⊗ 严禁剪切钢绞线钢芯铝绞线及各种钢性电缆
It is forbidden to cut steel strand, ACSR
and other steel cables.

小提示: 刃口可重复打磨使用
Tips: The cutting edge can be used repeatedly.

XLJ-D-300 棘轮多功能电缆剪
Ratchet multifunctional cable cutter



净重: 约1.1kg Net weight: about 1.1kg

尺寸: 240×130×47mm
Size: 240×130×47mm

剪切范围 Cutting range:
剪断单芯最大300mm²的铜铝线纜
或Φ30mm的铜铝线纜
It can cut the single core Cu/Al cable with a
maximum of 300mm² or Φ30mm Cu/Al cable



⊗ 严禁剪切钢绞线钢芯铝绞线及各种钢性电缆
It is forbidden to cut steel strand, ACSR
and other steel cables.

小提示: 刃口可重复打磨使用
Tips: The cutting edge can be used repeatedly.

XLJ-D-500 棘轮多功能电缆剪
Ratchet multifunctional cable cutter



净重: 约1.2kg Net weight: about 1.2kg

尺寸: 240×130×47mm
Size: 240×130×47mm

剪切范围 Cutting range:
剪断单芯最大500mm²的铜铝线纜
或Φ50mm的铜铝线纜
It can cut the single core Cu/Al cable with a
maximum of 500mm² or Φ50mm Cu/Al cable



⊗ 严禁剪切钢绞线钢芯铝绞线及各种钢性电缆
It is forbidden to cut steel strand, ACSR
and other steel cables.

小提示: 刃口可重复打磨使用
Tips: The cutting edge can be used repeatedly.

XD-520A 棘轮多功能电缆剪
Ratchet multifunctional cable cutter



净重: 约1.9kg Net weight: about 1.9kg

尺寸: 310(伸长420)×140×55mm
Size: 310(extended 420)×140×55mm

剪切范围 Cutting range:
剪断630mm²以下钢芯铝绞线
Φ32mm以下钢芯电缆
100mm²以下钢绞线
Φ10mm以下钢筋的切断
Φ6-16m钢丝绳的切断

小提示: 刃口可重复打磨使用
Tips: The cutting edge can be used repeatedly.

ZC-G32A



铜/铝电缆
Cu/Al cable



铠装电缆
Armoured cable



钢芯铝绞线
ACSR

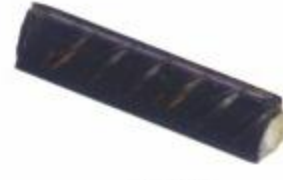

钢筋
Steel bar



技术参数 / TECHNICAL DATA

型号 Model No:	ZC-G32A
剪切范围 Cutting range:	最大100mm ² 钢绞线, 最大600mm 钢芯铝绞线, 最大Φ32mm钢芯电缆 Max.100mm ² steel stranded wire Max.600mm ACSR, Max. Φ32mm steel core cable
长度 Length:	350-480mm
重量 Weight:	2.0kg
包装 Package:	帆布包 canvas bag



可伸缩手柄



ZC-G40A



铜/铝电缆
Cu/Al cable



铠装电缆
Armoured cable



钢芯铝绞线
ACSR

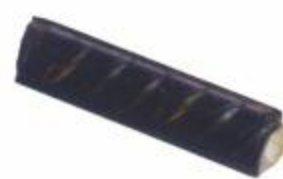

钢筋
Steel bar



技术参数 / TECHNICAL DATA

型号 Model No:	ZC-G40A
剪切范围 Cutting range:	最大Φ20mm钢绞线, 最大Φ36mm铜/铝电缆 Max.Φ20mm steel stranded wire Max.Φ36mm Cu/Al cable
长度 Length:	440-630mm
重量 Weight:	3.6kg
包装 Package:	帆布包 canvas bag



可伸缩手柄



ZC-G40



铜/铝电缆
Cu/Al cable



铠装电缆
Armoured cable



钢芯铝绞线
ACSR

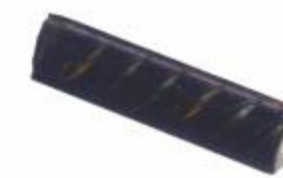

钢筋
Steel bar



技术参数 / TECHNICAL DATA

型号 Model No:	ZC-G40
剪切范围 Cutting range:	最大120mm ² 钢绞线, 最大800mm 钢芯铝绞线, 最大Φ36mm钢芯电缆 Max.120mm ² steel stranded wire Max.800mm ACSR, Max. Φ36mm steel core cable
长度 Length:	440-630mm
重量 Weight:	3.6kg
包装 Package:	帆布包 canvas bag



可伸缩手柄



ZC-70A

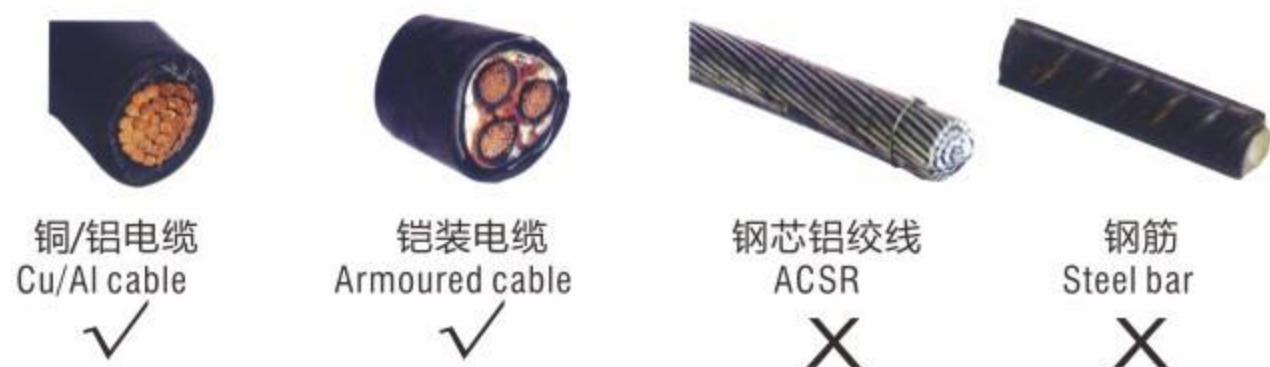

型号 Model No:	ZC-70A	
剪切范围 Cutting range:	最大Φ70mm 铜/铝铠装电缆	Max. Φ70mm Cu/Al armoured cable
长度 Length:	380-485mm	
重量 Weight:	3.2kg	
包装 Package:	帆布包 canvas bag	

ZC-95A

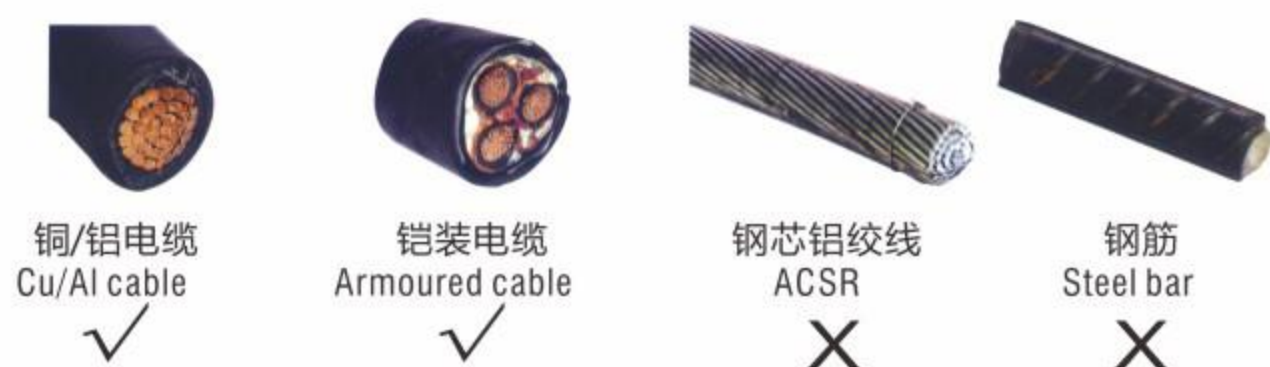

型号 Model No:	ZC-95A	
剪切范围 Cutting range:	最大Φ95mm 铜/铝铠装电缆	Max. Φ95mm Cu/Al armoured cable
长度 Length:	530-725mm	
重量 Weight:	6.3kg	
包装 Package:	帆布包 canvas bag	

ZC-120A

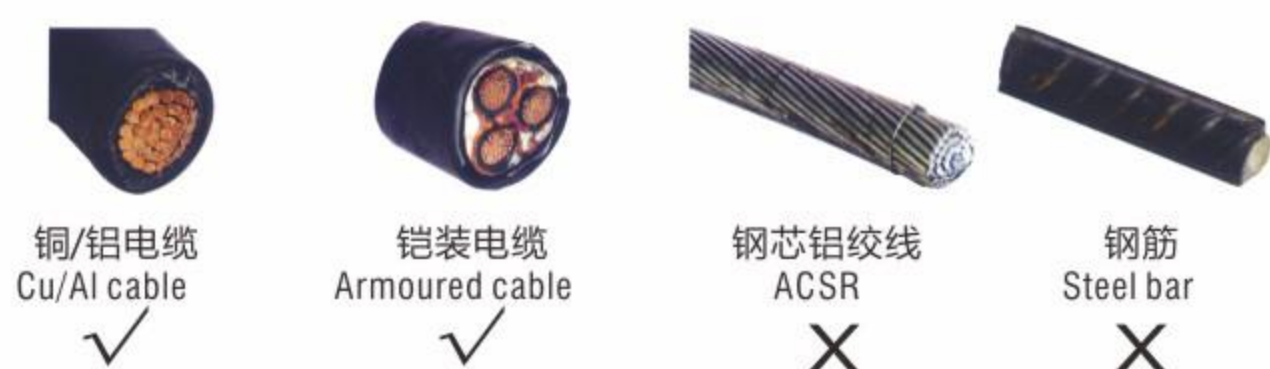

型号 Model No:	ZC-120A	
剪切范围 Cutting range:	最大Φ120mm 铜/铝铠装电缆	Max. Φ120mm Cu/Al armoured cable
长度 Length:	555-745mm	
重量 Weight:	7.0kg	
包装 Package:	帆布包 canvas bag	

ZC-160A

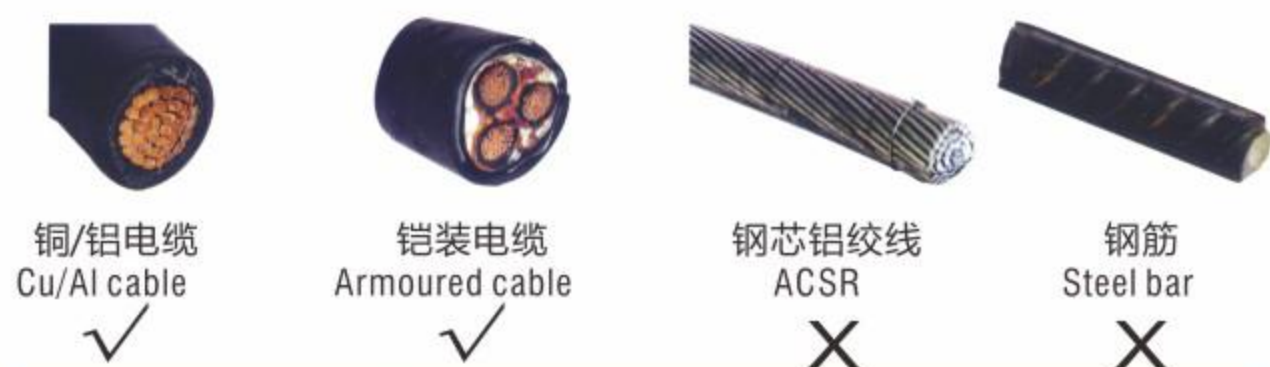

型号 Model No:	ZC-160A	
剪切范围 Cutting range:	最大Φ160mm 铜/铝铠装电缆	Max. Φ160mm Cu/Al armoured cable
长度 Length:	760-950mm	
重量 Weight:	9.5kg	
包装 Package:	帆布包 canvas bag	

刀是锻造而成，寿命长，易于切割。
The knives are made by forging, long life span and easy to cut.



可伸缩手柄



可伸缩手柄



可伸缩手柄



可伸缩手柄

LABOR-SAVING LONG ARM CABLE CUTTER

HS-125/LK-250/LK-500

省力长臂电缆剪
LABOR-SAVING LONG ARM CABLE CUTTER

- 用以剪切铜铝电缆，单股线和多股线
- 最优杠杆力矩传输和特殊几何形状刀片，确保只需施加较小的外力进行剪切
- 剪切头：高等级铬钒电工钢，油淬处理，可替换
- 手柄：铁管
- For cutting copper and aluminium conductors as well as multiple stranded cables
- Favourable transmission ratio due to double lever
- Blade: high-grade chrome vanadium electric steel, forged, oil-hardened, replaceable blades
- Handles material: Steel

专切铜铝导线、通讯电缆的工具，不能切断钢索、钢筋及铠装电缆。
For Cu/Al conductor and communication cable only.



HS-125

工具参数 TOOL PARAMETERS	
剪切能力 Cutting capacity	125 mm ²
长度 Length	385mm
重量(净重/毛重) Weight(Net weight/Gross weight)	0.71/0.81Kg



LK-250

工具参数 TOOL PARAMETERS	
剪切能力 Cutting capacity	250mm ²
长度 Length	560mm
重量(净重/毛重) Weight(Net weight/Gross weight)	1.66/1.86Kg



LK-500

工具参数 TOOL PARAMETERS	
剪切能力 Cutting capacity	500 mm ²
长度 Length	745mm
重量(净重/毛重) Weight(Net weight/Gross weight)	4.13/4.47Kg

CABLE STRIPPER

PG-5 电缆剥皮器 CABLE STRIPPER

- 用于直径 ≥ 25mm 的圆电缆剥皮，可完整剥除各种绝缘层
- 适用于纵向切割和环绕切割，切割深度最大可调整到 5mm
- 刀片可替换（两侧可以使用）
- For removing all layers of insulation on cables with diameters of over 25mm
- Suitable for longitudinal and circular cutting, Cutting depth can be adjusted from 0-5mm
- Replaceable blade (both sides can be used)

可应用于 Application



电讯电缆
Communication Cable

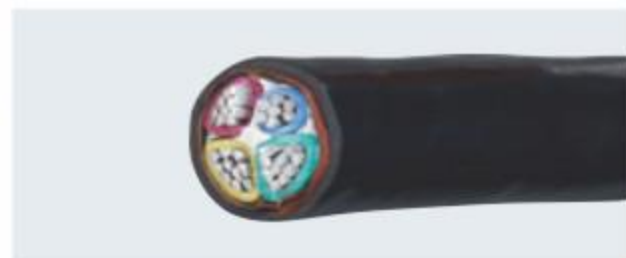

MV 电缆 (聚乙烯绝缘电线构造)
MV Cable(PVC Constructed)



LV 电缆(PVC 绝缘体构造)
LV Cable(PVC Insulation)



MV 电缆 (PVC 绝缘体构造)
MV Cable(PVC Insulation)



换刀片：取下调节螺丝，就可以更换双面刀片

Changing the blade:

By removing the adjusting screw, the double-ended blade can be changed.

工具参数 TOOL PARAMETERS

剥线能力 Stripping capacity	≥ Φ 25 mm
长度 Length	155 mm
重量(净重/毛重) Weight(Net weight/Gross weight)	0.2/0.24Kg



调整切割深度
Adjust cutting depth



设定工具纵向切割
Put the tool vertically



纵向切割
Cutting vertically



转动工具设定环绕切割
Rotate the tool and cutting around



环绕切割
Cutting finished

SK-40/SK-50 电缆剥皮器 CABLE STRIPPER

- 使用范围：该工具适用于低于 35kV 电缆绝缘层外层剥制
- 绝缘层的剥制工具由固定底座、活动座和固定支架组成
- 通过使用螺纹杠杆在活动的上部分中压紧刀片。通过附带的内六角扳手可以很轻松地将修理刀片安装在两个平面上
- 当工具沿着电缆轴顺时针转动时，工具会沿着电缆方向自动移动
- 可以使用调节螺纹杆进行调节
- Range of use: The tool is applicable for stripping the external insulation layer of cable less than 35kV.
- Operating instruction: The tool comprises of the base, the moving seat and the frame.
- The blade can be held in the moving upper part by the screw. And the repairing blade can be fixed on the two planes by the attached inner hexagon spanner easily.
- When the tool turns clockwise along cable, it can move automatically with the direction of cable.
- It can be adjusted by the adjusting screw.

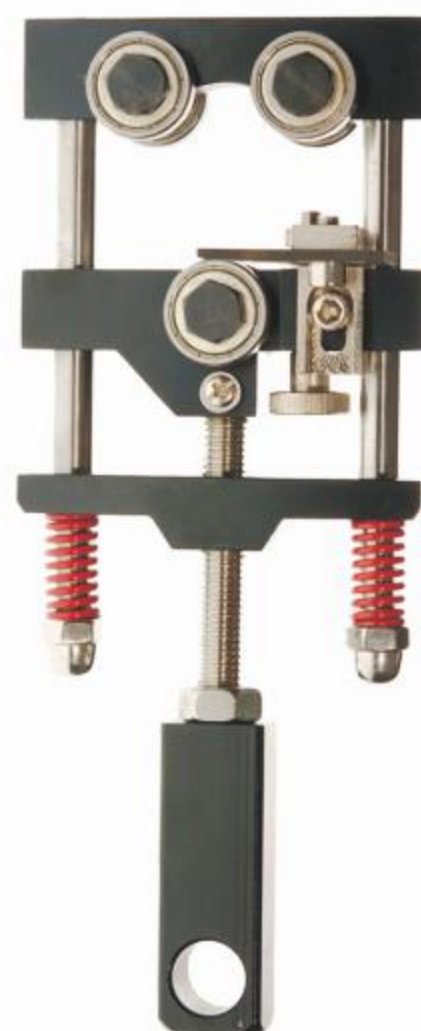
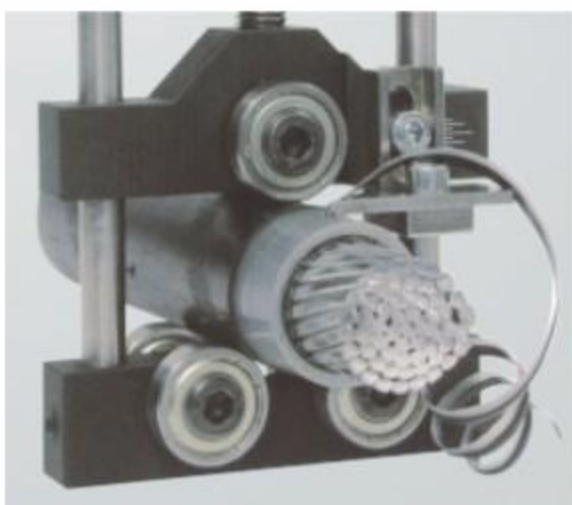

包装方式：塑料盒
Package: Plastic case

工具参数 TOOL PARAMETERS	SK-40	SK-50
剥线能力 Stripping capacity	Φ20-40 mm	Φ20-50 mm
长度 Length	250 mm	250 mm
重量(净重/毛重) Weight(Net weight/Gross weight)	1.06/1.15Kg	1.06/1.15Kg

BX-30 电缆剥皮器 CABLE STRIPPER

- 绝缘电线或电力电缆线芯末端和中段主绝缘层的剥除
- 切削厚度可根据需要调整
- Stripping of the main insulating layer at the end and middle section of insulated wire or power cable core.
- The cutting thickness can be adjusted as required.

工具参数 TOOL PARAMETERS	
剥线能力 Stripping capacity	Φ15-30 mm
尺寸 Size	280×75×50mm
重量(净重/毛重) Weight(Net weight/Gross weight)	0.68/0.83Kg



刀片不可触碰电缆的金属层作业，刀片磨损或损坏后可更换或修磨
The knives cannot touch the metal cable cores when stripping knives can be sharpened or replaced.

BX-40 电缆剥皮器 CABLE STRIPPER

- 绝缘电线或电力电缆线芯末端主绝缘层的剥除
Stripping of the main insulation layer at the end of the insulated wire or power cable core



工具参数 TOOL PARAMETERS	
剥线能力 Stripping capacity	Φ20-40 mm
尺寸 Size	245×87×55mm
重量(净重/毛重) Weight(Net weight/Gross weight)	0.8Kg

BX-90 电缆剥皮器 CABLE STRIPPER

- 高压电缆末端的剥除及削尖
Stripping and sharpening of high-voltage cable ends



工具参数 TOOL PARAMETERS	
剥线能力 Stripping capacity	Φ40-90 mm
尺寸 Size	490×140×75mm
重量(净重/毛重) Weight(Net weight/Gross weight)	2.5Kg

KBX-45 电缆剥皮器 CABLE STRIPPER

- 电缆绝缘层的剥除 Cable insulation stripping



工具参数 TOOL PARAMETERS	
剥线能力 Stripping capacity	Φ45 mm
尺寸 Size	245×80×90mm
重量(净重/毛重) Weight(Net weight/Gross weight)	0.8Kg

KBX-65 电缆剥皮器 CABLE STRIPPER

- 电缆绝缘层剥除 Cable insulation stripping

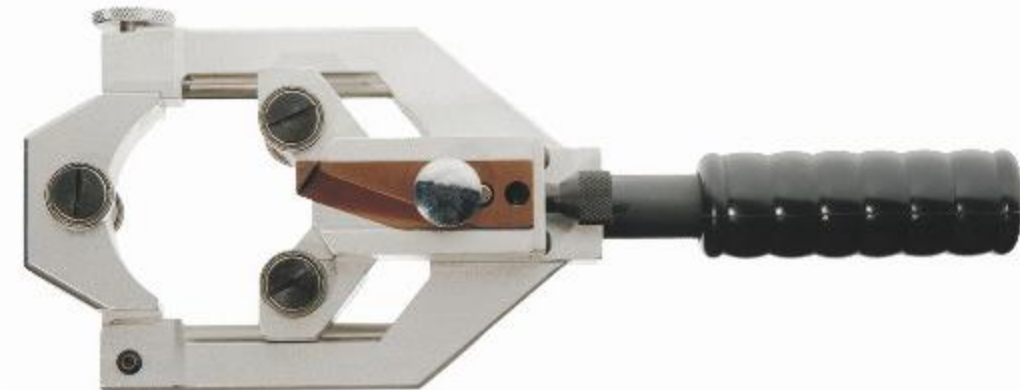

工具参数 TOOL PARAMETERS	
剥线能力 Stripping capacity	Φ65 mm
尺寸 Size	295×125×70mm
重量(净重/毛重) Weight(Net weight/Gross weight)	1.4Kg

LBX/CX121 电缆剥皮器 CABLE STRIPPER

- 厚度≤4.5mm电缆主绝缘层的剥除
Stripping of the main insulation layer of cables with a thickness of ≤4.5



工具参数 TOOL PARAMETERS	
剥线能力 Stripping capacity	Φ30mm
尺寸 Size	220×95×75mm
重量(净重/毛重) Weight(Net weight/Gross weight)	0.69/0.93Kg

SBX/CX119 电缆剥皮器 CABLE STRIPPER

- 架空绝缘电缆绝缘层的剥除
Stripping off the insulation of overhead insulated cables



工具参数 TOOL PARAMETERS	
剥线能力 Stripping capacity	35-300mm ²
尺寸 Size	240×180×90mm
重量(净重/毛重) Weight(Net weight/Gross weight)	0.5Kg

SC-85 / SC-105

产品特点

- 分体式液压电缆剪可与液压手动泵或电动液压泵配合使用，适用于大尺寸电话电缆或铠装Cu/Al电缆。

FEATURES:

- Split hydraulic cable cutter can work with hydraulic handpump or electric hydraulic pump, it is suit for big size of telephone cables or armoured Cu/Al cables..



技术数据 TECHNICAL DATA:

型号 Model No:	SC-85	SC-105
切削力 Cutting force:	60KN	120KN
切割范围 Cutting range:	Φ100mm _{max} (用于电话线for telephone cable) Φ75mm _{max} (用于铠装铜/铝电缆for armoured Cu/Al cable)	Φ100mm _{max} (用于电话线for telephone cable) Φ75mm _{max} (用于铠装铜/铝电缆for armoured Cu/Al cable)
行程 Stroke:	90mm	110mm
长度 Length:	approx.480mm	approx.505mm
重量 Weight:	approx.7.90kg	approx.8.40kg
包装 Package:	塑料盒 Plastic box	塑料盒 Plastic box
注：它可以与任何液压手动泵或电动泵一起使用 NOTE: it can use with any hydraulic hand pump or electrical pump		

CC-50B

产品特点

- 分体式液压电缆剪可与液压手动泵或电动液压泵配合使用，适用于大尺寸电话电缆或铠装Cu/Al电缆。

FEATURES:

- Split hydraulic cable cutter can work with hydraulic handpump or electric hydraulic pump, it is suit for big size of telephone cables or armoured Cu/Al cables..



型号 Model No:	CC-50B
切削力 Cutting force:	116KN
切割范围 Cutting range:	Φ50mm _{max} (用于电话线for telephone cable) Φ45mm _{max} (用于铠装铜/铝电缆for armoured Cu/Alu cable)
行程 Stroke:	24mm
长度 Length:	approx.340mm
重量 Weight:	approx.6.20kg
包装 Package:	塑料盒 Plastic box
注：它可以与任何液压手动泵或电动泵一起使用 NOTE: it can use with any hydraulic hand pump or electrical pump	

分体式线缆剪头部 SPLIT-TYPE CABLE CUTTER HEAD

SC-40

产品特点

- 分体式液压电缆剪可与液压手动泵或电动液压泵配合使用，适用于大尺寸ACSR电缆或多股钢丝。

FEATURES:

- Split hydraulic cable cutter can work with hydraulic handpump or electric hydraulic pump, it is suit for big size of telephone cables or steel wire multi-strands.

型号 Model No:	SC-40
切削力 Cutting force:	60KN
切割范围 Cutting range:	Φ40mm ^{max} 铜/铝/铠装电缆/钢芯铝绞线 Armoured and Cu/Al cable/ACSR stranded wire
行程 Stroke:	42mm
长度 Length:	approx.320mm
重量 Weight:	approx.3.80kg
包装 Package:	塑料盒 Plastic box
注：它可以与任何液压手动泵或电动泵一起使用 NOTE: it can use with any hydraulic hand pump or electrical pump	

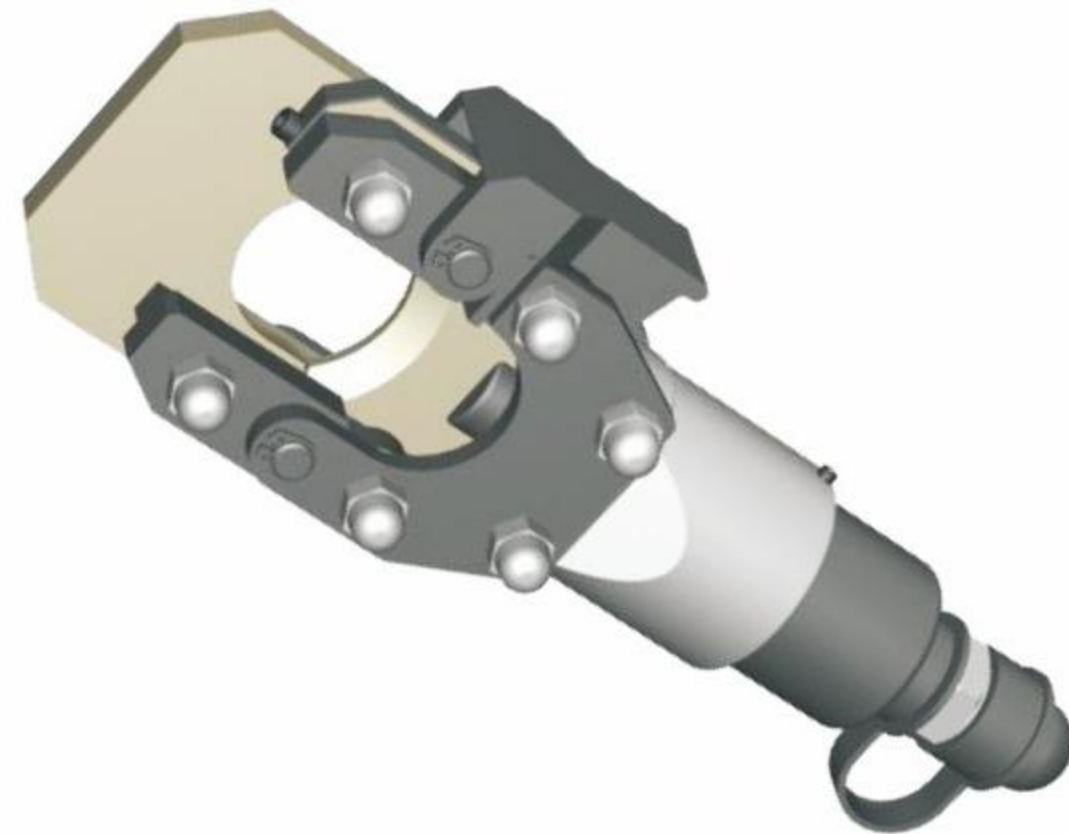

SC-55

产品特点

- 翻转式顶部切割头可旋转360°
- 新的两级液压装置减少了切割周期，切割完成后自动释放压力
- 必要时手动释放

FEATURES:

- Flip top cutting head rotates 360°.
- New two stage hydraulic to reduce cutting cycle, automatic release pressure when cut is complete.
- Manual release in case of need.

技术数据 TECHNICAL DATA:

型号 Model No:	SC-55
切削力 Cutting force:	120KN
切割范围 Cutting range:	Φ50mm ^{max} 铜/铝/铠装电缆/钢芯铝绞线 Armoured and Cu/Al cable/ACSR stranded wire
行程 Stroke:	50mm
长度 Length:	approx.355mm
重量 Weight:	approx.4.20kg
包装 Package:	塑料盒 Plastic box
注：它可以与任何液压手动泵或电动泵一起使用 NOTE: it can use with any hydraulic hand pump or electrical pump	



(15吨) SC-85C / 105C / 120C

型号	(15吨)SC-85C	(15吨)SC-105C	(15吨)SC-120C
剪切力	120KN	150KN	150KN
行程	70mm	105mm	120mm
剪切次数 (饱和电压)	40-70次	40-70次	40-70次
剪切范围	Φ70mm _{max} (铠装和铜/铝电缆)	Φ105mm _{max} (铠装和铜/铝电缆)	Φ120mm _{max} (铠装和铜/铝电缆)
净重	4kg	4.5kg	5kg
包装	塑料盒	塑料盒	塑料盒

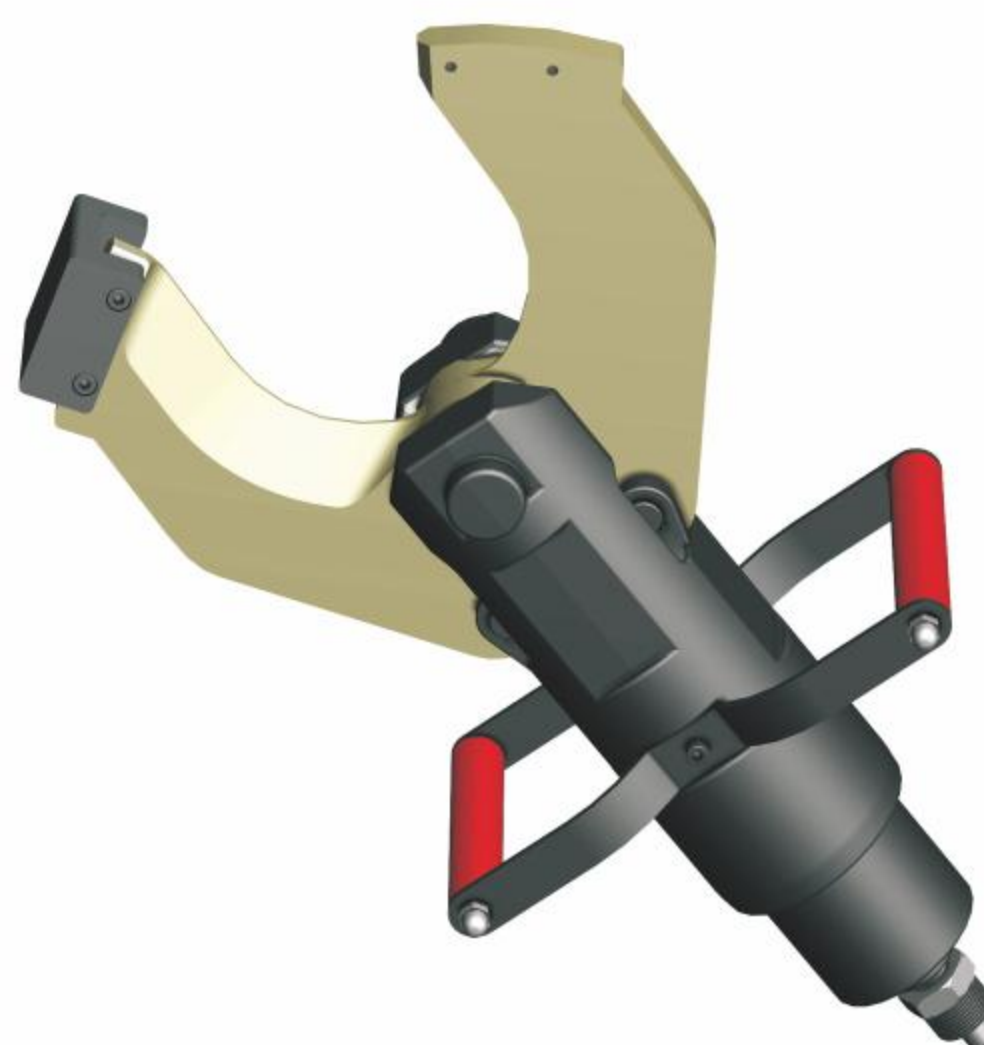

产品特点 FEATURES:

- 开口C型切割头
- 液压快速接头与泵连接以便工作
- 导板设计避免了切割过程中刀片移位

- Opening C type cutting head.
- Hydraulic quick coupler connect with the pump for working.
- Guide pad design avoid the blade dislocation during cutting procession.

(25吨) SC-105C / 120C / 135C

型号	(25吨)SC-105C	(25吨)SC-120C	(25吨)SC-135C
剪切力	200KN	200KN	200KN
行程	105mm	120mm	135mm
剪切次数 (饱和电压)	40-70次	40-70次	40-70次
剪切范围	Φ105mm _{max} (铠装和铜/铝电缆)	Φ120mm _{max} (铠装和铜/铝电缆)	Φ135mm _{max} (铠装和铜/铝电缆)
净重	5.5kg	6kg	7kg
包装	塑料盒	塑料盒	塑料盒



分体式铁管专用剪刀头部
SPLIT-TYPE SPECIAL FOR IRON PIPE CUTTER HEAD

铁管专用

(15吨) SC-105CTG / 120CTG

型号	(15吨)SC-105CTG	(15吨)SC-120CTG
剪切力	150KN	150KN
行程	62mm	62mm
剪切次数	70次 (饱和电压)	50次 (饱和电压)
剪切范围	δ3mm Φ60mm _{max}	δ3mm Φ80mm _{max}
净重	4.5kg	5kg
包装	塑料盒	塑料盒

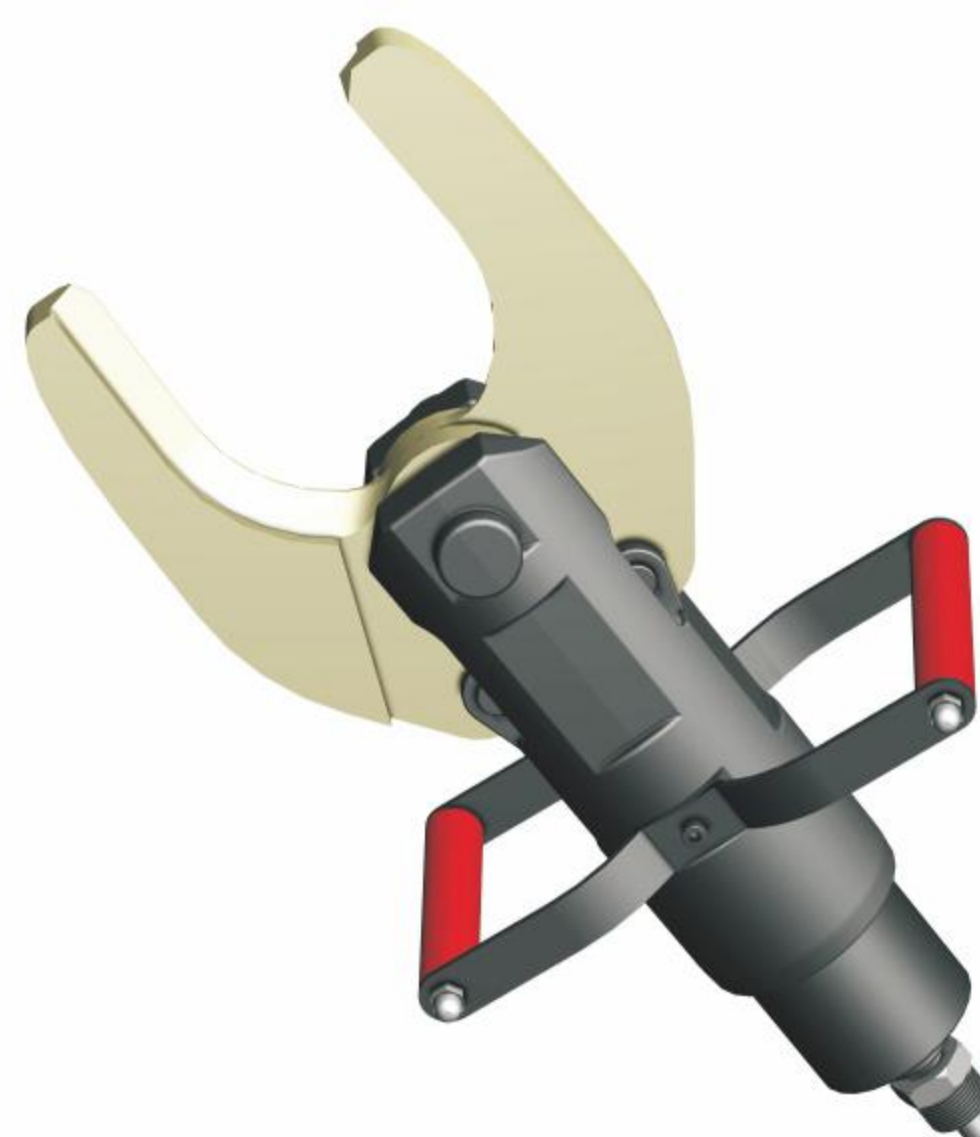

分体式剪刀头部

产品特点 FEATURES:

- 开口C型切割头
- 液压快速接头与泵连接以便工作
- 导板设计避免了切割过程中刀片移位
- Opening C type cutting head.
- Hydraulic quick coupler connect with the pump for working.
- Guide pad design avoid the blade dislocation during cutting procession.

(25吨) SC-105CTG / 120CTG / 135CTG

铁管专用

型号	(25吨)SC-105CTG	(25吨)SC-120CTG	(25吨)SC-135CTG
剪切力	200KN	200KN	200KN
行程	62mm	62mm	62mm
剪切次数	70次 (饱和电压)	50次 (饱和电压)	40次 (饱和电压)
剪切范围	δ4mm Φ60mm _{max}	δ4mm Φ80mm _{max}	δ4mm Φ100mm _{max}
净重	5.5kg	6kg	7kg
包装	塑料盒	塑料盒	塑料盒



SPLIT-TYPE CUTTER HEAD

EBS-60UNV (连续压接型)



EB-60UNV (常规型)



DES-60UNV (无刷连续压接型)



DE-60UNV (无刷常规型)



技术参数 / TECHNICAL DATA

压接力 Crimping force:	60KN		
行程 Stroke:	42mm		
剪切次数 Cutting times:	70times (饱和电压 Per saturation voltage)		
剪切范围 Cutting range:	Φ40mm _{max} (铜铝和铠装电缆 Armoured and Cu/Al cable)		
压接次数 Crimping times:	160times (饱和电压 Per saturation voltage)		
压接范围 Crimping range:	16-300mm ²		
冲孔次数 Punching times:	100times (饱和电压 Per saturation voltage)		
冲孔范围 Punching range:	Φ22.5-Φ61.5mm		
冲力 Round punch Max.:	61.5mm		
工作周期 Working cycle:	3-15s		
电池电压/容量 Voltage/capacity:	18V/4.0Ah		
净重 Net weight:	4.8kg		
充电时间 Charging time:	2 hours		
包装 Package:	塑料盒 Plastic box		
配件 ACCESSORIES			
压接模具 Crimping dies:	4,6,10,16,25,35,50,70,95,120,150,185,240,300mm ²		
冲孔模具 Punching dies:	22.5, 28.3, 34.6, 43.2, 49.6, 61.5mm		
压接适配器 Adapter for crimping:	1pc	垫片 Spacer:	1pc
冲孔适配器 Adapter for punching:	1pc	电池 Battery:	2pcs
拉钉 3/4", 16UN Draw stud:	1pc	充电器 Charger:	1pc
拉钉 7/16", 20UN Draw stud:	1pc		



充电式多功能液压工具（压接/切割/打孔） CHARGING TYPE MULTI-FUNCTIONAL HYDRAULIC TOOL

EMEADS[®]
ZHEJIANG EMEADS TOOLS CO.,LTD

GES-60UNV / GE-60UNV (迷你连续压接型)

技术参数 / TECHNICAL DATA	
压接力 Crimping force:	60KN
行程 Stroke:	42mm
剪切次数 Cutting times:	70times (饱和电压 Per saturation voltage)
剪切范围 Cutting range:	Φ40mm _{max} (铜/铝和铠装电缆 Armoured and Cu/Al cable)
压接次数 Crimping times:	160times (饱和电压 Per saturation voltage)
压接范围 Crimping range:	16-300mm ²
冲孔次数 Punching times:	100times (饱和电压 Per saturation voltage)
冲孔范围 Punching range:	Φ22.5-Φ61.5mm
冲力 Round punch Max.:	61.5mm
工作周期 Working cycle:	3-15s
电池电压/容量 Voltage/capacity:	18V/4.0Ah
净重 Net weight:	4.8kg
充电时间 Charging time:	2 hours
包装 Package:	塑料盒 Plastic box
配件 ACCESSORIES	
压接模具 Crimping dies:	4,6,10,16,25,35,50,70,95,120,150,185,240,300mm ²
冲孔模具 Punching dies:	22.5, 28.3, 34.6, 43.2, 49.6, 61.5mm
压接适配器 Adapter for crimping:	1pc
冲孔适配器 Adapter for punching:	1pc
拉钉 3/4", 16UN Draw stud:	1pc
拉钉 7/16", 20UN Draw stud:	1pc
垫片 Spacer:	1pc
电池 Battery:	2pcs
充电器 Charger:	1pc



多功能液压工具

手动式多功能液压工具（压接/切割/打孔） MANUAL TYPE MULTI-FUNCTIONAL HYDRAULIC TOOL

HT-60UNV (手动型)

技术参数 / TECHNICAL DATA	
压接力 Working force:	60KN
行程 Stroke:	42mm
压接范围 Crimping range:	Cu16-300mm ² Al10-240mm ²
剪切范围 Cutting range:	Φ40mm _{max} (铜/铝和铠装电缆 Armoured and Cu/Al cable)
冲孔范围 Punching range:	Φ22.5-61.5mm 3.5mm低碳钢 in the 3.5mm mild steel
长度 Length:	540mm
重量 Weight:	3.5kg
包装 Package:	钢制外壳 steel case
配件 ACCESSORIES	
压接模具 Crimping dies:	16,25,35,50,70,95,120,150,185,240,300mm ²
冲孔模具 Punching dies:	22.5, 28.3, 34.6, 43.2, 49.6, 61.5mm
压接适配器 Adapter for crimping:	1pc
冲孔适配器 Adapter for punching:	1pc
拉钉 3/4", 16UN Draw stud:	1pc
拉钉 3/8", 24UN Draw stud:	1pc
垫片 Spacer:	1pc



MULTI-FUNCTIONAL HYDRAULIC TOOLS

多功能 MULTI-FUNCTIONAL

单一工具压接、切割和冲孔

CRIMPING, CUTTING AND PUNCHING WITH ONE SINGLE TOOL

<p>适配器 (Adapter)</p> 	<p>用途: 压接 (Application: For crimping)</p> <p>铜压接端子16-300mm² Cu compression cable lugs and compression joints 16-300mm² 铝压接端子10-240mm² Al compression cable lugs and compression joints 10-240mm²</p>
<p>刀 (Blade)</p> 	<p>用途: 剪切 (Application: For cutting)</p> <p>Φ40mm 铜/铝电缆和铠装电缆 Φ40mm Cu/Al cable and Armored cable</p>
<p>适配器 (Adapter)</p> 	<p>用途: 冲孔 (Application: For punching)</p> <p>圆模22.5-61.5mm冲3.5mm软钢板 22.5-61.5mm Round dies. for 3.5 mm mild steel punching</p>





产品特点 / FEATURES

- 

液压单元具有自动回缩功能，当达到最大工作压力时，该功能可将活塞返回到其起始位置。
The hydraulic unit incorporates an automatic retraction which returns the piston into its starting position when the maximum operating pressure is reached.
- 

手动回缩允许用户在不正确的压接情况下将活塞返回到起始位置。当松开触发按钮时，当活塞和压模停止向前运动时，该装置将配备一个特殊的制动器装置。
A manual retraction allows the user to return the piston into the starting position in case of an incorrect crimp. The unit is equipped with a special brake when stops the forward motion of the piston & die when the trigger is released.
- 

该单元配备有双活塞泵，通过快速接近模具使连接器向前并缓慢的工作运动而受到损害。
The unit is equipped with a double piston pump which is characterised by a rapid approach of the dies forwards the connector and a slow working motion.
- 

头部可以绕纵轴平滑旋转350°，以便更好地进入狭窄的角落和其他困难的工作区域。
The head can be smoothly turned by 350° around the longitudinal axis in order to gain better access to tight corners and other difficult working areas.
- 

锂离子电池既没有记忆效应，也不会自然放电。即使长时间不操作后，工具也始终准备就绪。此外，与镍氢电池相比，我们发现功率比更低，容量增加了50%，充电周期更短。
Li-ion batteries do neither have a memory effect nor self discharge. Even after long periods of non operation the tool is always ready to operate. In addition we see a lower power weight ratio with 50% more capacity and shorter charging cycles compare to NiMH batteries.
- 

温度传感器在长时间工作时，如果温度超过60°C，工具会自动停止工作，并发出故障信号，这意味着工具必须等到温度降低到正常水平才能继续工作。
A Temperature sensor makes the tool stop working automatically when the temperature over 60°C under long time working, the fault signal sounds, it means the tool can't continue work until the temperature reduced to the normal.

多功能选配钳头 MULTIFUNCTIONAL OPTIONAL CLAMP HEAD



EF-400 压接钳

技术参数/ TECHNICAL DATA	
压接力 Crimping force:	120KN
行程 Stroke:	42mm
压接次数 Crimping times:	120times (Cu150mm ²) (饱和电压 Per saturation voltage)
压接周期 Crimping cycle:	6-18s 取决于电缆的尺寸 Depend on the size of cable
净重 Net weight:	3.0kg



EF-400U 压接钳

技术参数/ TECHNICAL DATA	
压接力 Crimping force:	120KN
行程 Stroke:	20mm
压接次数 Crimping times:	120times (Cu150mm ²) (饱和电压 Per saturation voltage)
压接周期 Crimping cycle:	6-18s 取决于电缆的尺寸 Depend on the size of cable
净重 Net weight:	1.5kg



EF-40 线缆剪

技术参数/ TECHNICAL DATA	
切割力 Cutting force:	60KN/120KN (120KN可选配钳头)
行程 Stroke:	40mm
剪切次数 Cutting times:	130times (饱和电压 Per saturation voltage)
剪切范围 Cutting range:	Φ35mm max 钢芯铝绞线 ACSR stranded wire
净重 Net weight:	2kg



EF-50 线缆剪

技术参数/ TECHNICAL DATA	
切割力 Cutting force:	120KN
行程 Stroke:	50mm
剪切次数 Cutting times:	70times (饱和电压 Per saturation voltage)
剪切范围 Cutting range:	Φ40mm max 铜/铝和铠装电缆 Armoured and Cu/Al cable
净重 Net weight:	2.5kg



EF-85C 线缆剪

技术参数/ TECHNICAL DATA	
切割力 Cutting force:	120KN
行程 Stroke:	85mm
剪切次数 Cutting times:	130times (饱和电压 Per saturation voltage)
剪切范围 Cutting range:	Φ70mm max 铜/铝和铠装电缆 Armoured and Cu/Al cable
净重 Net weight:	6.0kg



EF-120C 线缆剪

技术参数/ TECHNICAL DATA	
切割力 Cutting force:	200KN
行程 Stroke:	85mm
剪切次数 Cutting times:	130times (饱和电压 Per saturation voltage)
剪切范围 Cutting range:	Φ110mm max 铜/铝和铠装电缆 Armoured and Cu/Al cable
净重 Net weight:	6.0kg



EF-1220H 冲孔器

技术参数/ TECHNICAL DATA	
最大输出 Max.output:	120KN
行程 Stroke:	18mm
冲孔次数 Punching time:	250times (饱和电压 Per saturation voltage)
净重 Net weight:	5.0kg
冲孔范围 Cutting range:	Φ10.5, 13.5, 17.5, 20.5mm



EF-2436 螺母破切器

技术参数/ TECHNICAL DATA	
最大输出 Max.output:	120KN
行程 Stroke:	18mm
破切次数(饱和电压) Cutting times: (per saturation voltage)	250times 取决于M12-4.8级螺母 Depend on M12-4.8 grade nut
破切范围 Cutting range:	13-24mm
净重 Net weight:	1.5kg
螺母螺纹范围 Thread of nut range:	M8-M24

PIPE FITTING CLAMPING SERIES

管件卡压系列



EMEADS[®]
ZHEJIANG EMEADS TOOLS CO., LTD



便携轻巧 高效作业

LIGHT & EFFICIENT

性能稳定可靠 性价比高
Stable performance, high cost performance



一键启动

One touch start



镀镍防锈压模

Nickel plated anti rust die



应用广泛

Widely used



安全保障

Security

产品特点 / PRODUCT FEATURES

- 整个压接过程最快仅需要短短的3秒钟，在每次完成卡压后，活塞自动回缩，无需手动切换。
- 压接钳插销设计有弹簧装置，有效防止未锁紧的误操作。
- 衡力技术确保稳定的压接力。
- 橡胶手柄，整体重量分布平衡，长时间使用中无疲劳感。
- 电机驱动，搭载微型计算机控制系统和微型双级液压系统。
- The whole crimping process only takes a short time of 3 seconds at the fastest time. After each compression, the piston automatically retracts without manual switching.
- The latch of crimping pliers is designed with spring device to effectively prevent misoperation without locking.
- The balance force technology ensures stable pressure relay force.
- Rubber handle, the overall weight distribution is balanced, and there is no fatigue during long use.
- Motor driven, equipped with microcomputer control system and micro two-stage hydraulic system.

GES-1525

EMEADS[®]
ZHEJIANG EMEADS TOOLS CO., LTD

充电式液压卡压工具

CHARGING TYPE HYDRAULIC CLAMPING TOOL

一键启动 操作简便

ONE BUTTON START, EASY TO OPERATE

适用于卡压不锈钢水管，消防碳钢管道、
燃气碳钢管道、多层复合管

The tool is applicable to stainless steel pipe, fire carbon steel pipe,
gas carbon steel pipe and multi-layer composite pipe



铜管
Copper tube



多层复合管
Multilayer
composite tube



PEX管
PEX pipe



不锈钢管
Stainless steel pipe



碳钢管
Carbon steel pipe



电池 Battery



充电器 Charger



压模 Mold



技术参数 / TECHNICAL DATA:

卡压范围 Compression range:	12-28mm(1/2"-1") 薄壁不锈钢管 12-35mm(1/2"-1") 薄壁紫铜管 12-32mm 塑料管、铝塑复合管 12-28mm (1/2"-1") thin-wall stainless steel pipe 12-35mm (1/2"-1") thin-wall copper tube 12-32mm Plastic pipe, aluminum plastic composite pipe
----------------------------	--

注意：不同管件类型及材质，卡压范围会有所变化，具体应根据配套管件而定
Note: different pipe type and material, compression range will change, should be based on the specific supporting pipe

额定出力 Rated output: 19KN

行程 Trip: 30mm

单次卡压耗时
Time consumption of single clamping: 2-4s

标配电池 Standard battery: 18V / 4.0Ah 锂电池
18V / 4.0Ah lithium battery

标配充电器 Standard charger: AC 100V~240V 50~60Hz

电池充电时间 Battery charging time: 约2小时 (About 2 hours)

保养周期 Maintenance cycle: 30000次(times)

每饱和电池卡压次数
Number of stuck voltage per saturated battery: 180次 (DN20不锈钢管接头)
180 times (DN20 stainless steel pipe joint)

重量 Weight: 约2.0kg (工具带电池)
约3.5kg (工具带电池和一副卡钳)
About 2.0kg (tool with battery)
About 3.5kg (tool with battery and a pair of calipers)

工具尺寸 Tool dimensions: 363x120x75mm

配件 / ACCESSORIES:

电池 Battery:	2 pieces	充电器 Charger:	1 piece	模具配置 Mold configuration:	15, 20, 25mm
-------------	----------	--------------	---------	--------------------------	--------------

便携轻巧 高效作业

LIGHT & EFFICIENT

性能稳定可靠 性价比高

Stable performance, high cost performance



一键启动

One touch start



镀镍防锈压模

Nickel plated anti rust die



应用广泛

Widely used



安全保障

Security

产品特点 / PRODUCT FEATURES

- 整个压接过程最快仅需要短短的10秒钟，在每次完成卡压后，活塞自动回缩，无需手动切换。
- 压接钳插销设计有弹簧装置，有效防止未锁紧的误操作。
- 衡力技术确保稳定的压接力。
- 橡胶手柄，整体重量分布平衡，长时间使用中无疲劳感。
- 电机驱动，搭载微型计算机控制系统和微型双级液压系统。
- The whole crimping process only takes a short time of 10 seconds at the fastest time. After each compression, the piston automatically retracts without manual switching.
- The latch of crimping pliers is designed with spring device to effectively prevent misoperation without locking.
- The balance force technology ensures stable pressure relay force.
- Rubber handle, the overall weight distribution is balanced, and there is no fatigue during long use.
- Motor driven, equipped with microcomputer control system and micro two-stage hydraulic system.

GE-1550

EMEADS[®]
ZHEJIANG EMEADS TOOLS CO., LTD

充电式液压卡压工具

CHARGING TYPE HYDRAULIC CLAMPING TOOL

一键启动 操作简便

ONE BUTTON START, EASY TO OPERATE

适用于卡压不锈钢水管、铜管、
多层复合管

The tool is applicable to clamping stainless steel water pipe, copper pipe and multi-layer composite pipe



铜管
Copper tube



多层复合管
Multilayer
composite tube



PEX管
PEX pipe



不锈钢管
Stainless steel pipe



电池 Battery



充电器 Charger



压模 Mold

技术参数 / TECHNICAL DATA:

卡压范围 Compression range:	12-54mm(1/2"-2") 薄壁不锈钢管、塑料管、铝塑复合管、铜管 12-54mm (1/2"-2") Thin-wall stainless steel pipe, Plastic pipe, aluminum plastic composite pipe, copper pipe	标配电池 Standard battery:	18V / 4.0Ah 锂电池 18V / 4.0Ah lithium battery
注意: 不同管件类型及材质, 卡压范围会有所变化, 具体应根据配套管件而定 Note: different pipe type and material, compression range will change, should be based on the specific supporting pipe		标配充电器 Standard charger:	AC 100V~240V 50~60Hz
额定出力 Rated output:	32KN (活塞出力 Piston output)	电池充电时间 Battery charging time:	约2小时 (About 2 hours)
行程 Trip:	40mm	保养周期 Maintenance cycle:	30000次(times)
单次卡压耗时 Time consumption of single clamping:	3-4.5s (根据管件的直径) 3-4.5s (According to the diameter of the pipe fitting)	每饱和电池卡压次数 Number of stuck voltage per saturated battery:	约350次 (DN20) About 350 times(DN20)
重量 Weight:		工具尺寸 Tool dimensions:	3.9kg (工具带电池) 6.1kg (工具带电池和一副卡钳) 3.9kg (tool with battery) 6.1kg (tool with battery and a pair of calipers)
模具配置 Mold configuration:			15, 20, 25, 32, 40, 50mm 不锈钢水管(默认)、燃气管选配、消防管选配

配件 / ACCESSORIES:

电池 Battery:	2 pieces	充电器 Charger:	1 piece	模具配置 Mold configuration:	15, 20, 25, 32, 40, 50mm 不锈钢水管(默认)、燃气管选配、消防管选配
-------------	----------	--------------	---------	--------------------------	---



便携轻巧 高效作业

LIGHT & EFFICIENT

性能稳定可靠 性价比高

Stable performance, high cost performance



一键启动

One touch start



镀镍防锈压模

Nickel plated anti rust die



应用广泛

Widely used



安全保障

Security

产品特点 / PRODUCT FEATURES

- 整个压接过程最快仅需要短短的10秒钟，在每次完成卡压后，活塞自动回缩，无需手动切换。
- 压接钳插销设计有弹簧装置，有效防止未锁紧的误操作。
- 衡力技术确保稳定的压接力。
- 橡胶手柄，整体重量分布平衡，长时间使用中无疲劳感。
- 电机驱动，搭载微型计算机控制系统和微型双级液压系统。
- The whole crimping process only takes a short time of 10 seconds at the fastest time. After each compression, the piston automatically retracts without manual switching.
- The latch of crimping pliers is designed with spring device to effectively prevent misoperation without locking.
- The balance force technology ensures stable pressure relay force.
- Rubber handle, the overall weight distribution is balanced, and there is no fatigue during long use.
- Motor driven, equipped with microcomputer control system and micro two-stage hydraulic system.

GE-1550R

EMEADS[®]
ZHEJIANG EMEADS TOOLS CO., LTD

充电式液压卡压工具

CHARGING TYPE HYDRAULIC CLAMPING TOOL

一键启动 操作简便

ONE BUTTON START, EASY TO OPERATE

适用于卡压不锈钢水管、铜管、 多层复合管

The tool is applicable to clamping stainless steel water pipe, copper pipe and multi-layer composite pipe



不锈钢环压接头
Stainless steel ring
compression joint



不锈钢管
Stainless steel pipe



多层复合管
Multilayer
composite tube



铜管
Copper tube



电池 Battery



充电器 Charger



压模 Mold

技术参数 / TECHNICAL DATA:

卡压范围 Compression range:	12-54mm(1/2"-2") 薄壁不锈钢管、塑料管、铝塑复合管、铜管 12-54mm (1/2"-2") Thin-wall stainless steel pipe, Plastic pipe, aluminum plastic composite pipe, copper pipe	标配电池 Standard battery:	18V / 4.0Ah 锂电池 18V / 4.0Ah lithium battery
注意: 不同管件类型及材质, 卡压范围会有所变化, 具体应根据配套管件而定 Note: different pipe type and material, compression range will change, should be based on the specific supporting pipe		标配充电器 Standard charger:	AC 100V~240V 50~60Hz
额定出力 Rated output:	32KN (活塞出力 Piston output)	电池充电时间 Battery charging time:	约2小时 (About 2 hours)
行程 Trip:	40mm	保养周期 Maintenance cycle:	30000次(times)
单次卡压耗时 Time consumption of single clamping:	3-4.5s (根据管件的直径) 3-4.5s (According to the diameter of the pipe fitting)	每饱和电池卡压次数 Number of stuck voltage per saturated battery:	约350次 (DN20) About 350 times(DN20)
		重量 Weight:	3.9kg (工具带电池) 6.1kg (工具带电池和一副卡钳) 3.9kg (tool with battery) 6.1kg (tool with battery and a pair of calipers)
		工具尺寸 Tool dimensions:	450x81x128mm

配件 / ACCESSORIES:

电池 Battery:	2 pieces	充电器 Charger:	1 piece	模具配置 Mold configuration:	15, 20, 25, 32, 40, 50mm 不锈钢水管(默认)、燃气管选配、消防管选配
-------------	----------	--------------	---------	--------------------------	---

便携轻巧 高效作业

LIGHT & EFFICIENT

将碳钢管表面涂层损伤降到最低！
Minimize coating damage on carbon steel pipes!



一键启动

One touch start



镀镍防锈压模

Nickel plated anti rust die



应用广泛

Widely used



安全保障

Security

产品特点 / PRODUCT FEATURES

- 整个压接过程最快仅需要短短的10秒钟，在每次完成卡压后，活塞自动回缩，无需手动切换。
- 压接钳插销设计有弹簧装置，有效防止未锁紧的误操作。
- 衡力技术确保稳定的压接力。
- 橡胶手柄，整体重量分布平衡，长时间使用中无疲劳感。
- 电机驱动，搭载微型计算机控制系统和微型双级液压系统。
- The whole crimping process only takes a short time of 10 seconds at the fastest time. After each compression, the piston automatically retracts without manual switching.
- The latch of crimping pliers is designed with spring device to effectively prevent misoperation without locking.
- The balance force technology ensures stable pressure relay force.
- Rubber handle, the overall weight distribution is balanced, and there is no fatigue during long use.
- Motor driven, equipped with microcomputer control system and micro two-stage hydraulic system.

GE-1550Q

EMEADS[®]
ZHEJIANG EMEADS TOOLS CO.,LTD

充电式燃气、消防碳钢管道压接工具

CHARGING TYPE GAS, FIRE CARBON STEEL PIPE CRIMPING TOOLS

一键启动 操作简便

ONE BUTTON START, EASY TO OPERATE

专用于消防碳钢管道、燃气碳钢管道环压
最新技术方案。

It is specially used for the latest technical scheme of carbon steel pipeline for fire protection and carbon steel pipeline for gas.



铜管
Copper tube



燃气管道
Gas pipeline



消防管道
Fire fighting pipeline



电池 Battery



充电器 Charger



压模 Mold

技术参数 / TECHNICAL DATA:

卡压范围 Compression range:	12-54mm(1/2"-2") 碳钢管、薄壁不锈钢管、塑料管、铝塑复合管、铜管 12-54mm (1/2"-2") Carbon steel pipe, thin-wall stainless steel pipe, plastic pipe, aluminum plastic composite pipe, copper pipe	标配电池 Standard battery:	18V / 4.0Ah 锂电池 18V / 4.0Ah lithium battery
注意: 不同管件类型及材质, 卡压范围会有所变化, 具体应根据配套管件而定 Note: different pipe type and material, compression range will change, should be based on the specific supporting pipe		标配充电器 Standard charger:	AC 100V~240V 50~60Hz
额定出力 Rated output:	32KN (活塞出力 Piston output)	电池充电时间 Battery charging time:	约2小时 (About 2 hours)
行程 Trip:	40mm	保养周期 Maintenance cycle:	30000次(times)
单次卡压耗时 Time consumption of single clamping:	3-4.5s (根据管件的直径) 3-4.5s (According to the diameter of the pipe fitting)	每饱和电池卡压次数 Number of stuck voltage per saturated battery:	约350次 (DN20) About 350 times(DN20)
重量 Weight:		工具尺寸 Tool dimensions:	450x81x128mm
			3.9kg (工具带电池) 6.1kg (工具带电池和一副卡钳) 3.9kg (tool with battery) 6.1kg (tool with battery and a pair of calipers)

配件 / ACCESSORIES:

电池 Battery:	2 pieces	充电器 Charger:	1 piece	模具配置 Mold configuration:	15, 20, 25, 32, 40, 50mm
-------------	----------	--------------	---------	--------------------------	--------------------------

便携轻巧 高效作业

LIGHT & EFFICIENT

将碳钢管表面涂层损伤降到最低！

Minimize coating damage on carbon steel pipes!



一键启动

One touch start



镀镍防锈压模

Nickel plated anti rust die



应用广泛

Widely used



安全保障

Security



GE-15100

充电式液压卡压工具

CHARGING TYPE HYDRAULIC CLAMPING TOOL

适用卡压不锈钢水管，
消防碳钢管道、
燃气碳钢管道、
多层复合管

The tool is applicable to stainless steel pipe, fire carbon steel pipe, gas carbon steel pipe and multi-layer composite pipe



铜管
Copper tube



多层复合管
Multilayer composite tube



PEX管
PEX pipe



不锈钢管
Stainless steel pipe



碳钢管
Carbon steel pipe



电池 Battery



充电器 Charger

不锈钢管道压接套装

STAINLESS STEEL PIPE CRIMPING KIT

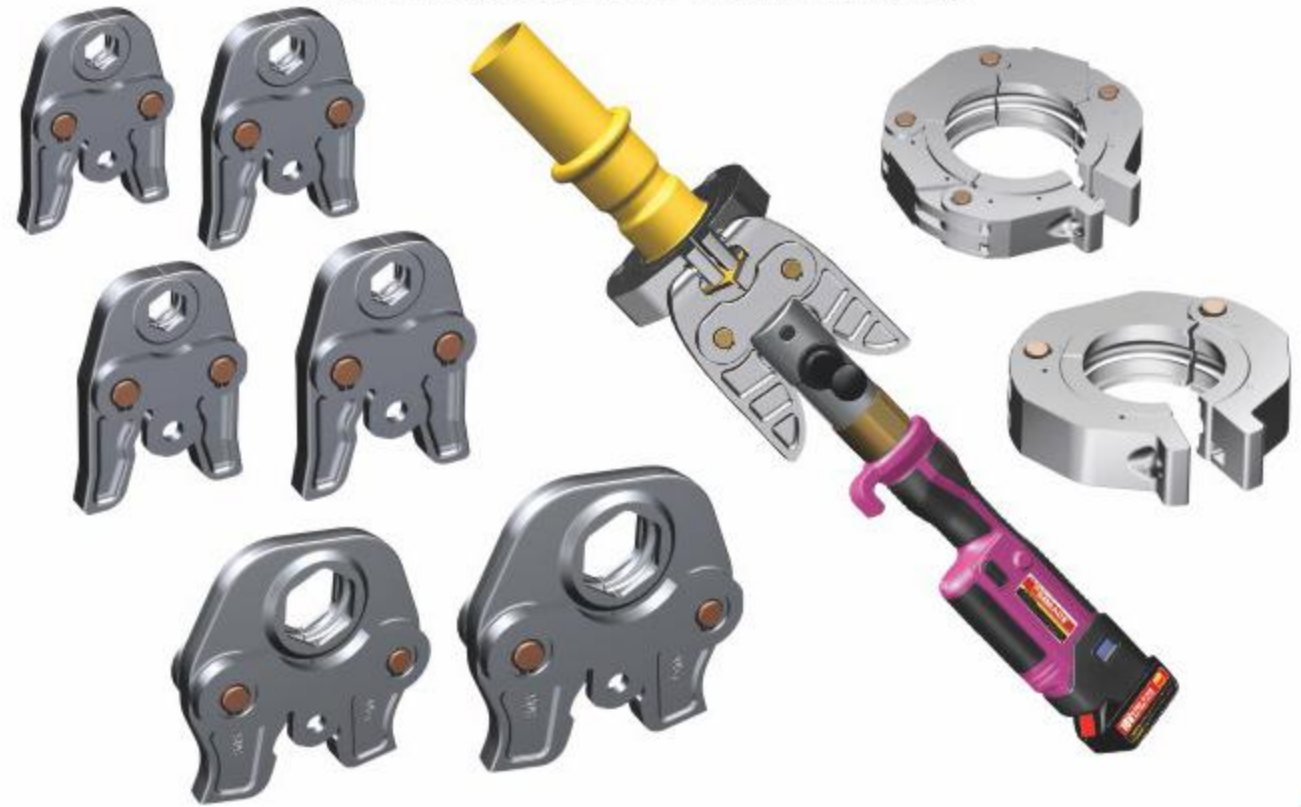

燃气/消防环压型套装

GAS/FIRE RING COMPRESSION TYPE SUIT

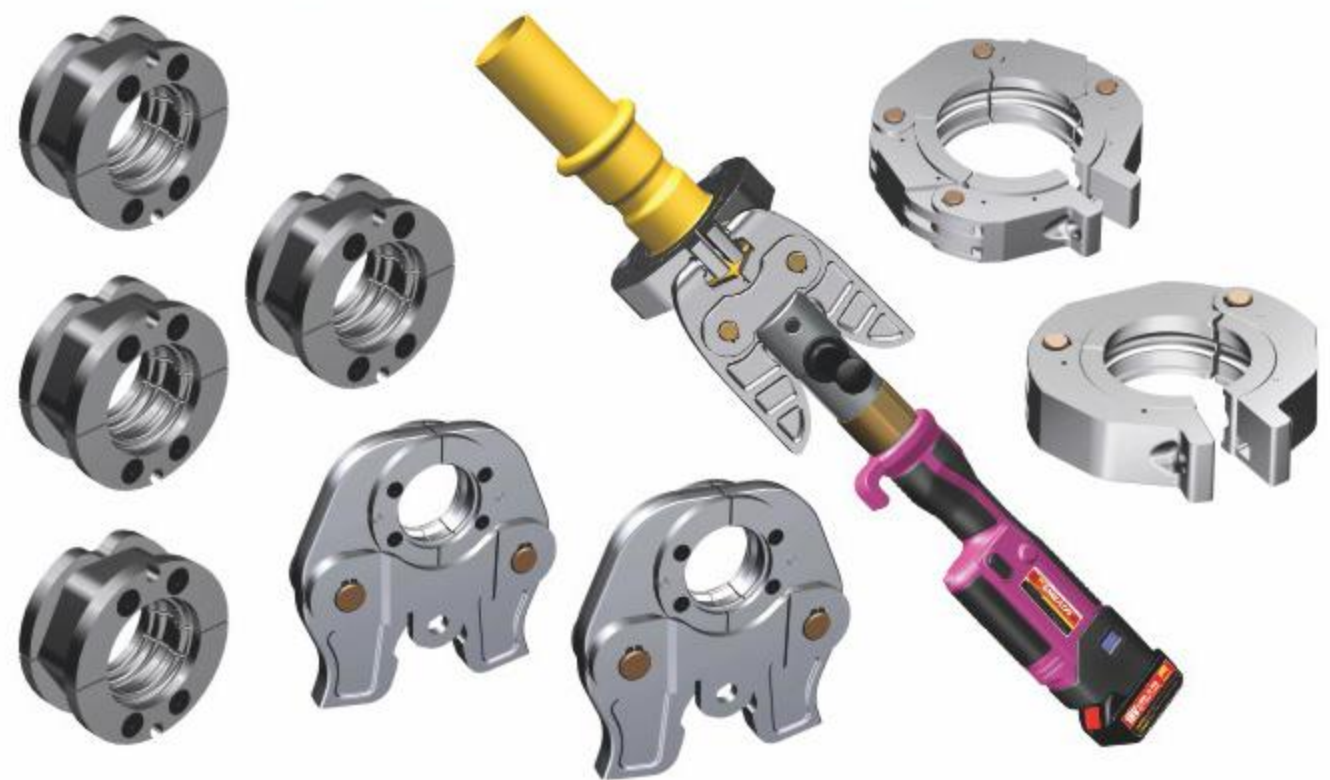

注: 15-100(可选配压模)

Note: 15-100 (optional pressure die)

技术参数 / TECHNICAL DATA:

卡压范围 Compression range:	12-54mm(1/2"-2") 12-108mm(1/2"-4")	{ 薄壁不锈钢管、消防/燃气碳钢管 } { 塑料管、铝塑复合管、铜管 }
	12-54mm(1/2"-2") 12-108mm(1/2"-4")	{ Thin-wall stainless steel pipe, fire/gas carbon steel pipe } { Plastic pipe, aluminum plastic composite pipe, copper pipe }
注意: 不同管件类型及材质, 卡压范围会有所变化, 具体应根据配套管件而定 Note: different pipe type and material, compression range will change, should be based on the specific supporting pipe		
额定出力 Rated output:	40KN (活塞出力 Piston output)	
行程 Trip:	95mm	
储油量 Oil storage:	250ml	
单次卡压耗时 Time consumption of single clamping:	3-8s (根据管件的直径) 3-8s (According to the diameter of the pipe fitting)	

标配电池 Standard battery:	18V / 4.0Ah 锂电池 18V / 4.0Ah lithium battery
标配充电器 Standard charger:	AC 100V~240V 50~60Hz
电池充电时间 Battery charging time:	约2小时 (About 2 hours)
保养周期 Maintenance cycle:	30000次(times)
每饱和电池卡压次数 Number of stuck voltage per saturated battery:	约360次 (DN20不锈钢管接头) About 360 times(DN20Stainless steel pipe joint)
毛重 Gross weight:	4.3kg
工具尺寸 Tool dimensions:	525x318x86mm

配件 / ACCESSORIES:

电池 Battery:	2 pieces	充电器 Charger:	1 piece	模具配置 Mold configuration:	15, 20, 25, 32, 40, 50, 65, 80, 100mm 不锈钢水管(默认)、燃气管选配、消防管选配
-------------	----------	--------------	---------	--------------------------	--

进口电机 动力强劲

POWERFUL IMPORTED MOTOR

性能稳定可靠 性价比高

Stable performance, high cost performance



安全保障
Security



镀镍防锈压模
Nickel plated anti rust die



应用广泛
Widely used



产品特点 / PRODUCT FEATURES

- 整个压接过程最快仅需要短短的3秒钟，在每次完成卡压后，活塞自动回缩，无需手动切换。
- 压接钳插销设计有弹簧装置，有效防止未锁紧的误操作。
- 衡力技术确保稳定的压接力。
- 橡胶手柄，整体重量分布平衡，长时间使用中无疲劳感。
- 电机驱动，搭载微型计算机控制系统和微型双级液压系统。
- The whole crimping process only takes a short time of 3 seconds at the fastest time. After each compression, the piston automatically retracts without manual switching.
- The latch of crimping pliers is designed with spring device to effectively prevent misoperation without locking.
- The balance force technology ensures stable pressure relay force.
- Rubber handle, the overall weight distribution is balanced, and there is no fatigue during long use.
- Motor driven, equipped with microcomputer control system and micro two-stage hydraulic system.

EB-1525

EMEADS[®]
ZHEJIANG EMEADS TOOLS CO., LTD

充电式液压卡压工具

CHARGING TYPE HYDRAULIC CLAMPING TOOL

另有型号可选：DE、DES无刷驱动
Other models: DE, DES brushless drive

适用于卡压不锈钢水管，消防碳钢管道、
燃气碳钢管道、多层复合管

The tool is applicable to stainless steel pipe, fire carbon steel pipe, gas carbon steel pipe and multi-layer composite pipe



铜管
Copper tube



多层复合管
Multilayer
composite tube



PEX管
PEX pipe



不锈钢管
Stainless steel pipe



碳钢管
Carbon steel pipe



电池 Battery



充电器 Charger



压模 Mold

技术参数 / TECHNICAL DATA:

卡压范围 Compression range:	12-28mm(1/2"-1") 薄壁不锈钢管 12-35mm(1/2"-1") 薄壁紫铜管 12-32mm 塑料管、铝塑复合管 12-28mm (1/2"-1") thin-wall stainless steel pipe 12-35mm (1/2"-1") thin-wall copper tube 12-32mm Plastic pipe, aluminum plastic composite pipe	标配电池 Standard battery:	18V / 4.0Ah 锂电池 18V / 4.0Ah lithium battery
注意：不同管件类型及材质，卡压范围会有所变化，具体应根据配套管件而定 Note: different pipe type and material, compression range will change, should be based on the specific supporting pipe		标配充电器 Standard charger:	AC 100V~240V 50~60Hz
额定出力 Rated output:	19KN (活塞出力 Piston output)	电池充电时间 Battery charging time:	约2小时 (About 2 hours)
行程 Trip:	30mm	保养周期 Maintenance cycle:	30000次(times)
单次卡压耗时 Time consumption of single clamping:	2.5-4s (根据管件的直径) 2.5-4s (According to the diameter of the pipe fitting)	每饱和电池卡压次数 Number of stuck voltage per saturated battery:	180次(times)
		重量 Weight:	2.4kg (工具带电池) 3.9kg (工具带电池和一副卡钳) 2.4kg (tool with battery) 3.9kg (tool with battery and a pair of calipers)
		工具尺寸 Tool dimensions:	300x286x75mm

配件 / ACCESSORIES:

电池 Battery:	2 pieces	充电器 Charger:	1 piece	模具配置 Mold configuration:	15, 20, 25mm
-------------	----------	--------------	---------	--------------------------	--------------



进口电机 动力强劲

POWERFUL IMPORTED MOTOR

性能稳定可靠 性价比高

Stable performance, high cost performance



安全保障
Security



镀镍防锈压模
Nickel plated anti rust die



应用广泛
Widely used

产品特点 / PRODUCT FEATURES

- 整个压接过程最快仅需要短短的10秒钟，在每次完成卡压后，活塞自动回缩，无需手动切换。
- 压接钳插销设计有弹簧装置，有效防止未锁紧的误操作。
- 衡力技术确保稳定的压接力。
- 橡胶手柄，整体重量分布平衡，长时间使用中无疲劳感。
- 电机驱动，搭载微型计算机控制系统和微型双级液压系统。
- The whole crimping process only takes a short time of 10 seconds at the fastest time. After each compression, the piston automatically retracts without manual switching.
- The latch of crimping pliers is designed with spring device to effectively prevent misoperation without locking.
- The balance force technology ensures stable pressure relay force.
- Rubber handle, the overall weight distribution is balanced, and there is no fatigue during long use.
- Motor driven, equipped with microcomputer control system and micro two-stage hydraulic system.

EB-1550

EMEADS[®]
ZHEJIANG EMEADS TOOLS CO.,LTD

充电式液压卡压工具

CHARGING TYPE HYDRAULIC CLAMPING TOOL

另有型号可选: DE、DES无刷驱动
Other models: DE, DES brushless drive

随时随地 无线束缚

WIRELESS BONDAGE, ANYTIME, ANYWHERE

适用于卡压不锈钢水管、铜管、多层复合管

The tool is applicable to clamping stainless steel water pipe, copper pipe and multi-layer composite pipe



铜管
Copper tube



多层复合管
Multilayer composite tube



PEX管
PEX pipe



不锈钢管
Stainless steel pipe



电池 Battery



充电器 Charger



压模 Mold

技术参数 / TECHNICAL DATA:

卡压范围 Compression range:	12-54mm(1/2"-2") 薄壁不锈钢管、塑料管、铝塑复合管、铜管 12-54mm (1/2"-2") Thin-wall stainless steel pipe, Plastic pipe, aluminum plastic composite pipe, copper pipe	标配电池 Standard battery:	18V / 4.0Ah 锂电池 18V / 4.0Ah lithium battery
注意: 不同管件类型及材质, 卡压范围会有所变化, 具体应根据配套管件而定 Note: different pipe type and material, compression range will change, should be based on the specific supporting pipe		标配充电器 Standard charger:	AC 100V~240V 50~60Hz
额定出力 Rated output:	32KN (活塞出力 Piston output)	电池充电时间 Battery charging time:	约2小时 (About 2 hours)
行程 Trip:	40mm	保养周期 Maintenance cycle:	30000次(times)
储油量 Oil storage:	115ml	每饱和电池卡压次数 Number of stuck voltage per saturated battery:	约350次 (DN20) About 350 times(DN20)
单次卡压耗时 Time consumption of single clamping:	3-4.5s (根据管件的直径) 3-4.5s (According to the diameter of the pipe fitting)	重量 Weight:	3.8kg (工具带电池) 6.0kg (工具带电池和一副卡钳) 3.8kg (tool with battery) 6.0kg (tool with battery and a pair of calipers)
		工具尺寸 Tool dimensions:	388x322x84mm

配件 / ACCESSORIES:

电池 Battery:	2 pieces	充电器 Charger:	1 piece	模具配置 Mold configuration:	15, 20, 25, 32, 40, 50mm
-------------	----------	--------------	---------	--------------------------	--------------------------



进口电机 动力强劲

POWERFUL IMPORTED MOTOR

性能稳定可靠 性价比高

Stable performance, high cost performance



安全保障
Security



镀铬防锈压模
Nickel plated anti rust die



应用广泛
Widely used

产品特点 / PRODUCT FEATURES

- 整个压接过程最快仅需要短短的10秒钟，在每次完成卡压后，活塞自动回缩，无需手动切换。
- 压接钳插销设计有弹簧装置，有效防止未锁紧的误操作。
- 衡力技术确保稳定的压接力。
- 橡胶手柄，整体重量分布平衡，长时间使用中无疲劳感。
- 电机驱动，搭载微型计算机控制系统和微型双级液压系统。
- The whole crimping process only takes a short time of 10 seconds at the fastest time. After each compression, the piston automatically retracts without manual switching.
- The latch of crimping pliers is designed with spring device to effectively prevent misoperation without locking.
- The balance force technology ensures stable pressure relay force.
- Rubber handle, the overall weight distribution is balanced, and there is no fatigue during long use.
- Motor driven, equipped with microcomputer control system and micro two-stage hydraulic system.

EB-1550R

EMEADS[®]
ZHEJIANG EMEADS TOOLS CO.,LTD

充电式液压卡压工具

CHARGING TYPE HYDRAULIC CLAMPING TOOL

随时随地 无线束缚

WIRELESS BONDAGE, ANYTIME, ANYWHERE

适用于卡压不锈钢水管、铜管、 多层复合管

The tool is applicable to clamping stainless steel water pipe, copper pipe and multi-layer composite pipe



不锈钢环压接头
Stainless steel ring
compression joint



不锈钢管
Stainless steel pipe



多层复合管
Multilayer
composite tube



铜管
Copper tube



电池 Battery



充电器 Charger



压模 Mold

技术参数 / TECHNICAL DATA:

卡压范围 Compression range:	12-54mm(1/2"-2") 薄壁不锈钢管、塑料管、铝塑复合管、铜管 12-54mm (1/2"-2") Thin-wall stainless steel pipe, Plastic pipe, aluminum plastic composite pipe, copper pipe	标配电池 Standard battery:	18V / 4.0Ah 锂电池 18V / 4.0Ah lithium battery
注意: 不同管件类型及材质, 卡压范围会有所变化, 具体应根据配套管件而定 Note: different pipe type and material, compression range will change, should be based on the specific supporting pipe		标配充电器 Standard charger:	AC 100V~240V 50~60Hz
额定出力 Rated output:	32KN (活塞出力 Piston output)	电池充电时间 Battery charging time:	约2小时 (About 2 hours)
行程 Trip:	40mm	保养周期 Maintenance cycle:	30000次(times)
单次卡压耗时 Time consumption of single clamping:	3-4.5s (根据管件的直径) 3-4.5s (According to the diameter of the pipe fitting)	每饱和电池卡压次数 Number of stuck voltage per saturated battery:	约350次 (DN20) About 350 times (DN20)
配件 / ACCESSORIES:		重量 Weight:	3.9kg (工具带电池) 6.1kg (工具带电池和一副卡钳) 3.9kg (tool with battery) 6.1kg (tool with battery and a pair of calipers)
电池 Battery:	2 pieces	工具尺寸 Tool dimensions:	450x81x128mm
充电器 Charger:	1 piece	模具配置 Mold configuration:	15, 20, 25, 32, 40, 50mm

进口电机 动力强劲

POWERFUL IMPORTED MOTOR

将碳钢管表面涂层损伤降到最低!

Minimize coating damage on carbon steel pipes!



安全保障
Security



镀镍防锈压模
Nickel plated anti rust die



应用广泛
Widely used

产品特点 / PRODUCT FEATURES

- 整个压接过程最快仅需要短短的10秒钟，在每次完成卡压后，活塞自动回缩，无需手动切换。
- 压接钳插销设计有弹簧装置，有效防止未锁紧的误操作。
- 衡力技术确保稳定的压接力。
- 橡胶手柄，整体重量分布平衡，长时间使用中无疲劳感。
- 电机驱动，搭载微型计算机控制系统和微型双级液压系统。
- The whole crimping process only takes a short time of 10 seconds at the fastest time. After each compression, the piston automatically retracts without manual switching.
- The latch of crimping pliers is designed with spring device to effectively prevent misoperation without locking.
- The balance force technology ensures stable pressure relay force.
- Rubber handle, the overall weight distribution is balanced, and there is no fatigue during long use.
- Motor driven, equipped with microcomputer control system and micro two-stage hydraulic system.



EB-1550Q

EMEADS[®]
ZHEJIANG EMEADS TOOLS CO., LTD

充电式液压卡压工具

CHARGING TYPE HYDRAULIC CLAMPING TOOL

随时随地 无线束缚

WIRELESS BONDAGE, ANYTIME, ANYWHERE

专用于消防碳钢管道、
燃气碳钢管道环压
最新技术方案。

It is specially used for the latest technical scheme of carbon steel pipeline for fire protection and carbon steel pipeline for gas.



铜管
Copper tube



燃气管道
Gas pipeline



消防管道
Fire fighting pipeline



电池 Battery



充电器 Charger

压模 Mold

技术参数 / TECHNICAL DATA:

卡压范围 Compression range:	12-54mm(1/2"-2") 碳钢管、薄壁不锈钢管、塑料管、铝塑复合管、铜管 12-54mm (1/2"-2") Carbon steel pipe, thin-wall stainless steel pipe, plastic pipe, aluminum plastic composite pipe, copper pipe	标配电池 Standard battery:	18V / 4.0Ah 锂电池 18V / 4.0Ah lithium battery
注意: 不同管件类型及材质, 卡压范围会有所变化, 具体应根据配套管件而定 Note: different pipe type and material, compression range will change, should be based on the specific supporting pipe		标配充电器 Standard charger:	AC 100V~240V 50~60Hz
额定出力 Rated output:	32KN (活塞出力 Piston output)	电池充电时间 Battery charging time:	约2小时 (About 2 hours)
行程 Trip:	40mm	保养周期 Maintenance cycle:	30000次(times)
单次卡压耗时 Time consumption of single clamping:	3-4.5s (根据管件的直径) 3-4.5s (According to the diameter of the pipe fitting)	每饱和电池卡压次数 Number of stuck voltage per saturated battery:	约350次 (DN20) About 350 times (DN20)
		重量 Weight:	3.9kg (工具带电池) 6.1kg (工具带电池和一副卡钳) 3.9kg (tool with battery) 6.1kg (tool with battery and a pair of calipers)
		工具尺寸 Tool dimensions:	450x81x128mm

配件 / ACCESSORIES:

电池 Battery:	2 pieces	充电器 Charger:	1 piece	模具配置 Mold configuration:	15, 20, 25, 32, 40, 50mm
-------------	----------	--------------	---------	--------------------------	--------------------------



进口电机 动力强劲

POWERFUL IMPORTED MOTOR

性能稳定可靠 性价比高

Stable performance, high cost performance



安全保障
Security



镀镍防锈压模
Nickel plated anti rust die



应用广泛
Widely used

产品特点 / PRODUCT FEATURES

- 整个压接过程最快仅需要短短的10秒钟，在每次完成卡压后，活塞自动回缩，无需手动切换。
- 压接钳插销设计有弹簧装置，有效防止未锁紧的误操作。
- 衡力技术确保稳定的压接力。
- 橡胶手柄，整体重量分布平衡，长时间使用中无疲劳感。
- 电机驱动，搭载微型计算机控制系统和微型双级液压系统。
- The whole crimping process only takes a short time of 10 seconds at the fastest time. After each compression, the piston automatically retracts without manual switching.
- The latch of crimping pliers is designed with spring device to effectively prevent misoperation without locking.
- The balance force technology ensures stable pressure relay force.
- Rubber handle, the overall weight distribution is balanced, and there is no fatigue during long use.
- Motor driven, equipped with microcomputer control system and micro two-stage hydraulic system.

EB-1632

EMEADS[®]
ZHEJIANG EMEADS TOOLS CO.,LTD

充电式液压卡压工具

CHARGING TYPE HYDRAULIC CLAMPING TOOL

另有型号可选：DE、DES无刷驱动
Other models: DE, DES brushless drive

随时随地 无线束缚

WIRELESS BONDAGE, ANYTIME, ANYWHERE

适用于卡压不锈钢水管，
消防碳钢管道、燃气碳钢管道、
多层复合管

The tool is applicable to stainless steel pipe, fire carbon steel pipe, gas carbon steel pipe and multi-layer composite pipe



铜管
Copper tube



多层复合管
Multilayer
composite tube



PEX管
PEX pipe



电池 Battery



不锈钢管
Stainless steel pipe



碳钢管
Carbon steel pipe



充电器 Charger

技术参数 / TECHNICAL DATA:

卡压范围 Compression range:	Φ16-32mm	标配电池 Standard battery:	18V / 4.0Ah 锂电池 18V / 4.0Ah lithium battery
注意：不同管件类型及材质，卡压范围会有所变化，具体应根据配套管件而定 Note: different pipe type and material, compression range will change, should be based on the specific supporting pipe		标配充电器 Standard charger:	AC 100V~240V 50~60Hz
额定出力 Rated output:	60KN (活塞出力) 60KN (Piston output)	压接次数 Crimping times:	320times (饱和电压) 320times (Per saturation voltage)
行程 Trip:	17mm	电池充电时间 Battery charging time:	约2小时 (About 2 hours)
单次卡压耗时 Time consumption of single clamping:	3-6s (根据管件的直径) 3-6s (According to the diameter of the pipe fitting)	毛重 Gross weight:	4.6kg
		包装 Package:	塑料盒 Plastic box

配件 / ACCESSORIES:

电池 Battery:	2 pieces	充电器 Charger:	1 piece	模具配置 Mold configuration:	16, 20, 25, 32mm
-------------	----------	--------------	---------	--------------------------	------------------

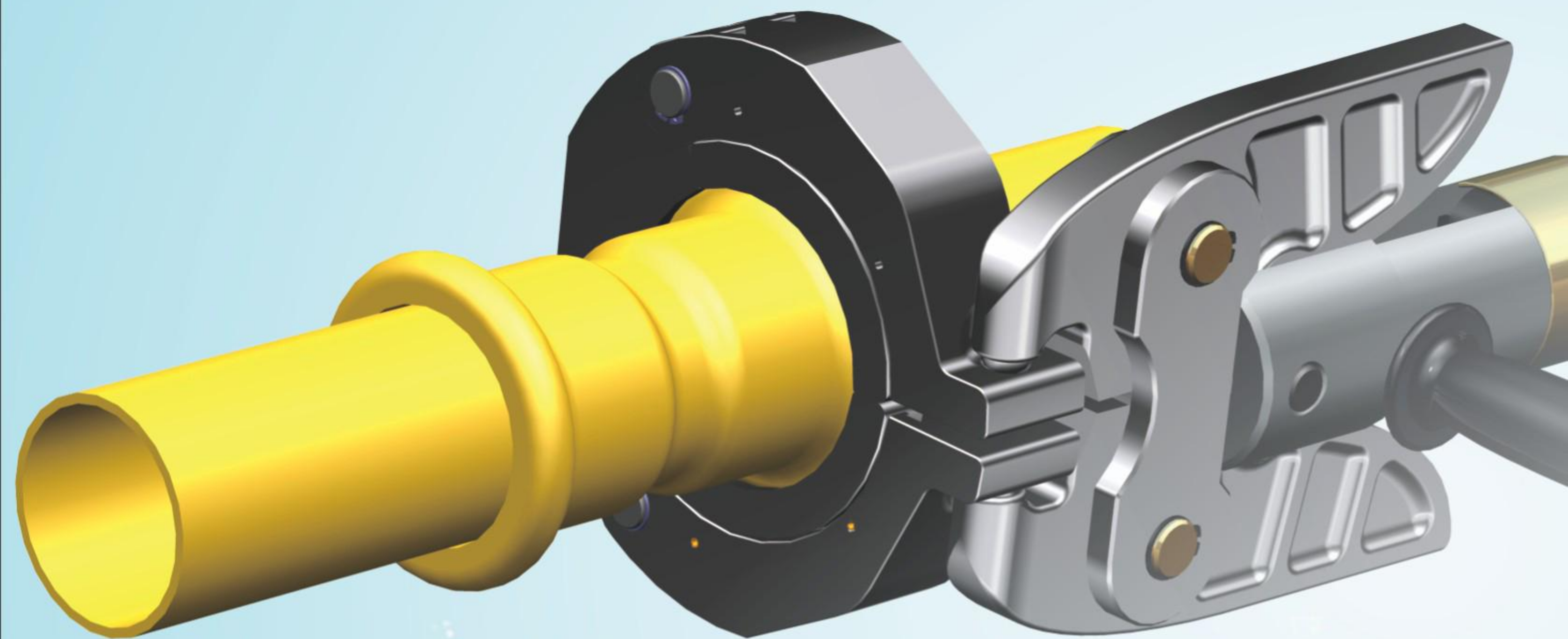

进口电机 动力强劲

POWERFUL IMPORTED MOTOR

将碳钢管表面涂层损伤降到最低!

Minimize coating damage on carbon steel pipes!



安全保障
Security



镀镍防锈压模
Nickel plated anti rust die



应用广泛
Widely used



产品特点 / PRODUCT FEATURES

- 整个压接过程最快仅需要短短的10秒钟，在每次完成卡压后，活塞自动回缩，无需手动切换。
- 压接钳插销设计有弹簧装置，有效防止未锁紧的误操作。
- 衡力技术确保稳定的压接力。
- 橡胶手柄，整体重量分布平衡，长时间使用中无疲劳感。
- 电机驱动，搭载微型计算机控制系统和微型双级液压系统。
- The whole crimping process only takes a short time of 10 seconds at the fastest time. After each compression, the piston automatically retracts without manual switching.
- The latch of crimping pliers is designed with spring device to effectively prevent misoperation without locking.
- The balance force technology ensures stable pressure relay force.
- Rubber handle, the overall weight distribution is balanced, and there is no fatigue during long use.
- Motor driven, equipped with microcomputer control system and micro two-stage hydraulic system.