

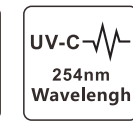

# GKU22-90W-03/05

# UVC PURIFICATION PANEL LIGHT

Panel light with UVC tube on both sides

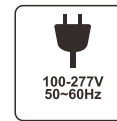
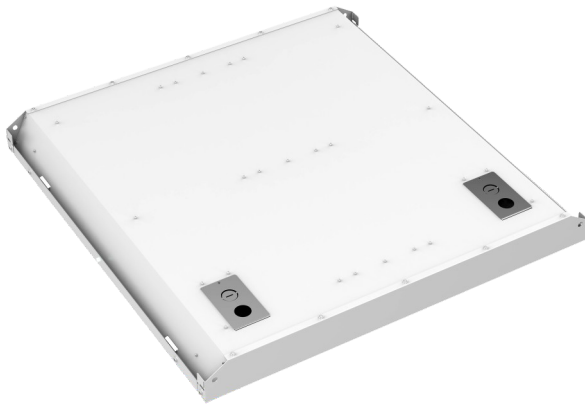
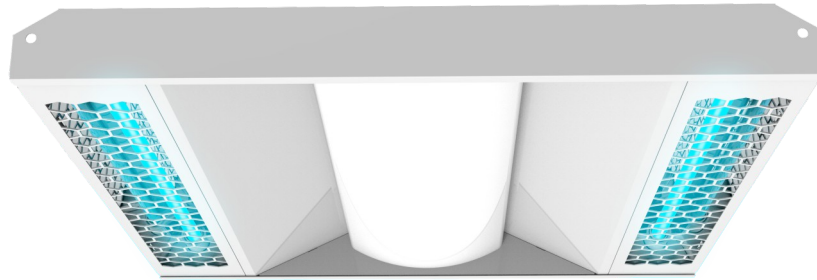

## Specification

Model	Watt		Input Voltage	Wavelength	Tube Type	LED CCT	LED Lumen	Dimension	Working Temperature (°C)	Warranty	Color
U22-90W-03	90W ± 10%	UVC:50W LED:40W	220-240V 50-60Hz	254nm	UVC	2700-5700K	4200-4600LM	595*595*57mm	-10~35°C	UVC:1year LED:3year	White
U22-90W-05		UVC:50W LED:40W									

## Features

**Feature 1: Delay start up to make sure that people have enough time to leave the area to be illuminated.**

Intelligent sensor: At start up, the main unit will count down 18 seconds. UV tubes will not start to work if the microwave sensor detects people and pets are in the area to be illuminated to prevent the injury from the exposure of UVC light.

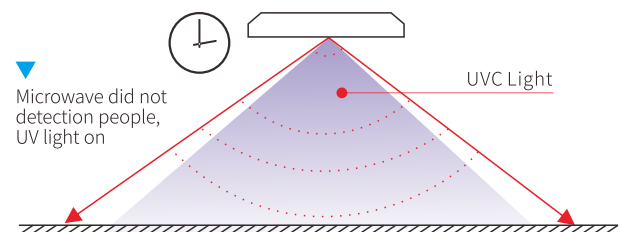
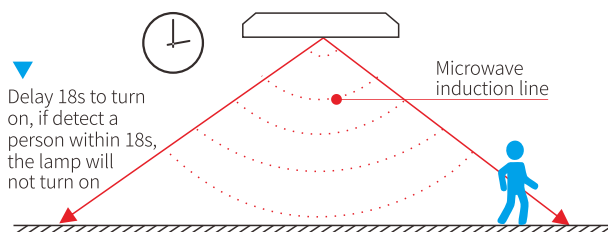

## Feature 2: Shut down automatically to prevent the potential threat to people and pets

Smart sensor: People and pets could accidentally enter the illuminated area while the device is active, The smart sensor will shut down the device immediately to protect people from the exposure of UVC light.

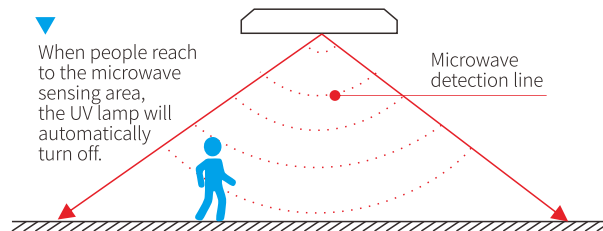
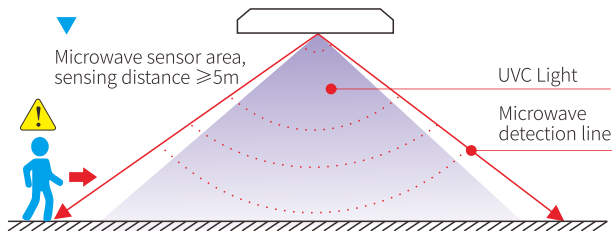

## Feature 3: Separated power control for LED and UVC

The control systems and power of UV and LED are separated to improve the safety of the device.

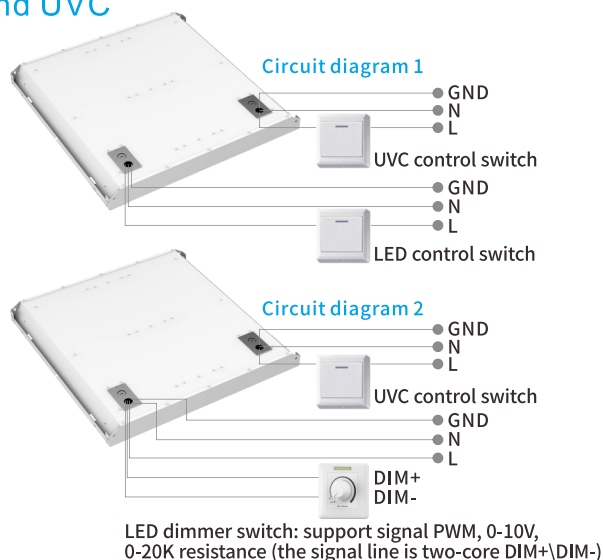
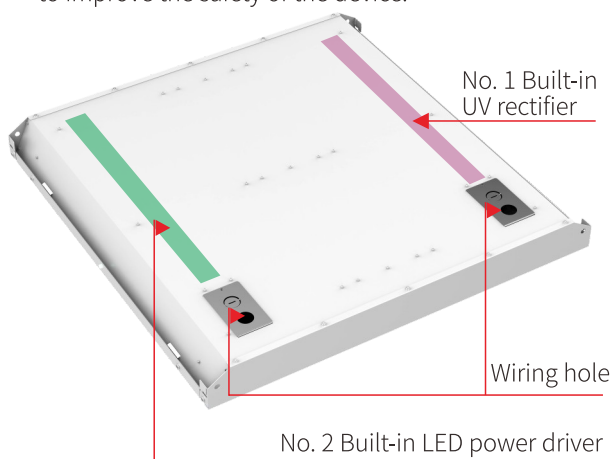

## Feature 4: Compatible with L32 control system

If someone enter the room unintentionally while the UV lamps are active, the lamps will be turned off automatically while the door opens. L32 control system work with the sensors together will provide you more safety.

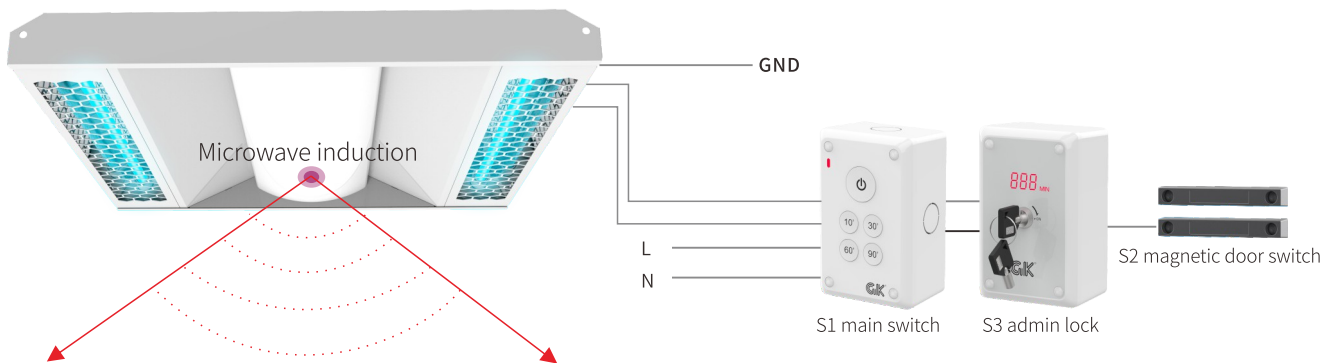

## Feature 5: UV glass lamp protection design

1. Prevent the UVC lamp is not installed securely and falls off.
2. Prevent the installation of moving lamps and damage the lamp tubes.
3. Prevent UVC lamp from being broken by objects

Aluminum wire-guard protection

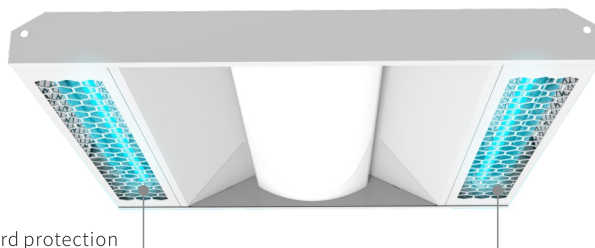

## Feature 6-UV two control modes

Mode 1-Normal mode.

Mode 2-Remote control mode.

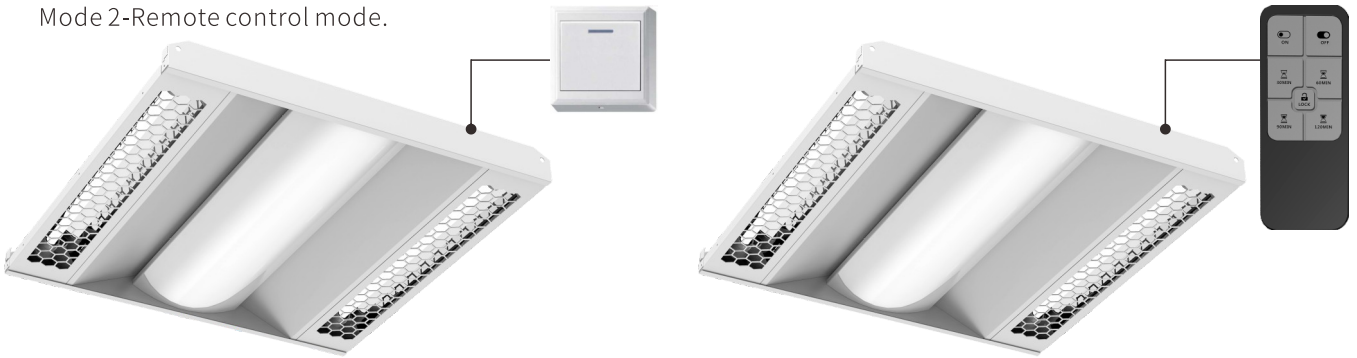

## Replace the UVC tube

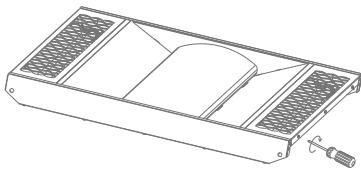

1. Use a screwdriver to remove the screws on the mesh cover plate.

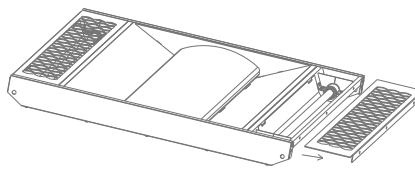

2. Remove the mesh cover plate.

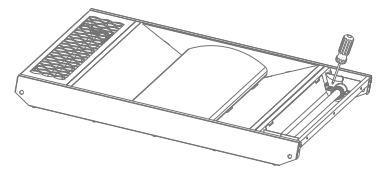

3. Use a screwdriver to remove the screws on the UVC tube clasp, pull out the wire and replace the tube with a new one.

## Installation

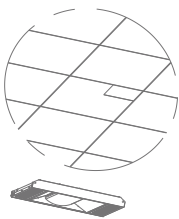

1. Choose the location you want to install.

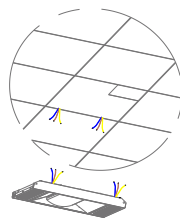

2. Connect the UVC tube and LED on two switches respectively.

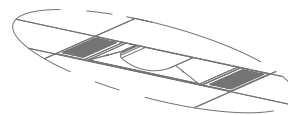

3. Install the lamp properly.

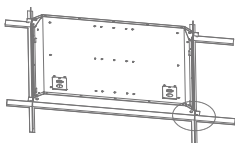

4. Then open the 4 rear side safety buckles at 90°

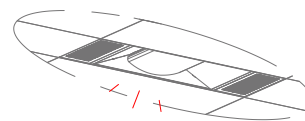
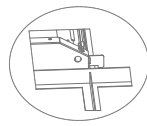

5. Turn on the switch to light the lamp.

## Dimensions

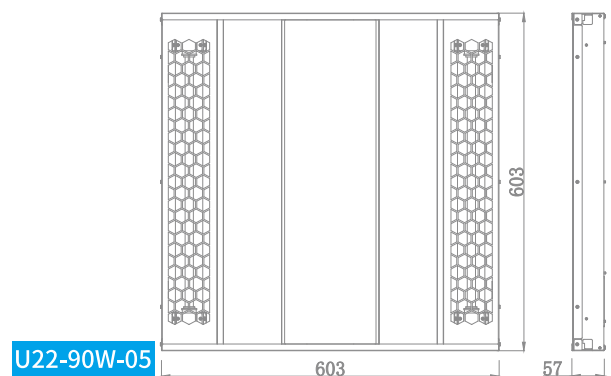
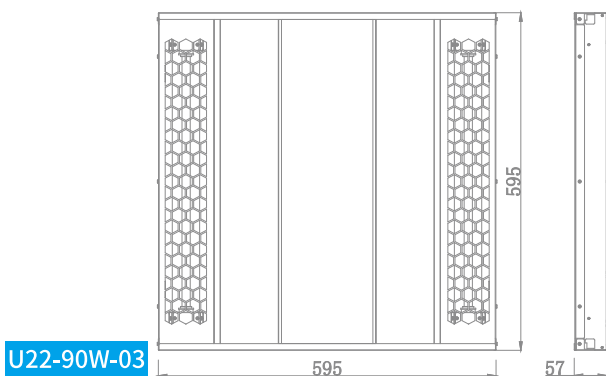

# Application



Effective killing rate of Enterobacter 99.9%

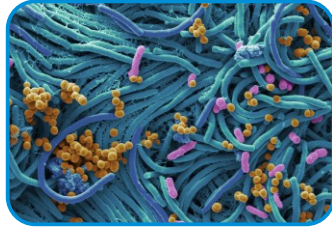

Effective killing Staphylococcus aureus is 99.9%



Effective elimination rate of Corona-virus is 99.9%

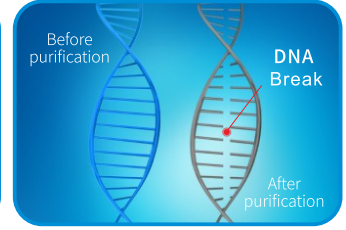

Diagram of UV purification principles



# Packing

Model	NW(kg) (lbs=kgx2.2)	GW(kg) (lbs=kgx2.2)	Carton Size (mm) (x0.0393=inch)	Quantity per carton
U22-90W-03	4.88KG	7.00KG	675*660*120mm	1PCS
U22-90W-05	5.01KG	7.20KG	685*670*120mm	1PCS

## Packing details

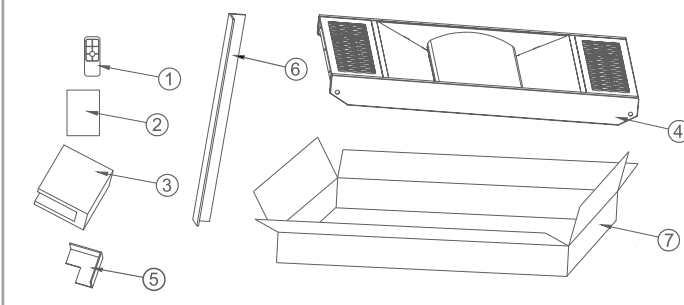

No	Name	Quantity	Configuration
1	Remote control	1	Standard
2	Manual	1	Standard
3	Pearl cotton	4	Standard
4	Fixture	1	Standard
5	Paper card	4	Standard
6	Corner protector	4	Standard
7	Carton	1	Standard

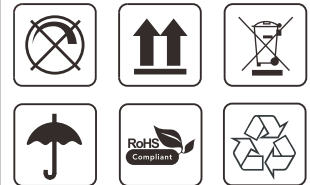

**GK** SHENZHEN GUANKE TECHNOLOGIES CO.,LTD

Bldg 34, XiaLang Industrial Zone, HeShuiKou Community, MaTian St., GuangMing Dist., ShenZhen 518106, China

Tel: +86-755-27165559  
E-mail: cooper@gkuvc.com

Fax: +86-755-27543939  
Web: www.gkuvc.com