

益詮切削刀具

ECHAINTOOL Cutting Tools
ECHAINTOOL Cutting Tools

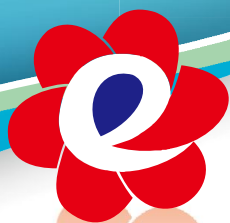

CHAIN®



台灣精品 2008
TAIWAN EXCELLENCE



設計優良產品
GOOD DESIGN PRODUCT



住友電工 中國一級代理
Sumitomo Agent in China

中心出水系列

COOLANT THRU SPINDLE SERIES



Our web



益詮精密股份有限公司 ECHAINTOOL PRECISION CO., LTD.

TEL:+886-4-22710856 FAX:+886-4-22710857
Skype : echaintool
E-mail : sales@echaintool.com
https : //www.echaintool.com
41154 台灣台中市太平區大里工業區工業18路3-1號
No.3-1, Gongye 18th Rd., Taiping Dist., Taichung City,
41154, Taiwan (Da-Li Industrial Park)

中国总部 Branch In China 企业QQ : 400-606-5118
National Free Call Number (In China) : 400-606-5118
TEL : +86-0512-57005208 FAX : +86-0512-57005206
业务投诉专线 : 18020216088
广东 / 天津 / 重庆 / 武汉 均有办事处
Branch offices are located at Guangdong, Tainjin, Chongqing and Wuhan.

外徑中心出水車刀 Centre Coolant Fed Clamp Tool Holder

已通過美國發明專利
U.S. patent.



30 Bar Mini
300 Bar Max

全球獨步下壓板引導式水孔
Globally stepped down platen-type water hole.



可由刀架側面及刀架下方皆可接入高壓水管

High pressure water pipes can be accessed from the side of the tool holder or under the tool holder.

- ◆ 近距離噴射中心出水，強效降低切削所產生的熱能
Close-range center jetting water, strengthen the heat energy generated during cutting.
- ◆ 高壓出水加強斷屑效果，使排屑順暢，避免捲屑問題
High-pressure effluent strengthens the chip breaking effect.
- ◆ 中心銷精準定位，大壓板加強固定
Screw of shim precise positioning, large clamp to strengthen.
- ◆ 可承受輕、中、重切削加工，尺寸穩定
Precision positioning for light cutting, medium cutting, heavy cutting.



雙向直噴水孔系列

Two-way direct injection water hole series.



CNMG120404/08-IO-ECP200

適用材質
Processing on

合金鋼
Alloy Steel



TNMG160404/08-IO-ECP200

不鏽鋼
Stainless Steel



WNMG080404/08-IO-ECP200

鑄鐵
Cast Iron

外徑中心出水車刀 Centre Coolant Fed Clamp Tool Holder

HCLN

75°



| 產品型號 Model No | 柄徑 AxB Shank Dia | 全長 L O.A.L | 加工深度 E Processing Depth | 刀尖距離 F Tip Distance |
|-----------------|---------------------|---------------|----------------------------|------------------------|
| HCLNR/L-2525M12 | 25 x 25 | 150 | 34 | 32 |

◆ 刀片 Insert : CN□□1204□□

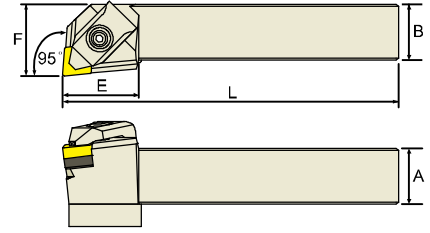

HCMN

75°

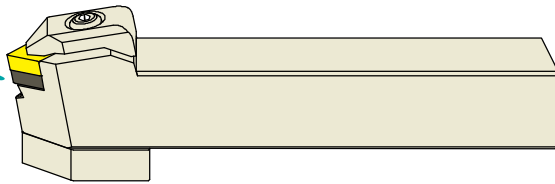

| 產品型號 Model No | 柄徑 AxB Shank Dia | 全長 L O.A.L | 加工深度 E Processing Depth | 刀尖距離 F Tip Distance |
|---------------|---------------------|---------------|----------------------------|------------------------|
| HCMNN-2525M12 | 25 x 25 | 150 | 38 | 12,5 |

◆ 刀片 Insert : CN□□1204□□

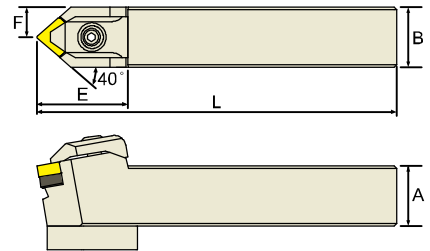

HCRN

95°

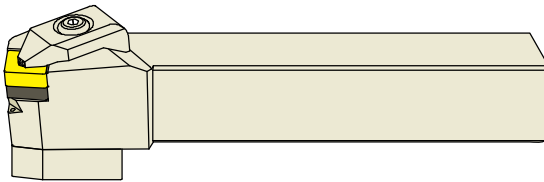

| 產品型號 Model No | 柄徑 AxB Shank Dia | 全長 L O.A.L | 加工深度 E Processing Depth | 刀尖距離 F Tip Distance |
|-----------------|---------------------|---------------|----------------------------|------------------------|
| HCRNR/L-2525M12 | 25 x 25 | 150 | 44 | 32 |

◆ 刀片 Insert : CN□□1204□□

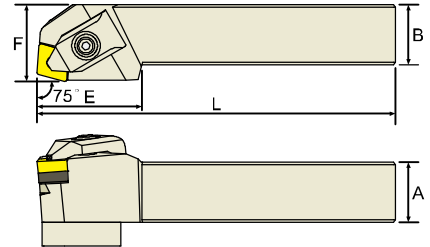

HCKN

40°

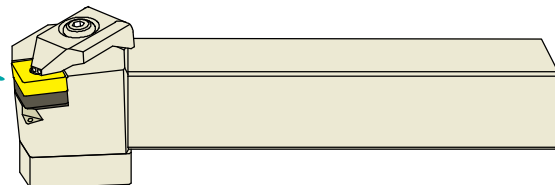

| 產品型號 Model No | 柄徑 AxB Shank Dia | 全長 L O.A.L | 加工深度 E Processing Depth | 刀尖距離 F Tip Distance |
|-----------------|---------------------|---------------|----------------------------|------------------------|
| HCKNR/L-2525M12 | 25 x 25 | 150 | 34 | 32 |

◆ 刀片 Insert : CN□□1204□□

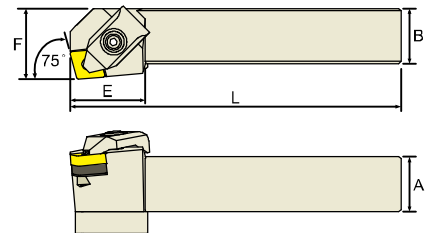



外徑中心出水車刀 Centre Coolant Fed Clamp Tool Holder

HTJN

93°



| 產品型號 Model No | 柄徑 AxB Shank Dia | 全長 L O.A.L | 加工深度 E Processing Depth | 刀尖距離 F Tip Distance |
|-----------------|---------------------|---------------|----------------------------|------------------------|
| HTJNR/L-2525M16 | 25 x 25 | 150 | 34 | 32 |

◆ 刀片 Insert : TN□□1604□□

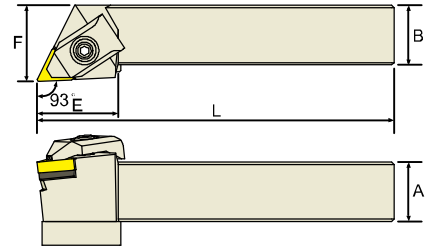

HTEN

60°

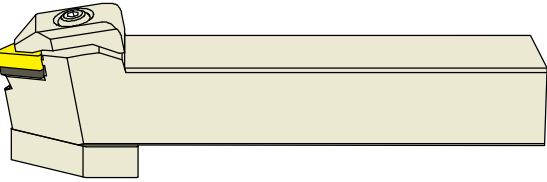

| 產品型號 Model No | 柄徑 AxB Shank Dia | 全長 L O.A.L | 加工深度 E Processing Depth | 刀尖距離 F Tip Distance |
|---------------|---------------------|---------------|----------------------------|------------------------|
| HTENN-2525M16 | 25 x 25 | 150 | 38 | 12.5 |

◆ 刀片 Insert : TN□□1604□□

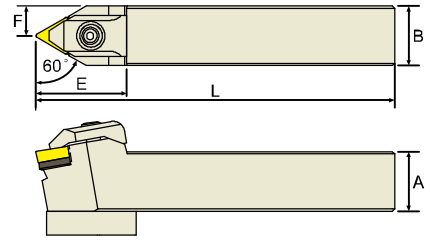

HTFN

91°

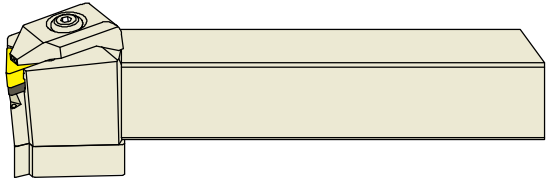

| 產品型號 Model No | 柄徑 AxB Shank Dia | 全長 L O.A.L | 加工深度 E Processing Depth | 刀尖距離 F Tip Distance |
|-----------------|---------------------|---------------|----------------------------|------------------------|
| HTFNR/L-2525M16 | 25 x 25 | 150 | 34 | 32 |

◆ 刀片 Insert : CN□□1604□□

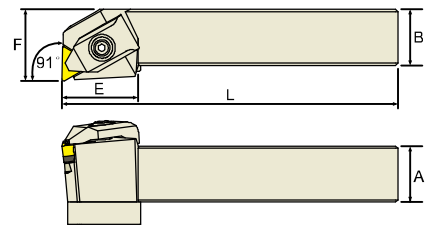

HTGN

90°

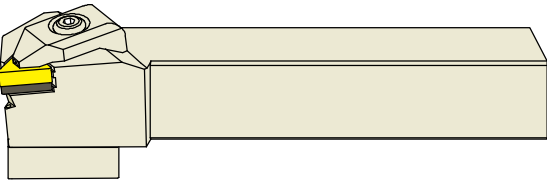

| 產品型號 Model No | 柄徑 AxB Shank Dia | 全長 L O.A.L | 加工深度 E Processing Depth | 刀尖距離 F Tip Distance |
|-----------------|---------------------|---------------|----------------------------|------------------------|
| HTGNR/L-2525M16 | 25 x 25 | 150 | 44 | 32 |

◆ 刀片 Insert : CN□□1604□□

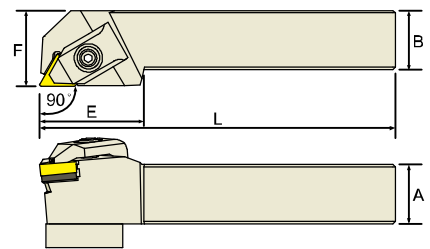

HTQN

105°

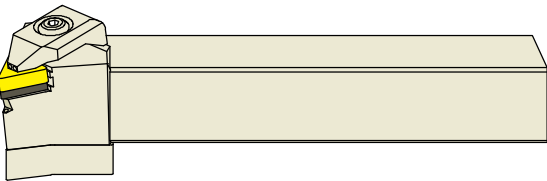

| 產品型號 Model No | 柄徑 AxB Shank Dia | 全長 L O.A.L | 加工深度 E Processing Depth | 刀尖距離 F Tip Distance |
|-----------------|---------------------|---------------|----------------------------|------------------------|
| HTQNR/L-2525M16 | 25 x 25 | 150 | 34 | 32 |

◆ 刀片 Insert : CN□□1604□□

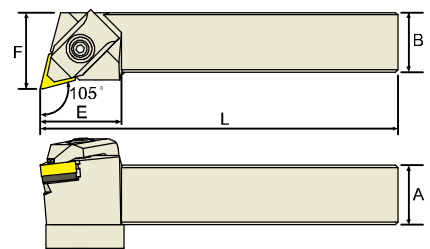

外徑中心出水車刀 Centre Coolant Fed Clamp Tool Holder

HSDN

45°

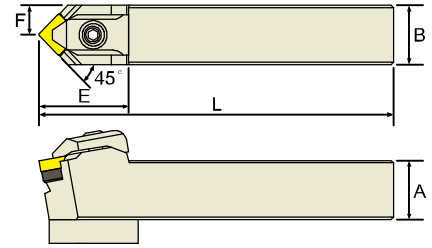
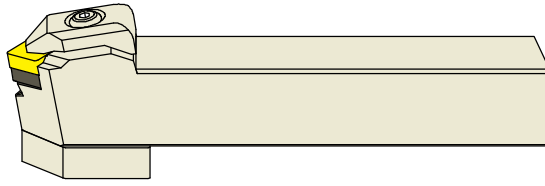

| 產品型號 Model No | 柄徑 AxB Shank Dia | 全長 L O.A.L | 加工深度 E Processing Depth | 刀尖距離 F Tip Distance |
|---------------|---------------------|---------------|----------------------------|------------------------|
| HSDNN-2525M12 | 25 x 25 | 150 | 38 | 12.5 |

◆ 刀片 Insert : SN□□1204□□

HSBN

75°

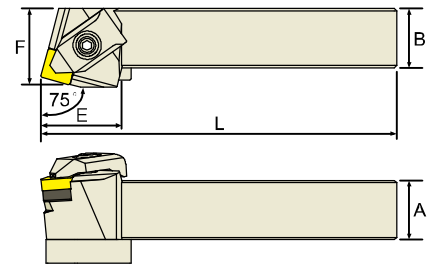
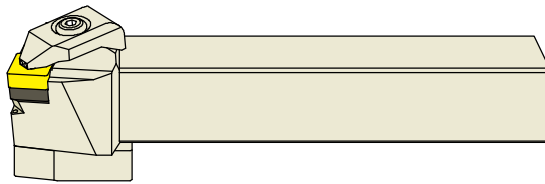

| 產品型號 Model No | 柄徑 AxB Shank Dia | 全長 L O.A.L | 加工深度 E Processing Depth | 刀尖距離 F Tip Distance |
|----------------|---------------------|---------------|----------------------------|------------------------|
| HSBNR/L2525M12 | 25 x 25 | 150 | 34 | 32 |

◆ 刀片 Insert : SN□□1204□□

HSKN

75°

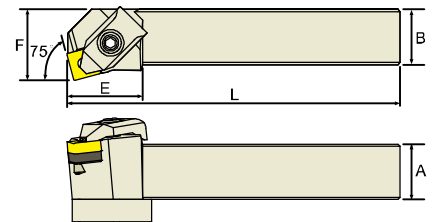
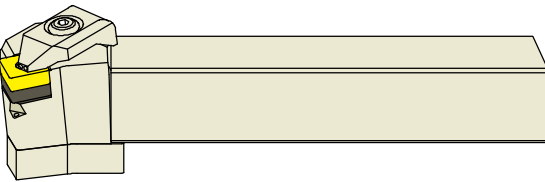

| 產品型號 Model No | 柄徑 AxB Shank Dia | 全長 L O.A.L | 加工深度 E Processing Depth | 刀尖距離 F Tip Distance |
|----------------|---------------------|---------------|----------------------------|------------------------|
| HSKNR/L2525M12 | 25 x 25 | 150 | 34 | 32 |

◆ 刀片 Insert : SN□□1204□□

HSSN

45°

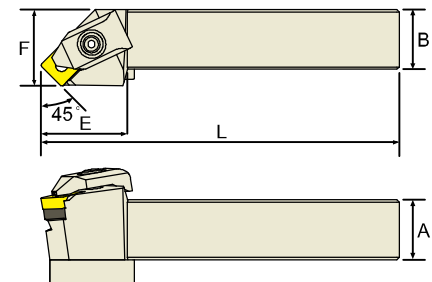
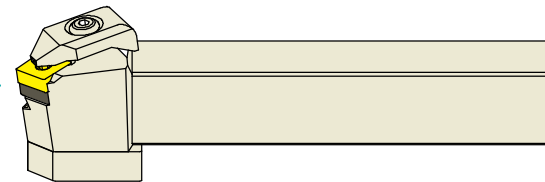

| 產品型號 Model No | 柄徑 AxB Shank Dia | 全長 L O.A.L | 加工深度 E Processing Depth | 刀尖距離 F Tip Distance |
|-----------------|---------------------|---------------|----------------------------|------------------------|
| HSSNR/L-2525M12 | 25 x 25 | 150 | 36 | 32 |

◆ 刀片 Insert : SN□□1204□□





外徑中心出水車刀 Centre Coolant Fed Clamp Tool Holder

HVJN

93°

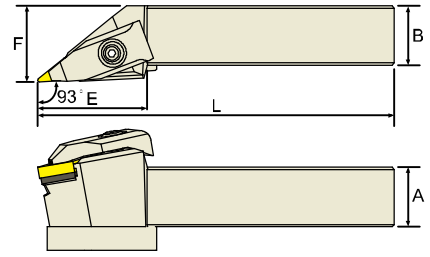
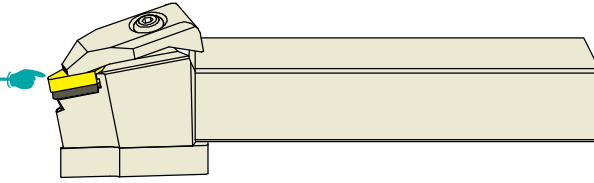

| 產品型號 Model No | 柄徑 AxB Shank Dia | 全長 L O.A.L | 加工深度 E Processing Depth | 刀尖距離 F Tip Distance |
|-----------------|---------------------|---------------|----------------------------|------------------------|
| HVJNR/L-2525M16 | 25 x 25 | 150 | 46 | 32 |

◆ 刀片 Insert : VN□□1604□□

HVVNN

72.5°

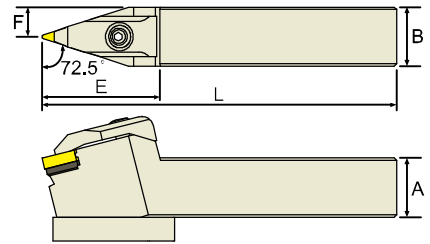
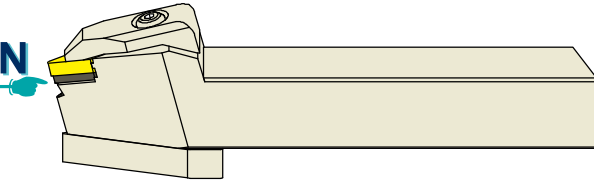

| 產品型號 Model No | 柄徑 AxB Shank Dia | 全長 L O.A.L | 加工深度 E Processing Depth | 刀尖距離 F Tip Distance |
|---------------|---------------------|---------------|----------------------------|------------------------|
| HVVNN-2525M16 | 25 x 25 | 150 | 50 | 12.5 |

◆ 刀片 Insert : VN□□1604□□

HVVNR

72.5°

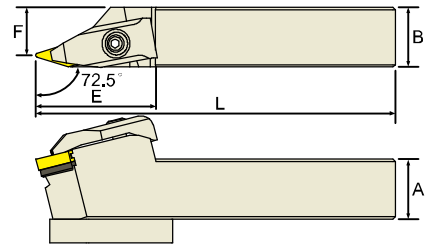
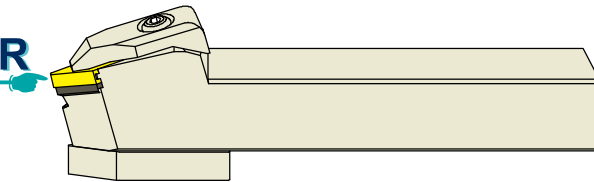

| 產品型號 Model No | 柄徑 AxB Shank Dia | 全長 L O.A.L | 加工深度 E Processing Depth | 刀尖距離 F Tip Distance |
|-----------------|---------------------|---------------|----------------------------|------------------------|
| HVVNR/L-2525M16 | 25 x 25 | 150 | 50 | 20 |

◆ 刀片 Insert : VN□□1604□□

HVQN

117.5°

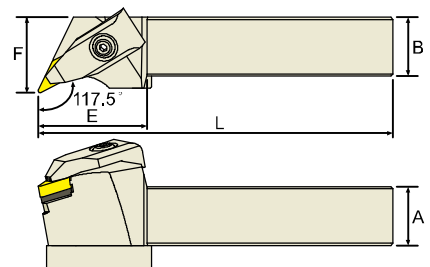
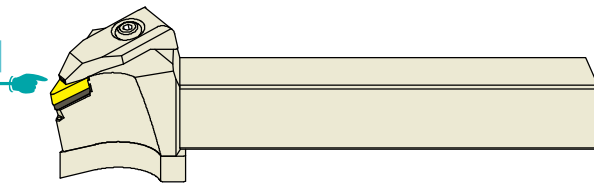

| 產品型號 Model No | 柄徑 AxB Shank Dia | 全長 L O.A.L | 加工深度 E Processing Depth | 刀尖距離 F Tip Distance |
|-----------------|---------------------|---------------|----------------------------|------------------------|
| HVQNR/L-2525M16 | 25 x 25 | 150 | 46 | 32 |

◆ 刀片 Insert : VN□□1604□□

外徑中心出水車刀 Centre Coolant Fed Clamp Tool Holder

HWLN

95°



| 產品型號 Model No | 柄徑 AxB Shank Dia | 全長 L O.A.L | 加工深度 E Processing Depth | 刀尖距離 F Tip Distance |
|----------------|---------------------|---------------|----------------------------|------------------------|
| HWLN/L-2525M08 | 25 x 25 | 150 | 34 | 32 |

◆ 刀片 Insert : WN□□0804□□

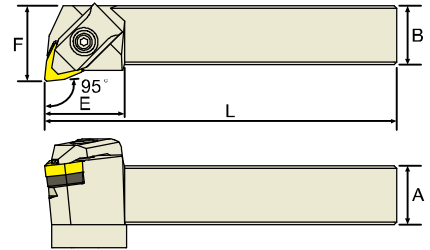

HDJN

93°

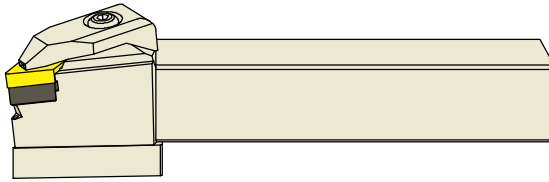

| 產品型號 Model No | 柄徑 AxB Shank Dia | 全長 L O.A.L | 加工深度 E Processing Depth | 刀尖距離 F Tip Distance |
|-----------------|---------------------|---------------|----------------------------|------------------------|
| HDJNR/L-2525M15 | 25 x 25 | 150 | 36 | 32 |

◆ 刀片 Insert : DN□□1504□□

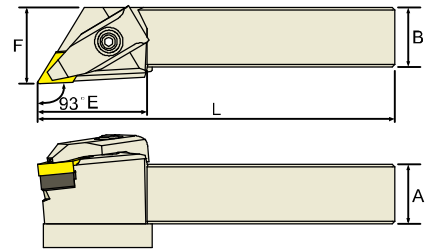

HDQN

107.5°

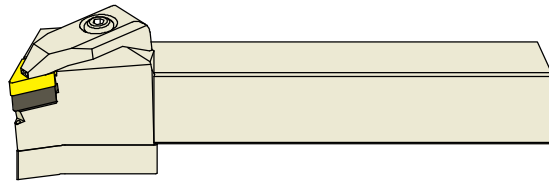

| 產品型號 Model No | 柄徑 AxB Shank Dia | 全長 L O.A.L | 加工深度 E Processing Depth | 刀尖距離 F Tip Distance |
|----------------|---------------------|---------------|----------------------------|------------------------|
| HDQNR/L2525M15 | 25 x 25 | 150 | 46 | 32 |

◆ 刀片 Insert : DN□□1504□□

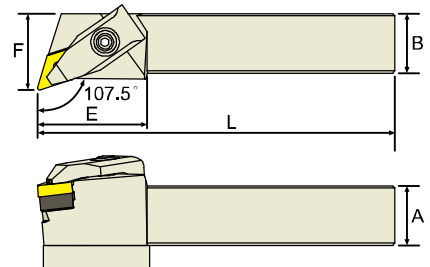

HDNN

45°

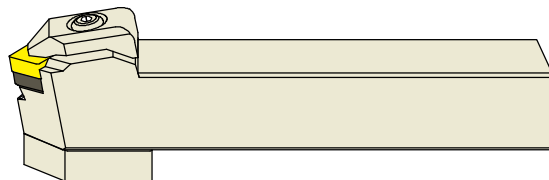

| 產品型號 Model No | 柄徑 AxB Shank Dia | 全長 L O.A.L | 加工深度 E Processing Depth | 刀尖距離 F Tip Distance |
|---------------|---------------------|---------------|----------------------------|------------------------|
| HDNNN-2525M15 | 25 x 25 | 150 | 50 | 12.5 |

◆ 刀片 Insert : DN□□1504□□

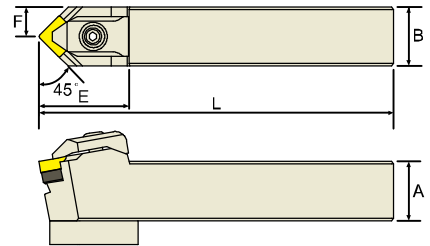

模具鋼抗震刀柄中心出水內徑車刀

Alloy Tool Steel Shank Central Coolant With Oil Hole Boring Bar

中心出水式 Central coolant

中心出水加強冷卻降溫及排屑效果

Strengthen the cooling and chip removal effect

有效提升刀片加工壽命

Improve insert processing life efficiently.

可四倍抗震

It's Quadruple Seismic Performance

- ◆ 高鋼性SKD61材質
High Rigid SKD61 material.
- ◆ 中心出水方式可加強冷卻及排屑效果
Central coolant system, strengthen the cooling and chip removal effect.
- ◆ 有效提升刀片加工壽命
Improve insert processing life effectively.

改善一般外徑出水無法沖至刀尖缺點
提升刀片加工壽命，可強制排出鐵屑
避免因捲屑導致的刀具損壞

The advanced design of the coolant hole can enhance the stability of the inserts by helping the chip discharge effectively and the coolant can reach the top edge of the inserts.

With less chip, the holder itself can avoid the damage caused by the stuck chip.



模具鋼抗震刀柄中心出水內徑車刀 Alloy Tool Steel Shank Central Coolant With Oil Hole Boring Bar

SCLC

95°

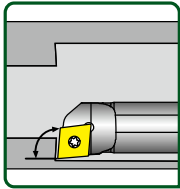

| 產品型號 Model No | 加工徑 ØB Min. Bore Dia. | 柄徑 D Shank Dia | 刀尖距離 F Tip Distance | 全長 L O.A.L | 刀片 Insert |
|---------------------|--------------------------|-------------------|------------------------|---------------|------------|
| H08K-SCLCR/L06-10-O | 10 | 8 | 5.5 | 125 | CN□□0602□□ |
| H10K-SCLCR/L06-12-O | 12 | 10 | 6 | 125 | CN□□0602□□ |
| H12M-SCLCR/L06-14-O | 14 | 12 | 7 | 150 | CN□□0602□□ |
| H12M-SCLCR09-16-O | 16 | 12 | 8.5 | 150 | CN□□09T3□□ |
| H16Q-SCLCR/L09-18-O | 18 | 16 | 9 | 180 | CN□□09T3□□ |
| H20R-SCLCR/L09-22-O | 22 | 20 | 11 | 200 | CN□□09T3□□ |
| H25R-SCLCR/L09-O | 32 | 25 | 17 | 200 | CN□□09T3□□ |

STUP

93°

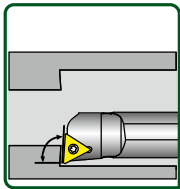

| 產品型號 Model No | 加工徑 ØB Min. Bore Dia. | 柄徑 D Shank Dia | 刀尖距離 F Tip Distance | 全長 L O.A.L | 刀片 Insert |
|----------------------|--------------------------|-------------------|------------------------|---------------|------------|
| H08K-STUPR/L08-10-O | 10 | 8 | 5.5 | 125 | TP□□0802□□ |
| H08K-STUPR/L09-10-O | 10 | 8 | 5.5 | 125 | TP□□0902□□ |
| H10K-STUPR/L09-12-O | 12 | 10 | 6 | 125 | TP□□0902□□ |
| H12M-STUPR/L09-14-O | 14 | 12 | 7 | 150 | TP□□0902□□ |
| H10K-STUPR/L11-12-O | 12 | 10 | 6 | 125 | TP□□1103□□ |
| H12M-STUPR/L11-14-O | 14 | 12 | 7 | 150 | TP□□1103□□ |
| H16Q-STUPR/L11-18-O | 18 | 16 | 9 | 180 | TP□□1103□□ |
| H20R-STUPR/L11-22-O | 22 | 20 | 11 | 200 | TP□□1103□□ |
| H25R-STUPRP/L11-28-O | 28 | 25 | 14 | 200 | TP□□1103□□ |

SDUC

93°

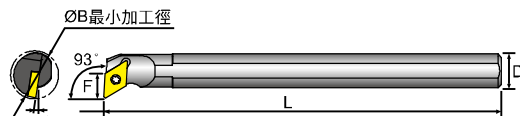
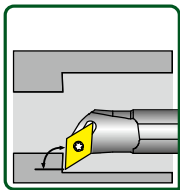

| 產品型號 Model No | 加工徑 ØB Min. Bore Dia. | 柄徑 D Shank Dia | 刀尖距離 F Tip Distance | 全長 L O.A.L | 刀片 Insert |
|------------------|--------------------------|-------------------|------------------------|---------------|------------|
| H10K-SDUCR/L07-O | 14 | 10 | 8 | 125 | DC□□0702□□ |
| H12M-SDUCR/L07-O | 16 | 12 | 9 | 150 | DC□□0702□□ |
| H16Q-SDUCR/L07-O | 20 | 16 | 11 | 180 | DC□□0702□□ |
| H16Q-SDUCR/L11-O | 20 | 16 | 11 | 180 | DC□□11T3□□ |
| H20R-SDUCR/L11-O | 25 | 20 | 13 | 200 | DC□□11T3□□ |
| H25R-SDUCR/L11-O | 32 | 25 | 17 | 200 | DC□□11T3□□ |

SDQC

107.5°

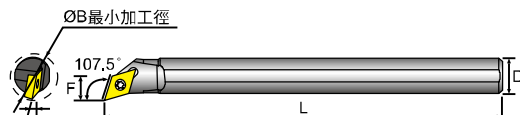
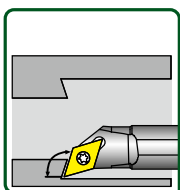

| 產品型號 Model No | 加工徑 ØB Min. Bore Dia. | 柄徑 D Shank Dia | 刀尖距離 F Tip Distance | 全長 L O.A.L | 刀片 Insert |
|------------------|--------------------------|-------------------|------------------------|---------------|------------|
| H10K-SDQCR/L07-O | 13 | 10 | 7 | 125 | DC□□0702□□ |
| H12M-SDQCR/L07-O | 16 | 12 | 9 | 150 | DC□□0702□□ |
| H16Q-SDQCR/L07-O | 20 | 16 | 11 | 180 | DC□□0702□□ |
| H16Q-SDQCR/L11-O | 20 | 16 | 11 | 180 | DC□□11T3□□ |
| H20R-SDQCR/L11-O | 25 | 20 | 13 | 200 | DC□□11T3□□ |
| H25R-SDQCR/L11-O | 32 | 25 | 17 | 200 | DC□□11T3□□ |



CN



TN



DN

■ 模具鋼抗震刀柄中心出水 微小徑內孔加工車刀

Alloy Tool Steel Shank Mini Boring Bar
Central Coolant With Oil Hole Boring Bar

改善一般外徑出水無法沖至刀尖缺點，提升刀片加工壽命
可強制排出鐵屑，避免因捲屑導致的刀具損壞。

The advanced design of the coolant hole can enhance the stability of the inserts by helping the chip discharge effectively and the coolant can reach the top edge of the inserts. With less chip, the holder itself can avoid the damage caused by the stuck chip.

SCLC

95°

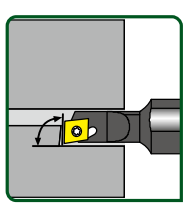

| 產品型號 Model No | 加工徑 ØB Min. Bore Dia. | D | d | F | H | L | L1 |
|------------------|--------------------------|----|----|---|----|-----|----|
| A0608H-SCLCR/L06 | 8 | 8 | 7 | 4 | 7 | 100 | 25 |
| A0810J-SCLCR/L06 | 12 | 10 | 8 | 6 | 9 | 110 | 32 |
| A1012K-SCLCR/L06 | 14 | 12 | 10 | 7 | 11 | 125 | 38 |
| A1216M-SCLCR/L06 | 18 | 16 | 12 | 9 | 15 | 150 | 50 |

◆ 刀片 Insert : CC□□0602□□

STFC

91°

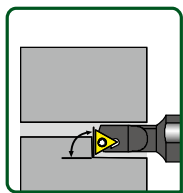

| 產品型號 Model No | 加工徑 ØB Min. Bore Dia. | D | d | F | H | L | L1 |
|------------------|--------------------------|----|----|----|----|-----|----|
| A0810J-STFCR/L11 | 14 | 8 | 7 | 7 | 9 | 110 | 32 |
| A1012K-STFCR/L11 | 18 | 10 | 9 | 9 | 11 | 125 | 38 |
| A1216M-STFCR/L11 | 22 | 12 | 11 | 11 | 15 | 150 | 50 |

◆ 刀片 Insert : TC□□1102□□

SDUC

93°

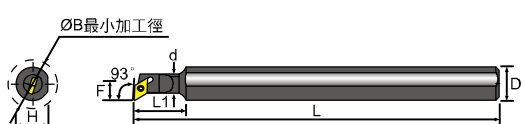
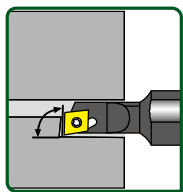

| 產品型號 Model No | 加工徑 ØB Min. Bore Dia. | D | d | F | H | L | L1 |
|------------------|--------------------------|----|----|---|----|-----|----|
| A0810J-SDUCR/L07 | 12.5 | 10 | 8 | 5 | 9 | 110 | 22 |
| A1012K-SDUCR/L07 | 15.5 | 12 | 10 | 9 | 11 | 125 | 28 |
| A1216M-SDUCR/L07 | 19.5 | 16 | 12 | 5 | 15 | 150 | 36 |

◆ 刀片 Insert : DC□□0702□□

SDQC

107.5°

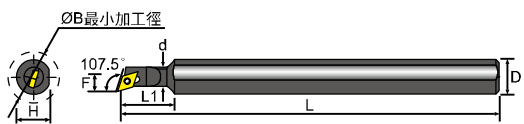
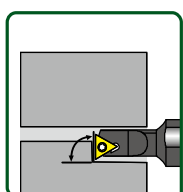

| 產品型號 Model No | 加工徑 ØB Min. Bore Dia. | D | d | F | H | L | L1 |
|------------------|--------------------------|----|----|----|----|-----|----|
| A0810J-SDQCR/L07 | 14 | 10 | 8 | 7 | 9 | 110 | 22 |
| A1012K-SDQCR/L07 | 18 | 12 | 10 | 9 | 11 | 125 | 28 |
| A1216M-SDQCR/L07 | 22 | 16 | 12 | 11 | 15 | 150 | 36 |

◆ 刀片 Insert : DC□□0702□□

10



CN



TN



DN

模具鋼抗震刀柄壓板固定式中心出水內徑車刀

Alloy Tool Steel Shank top clamping Central Coolant With Oil Hole Boring Bar

四倍抗震 It's Quadruple Seismic Performance

中心出水設計

Central coolant With Oil Hole design

中心出水加強冷卻降溫及排屑效果，有效提升刀片加工壽命
Strengthen the cooling and chip removal effect, Improve insert processing life efficiently.



壓板固定式中心出水內徑車刀 Alloy Tool Steel Shank top clamping Central Coolant With Oil Hole Boring Bar

ECLN · MCLN

95°

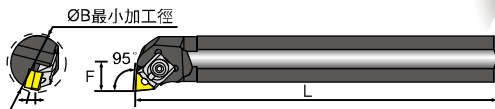
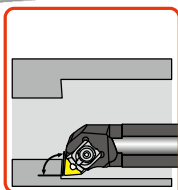

| 產品型號 Model No | 加工徑 ØB Min. Bore Dia. | 柄徑 D Shank Dia. | 刀尖距離 F Tip Distance | 全長 L O.A.L. | 刀片 Insert |
|------------------|--------------------------|--------------------|------------------------|----------------|------------|
| H32S-ECLNR/L12-O | 40 | 32 | 22 | 250 | CN□□1204□□ |
| H32U-ECLNR/L12-O | 40 | 32 | 22 | 250 | CN□□1204□□ |
| H20R-MCLNR/L09-O | 25 | 20 | 13 | 200 | CN□□0903□□ |
| H20R-MCLNR/L12-O | 25 | 20 | 13 | 200 | CN□□1204□□ |
| H25R-MCLNR/L12-O | 32 | 25 | 17 | 200 | CN□□1204□□ |
| H32S-MCLNR/L12-O | 40 | 32 | 22 | 250 | CN□□1204□□ |
| H32U-MCLNR/L12-O | 40 | 32 | 22 | 350 | CN□□1204□□ |

ETUN · MTUN

93°

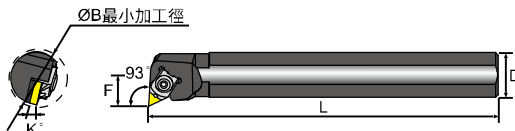
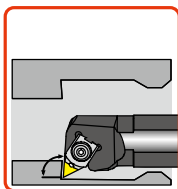

| 產品型號 Model No | 加工徑 ØB Min. Bore Dia. | 柄徑 D Shank Dia. | 刀尖距離 F Tip Distance | 全長 L O.A.L. | 刀片 Insert |
|-------------------|--------------------------|--------------------|------------------------|----------------|------------|
| H25R-ETUNR/L16-O | 32 | 25 | 17 | 200 | TN□□1604□□ |
| H25T-ETUNR/L16-O | 32 | 25 | 17 | 300 | TN□□1604□□ |
| H32S-ETUNR/L16-O | 40 | 32 | 22 | 250 | TN□□1604□□ |
| H32U-ETUNR/L16-O | 40 | 32 | 22 | 350 | TN□□1604□□ |
| H16Q-MTUNR/L16A-O | 22 | 16 | 11 | 180 | TN□□1604□□ |
| H20R-MTUNR/L16-O | 25 | 20 | 13 | 200 | TN□□1604□□ |
| H20R-MTUNR/L16A-O | 25 | 20 | 13 | 200 | TN□□1604□□ |
| H25R-MTUNR/L16-O | 32 | 25 | 17 | 200 | TN□□1604□□ |
| H25R-MTUNR/L16A-O | 32 | 25 | 17 | 200 | TN□□1604□□ |
| H32S-MTUNR/L16A-O | 40 | 32 | 22 | 250 | TN□□1604□□ |
| H40T-MTUNR/L16A-O | 50 | 40 | 27 | 300 | TN□□1604□□ |
| H50U-MTUNR/L16A-O | 63 | 50 | 35 | 350 | TN□□1604□□ |

EWLN · MWLN

95°

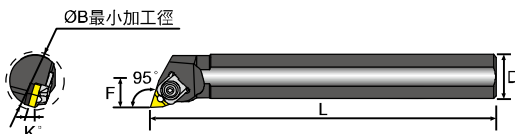
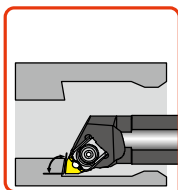

| 產品型號 Model No | 加工徑 ØB Min. Bore Dia. | 柄徑 D Shank Dia. | 刀尖距離 F Tip Distance | 全長 L O.A.L. | 刀片 Insert |
|------------------|--------------------------|--------------------|------------------------|----------------|------------|
| H20R-EWLNR/L06-O | 25 | 20 | 13 | 200 | WN□□0604□□ |
| H25R-EWLNR/L08-O | 32 | 25 | 17 | 200 | WN□□0804□□ |
| H25R-EWLNR/L08-O | 32 | 25 | 17 | 200 | WN□□0804□□ |
| H25T-EWLNR/L08-O | 32 | 25 | 17 | 300 | WN□□0804□□ |
| H32S-EWLNR/L08-O | 40 | 32 | 22 | 250 | WN□□0804□□ |
| H32U-EWLNR/L08-O | 40 | 32 | 22 | 350 | WN□□0804□□ |
| H20R-MWLNR/L08-O | 25 | 20 | 13 | 200 | WN□□0804□□ |
| H25R-MWLNR/L08-O | 32 | 25 | 17 | 200 | WN□□0804□□ |
| H32S-MWLNR/L08-O | 40 | 32 | 22 | 250 | WN□□0804□□ |

11



CN



TN



WN

EAX中心出水型平面銑刀盤 EAX High Speed Milling Cutter

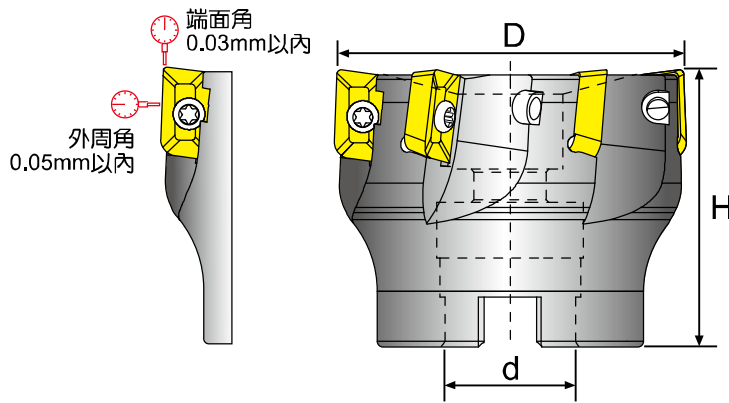

刀片安裝後其精度保證
端面刃在0.03mm以內
外周刃在0.05mm以內

Tolerance after install
insert face within 0.03mm,
peripheral within 0.05mm.

標準型 Standardtype

| 產品型號 Model No | D | H | d | INO | 刀片 Insert |
|---------------|-----|----|-------|-----|------------|
| EAX2040RB-O | 40 | 40 | 16 | 6 | AX□□1235□□ |
| EAX2050RB-O | 50 | 40 | 22 | 7 | AX□□1235□□ |
| EAX2063RB-O | 63 | 40 | 22 | 8 | AX□□1235□□ |
| EAX3040RB-O | 40 | 40 | 16 | 4 | AX□□1705□□ |
| EAX3050RB-O | 50 | 40 | 22 | 5 | AX□□1705□□ |
| EAX3063RB-O | 63 | 40 | 22 | 6 | AX□□1705□□ |
| EAX3080RA-O | 80 | 50 | 25.4 | 4 | AX□□1705□□ |
| EAX3100RA-O | 100 | 63 | 31.75 | 5 | AX□□1705□□ |
| EAX3125RA-O | 125 | 63 | 38.1 | 6 | AX□□1705□□ |

益詮牌泛用型中心出水平面銑刀盤

ECHAINTOOL brand universal type center coolant surface milling cutter

- ◆ 有效降低刃口溫度、提升排屑效能
Effectively reduce cutting edge temperature, improve chip removal evacuation efficiency.
- ◆ 延長刀盤及刀片使用壽命
Extend the life of the cutter head and insert.



多刃型 Multi-Blade

| 產品型號 Model No | D | H | d | INO | 刀片 Insert |
|---------------|-----|----|-------|-----|------------|
| EAXF3080RA-O | 80 | 50 | 25.4 | 7 | AX□□1705□□ |
| EAXF3080RB-O | 80 | 50 | 27 | 7 | AX□□1705□□ |
| EAXF3100RA-O | 100 | 63 | 31.75 | 8 | AX□□1705□□ |
| EAXF3100RB-O | 100 | 63 | 32 | 8 | AX□□1705□□ |
| EAXF3125RA-O | 100 | 63 | 38.1 | 9 | AX□□1705□□ |