



Suspension Clamps For LV-ABC Cable

Model:SL95

SL95 suspension clamp (angle clamp) is used to hang LV-ABC cables on poles with the insulated neutral messenger. Cutting section is universal, and insulated line is fixed by nut. The part connecting the wire is made of dielectric material. Welcome to buy Suspension Clamps For LV-ABC Cable from us. Every request from customers is being replied within 24 hours.

Product Introduction

Suspension Clamps For LV-ABC Cable

SL95 suspension clamp (angle clamp) is used to hang LV-ABC cables on poles with the insulated neutral messenger. Cutting section is universal, and insulated line is fixed by nut. The part connecting the wire is made of dielectric material.

Hanging the self-supporting insulated wire on the bracket with maximum angle of 90 degrees.

- **Cable Size:** 16-95mm²
- Made of of high mechanical strength and corrosion resistant aluminium alloy, the insulation cover is made of weather resistant material. Suitable for all climatic conditions.
- Binding bolt equipped with wing nut allows tool free installation
- **Standard:** EN 50483-3, NFC 33-040

The clamp consists of plastic insert, which clamp the optical cable without damaging. A wide range of gripping capacities and mechanical resistance archived by wide product range, with different sizes of neoprene inserts.

The metal hook of suspension clamp allows installation on the pole by using stainless steel band and pigtail hook or brackets. The hook of ADSS clamp can be produced form stainless steel materials according to you request.

These Suspension Clamps are suitable for a wide range of ABC cables; These are quickly and easily installed with absolutely no tool required for the installation process; It lines the angles up to 30 degrees to 60 degree.

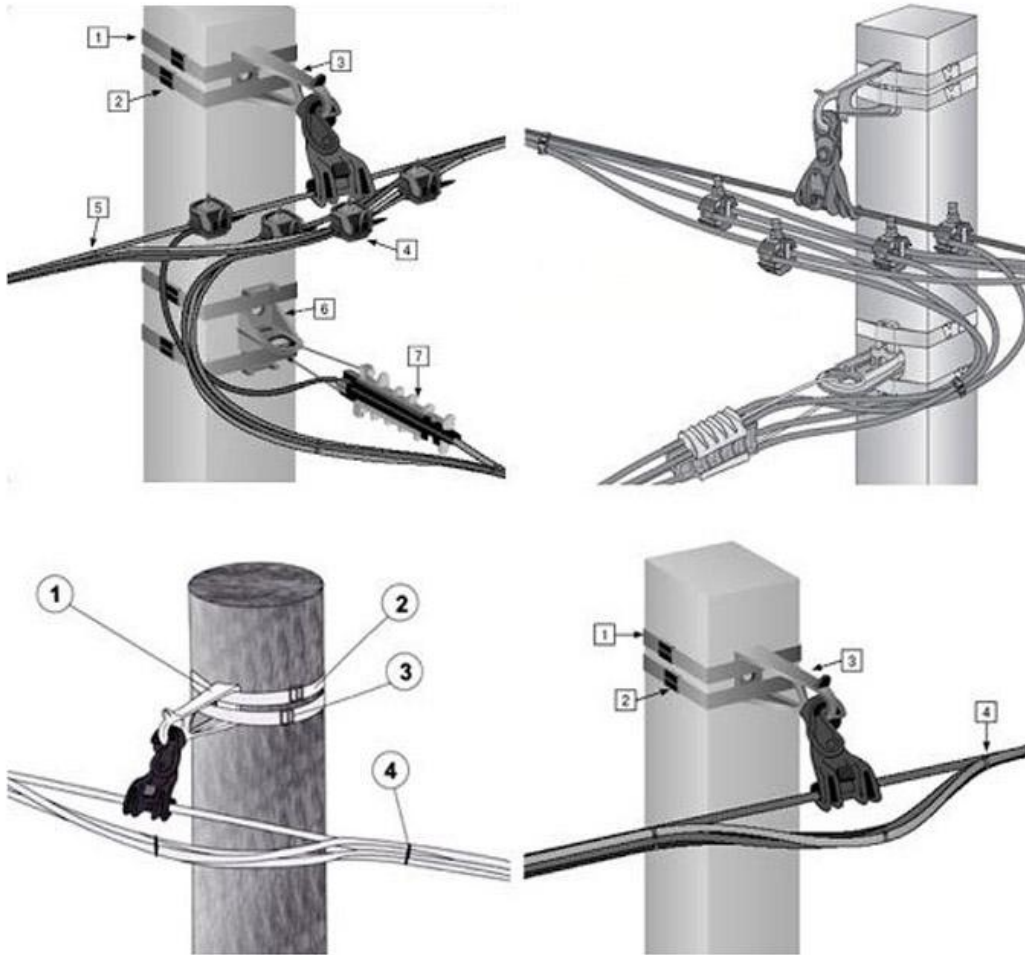



Standard use/Application



To support and suspend the line



To provide service connection by tapping main line.

Application Angle :

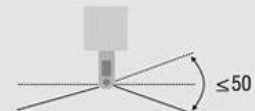
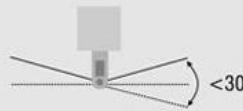

TECHNICAL DATA:

Model	SL95
Cable Size (mm ²)	16-95
Material of Body	Galvanized steel covered plastic

FAQ:

Q1: Are you a trading company or factory?

A2: We are the factory, and we are the supplier of 35% company in this field.

Q2: Are you able to customize the product for me?

A2: Yes, we owns the professional R&D team and complete Injection molding machine.

Q3: What is the acceptable payment term?

A3: Credit Card, West Union, Paypal or T/T.

Q4: What is the package could be?

A4: We can make special design as your requirement.

Q5: What is your day capacity?

A5: 10000-20000pcs