

MBR1035 THRU MBR10200

10.0 A Schottky Barrier Rectifier

VOLTAGE RANGE

35 to 200 Volts

CURRENT

10.0 Ampere

FEATURES

- * Low forward voltage drop
- * High current capability
- * High reliability
- * Low Power Loss, High Efficiency

MECHANICAL DATA

- * Case: Molded plastic
- * Epoxy: UL 94V-0 rate flame retardant
- * Lead: Axial leads, solderable per MIL-STD-202, method 208 guaranteed
- * Polarity: Color band denotes cathode end
- * Mounting position: Any
- * Weight: 1.98 grams

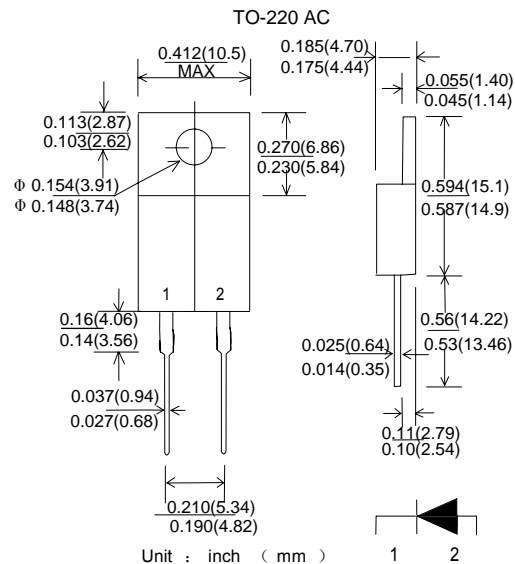

Maximum Ratings and Electrical Characteristics

- * Rating at 25 °C ambient temperature unless otherwise specified.
- * Single phase, half wave, 60 Hz, resistive or inductive load.
- * For capacitive load, derate current by 20%

Type Number	Symbol	MBR 1035	MBR 1045	MBR 1050	MBR 1060	MBR 1090	MBR 10100	MBR 10150	MBR 10200	Unit
Maximum Repetitive Peak Reverse Voltage	VRRM	35	45	50	60	90	100	150	200	V
Maximum RMS Voltage	VRMS	24	31	35	42	63	70	105	140	V
Maximum DC Blocking Voltage	VDC	35	45	50	60	90	100	150	200	V
Maximum Average Forward Rectified Current	IF	10								A
Peak Forward Surge Current, 8.3 ms Single Half Sine-wave Superimposed on Rated Load (JEDEC method)	IFSM	120								A
Maximum Instantaneous Forward Voltage @10A	VF	0.7		0.8		0.85		1.05		v
Maximum Reverse Current @ Rated VR TA=25 °C TA=125 °C	IR	300 1500								uA
Typical Junction Capacitance (Note 1)	Cj	150								pF
Typical Thermal Resistance(Note 2)	RθJA	30								°C/w
Operating and Storage Temperature Range	TJ	-65--+150								°C

NOTE1. Measured at 1.0 MHz and applied reverse voltage of 4.0V D.C.

NOTE2. Leads maintained at ambient temperature at a distance of 9.5mm from the case

RATINGS AND CHARACTERISTIC CURVES (MBR1035 THRU MBR10200)

