

KBPC610 SERIES

**SINGLE PHASE 6.0 AMPS.
SILICON BRIDGE RECTIFIERS**

**Voltage Range
50 to 1000 VOLTS
Current
6.0 Amperes**

Features

- UL Recognized File # E-230084
- High surge current capability
- Low forward voltage drop
- High temperature soldering guaranteed:
250°C/10 seconds/.375", (9.5mm)
- lead lengths at 5 lbs., (2.3kg) tension
- Small size, simple installation
- Leads solderable per MIL-STD-202,
Method 208

KBPC6

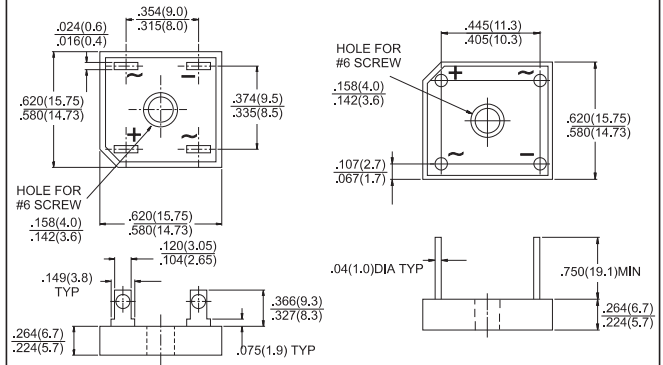

Dimensions in inches and (millimeters)

MAXIMUM RATINGS AND ELECTRICAL CHARACTERISTICS

Rating at 25°C ambient temperature unless otherwise specified.
Single phase, half wave, 60Hz, resistive or inductive load.
For capacitive load, derate current by 20%

Type Number		KBPC6005	KBPC601	KBPC602	KBPC604	KBPC606	KBPC608	KBPC610	UNITS
Maximum Repetitive Peak Reverse Voltage	V _{RRM}	50	100	200	400	600	800	1000	V
Maximum RMS Voltage	V _{RMS}	35	70	140	280	420	560	700	V
Maximum DC Blocking Voltage	V _{DC}	50	100	200	400	600	800	1000	V
Maximum Average Forward Rectified Current @T _A = 50°C	I _{F(AV)}	6.0							A
Peak Forward Surge Current, 8.3 ms Single Half Sine-wave Superimposed on Rated Load (JEDEC method)	I _{FSM}	200							A
Maximum Instantaneous Forward Voltage Drop Per Leg @6.0A	V _F	1.0							V
Maximum DC Reverse Current @ T _A = 25°C at Rated DC Blocking Voltage @ T _A = 100°C	I _R	10 55							uA uA
Operating Temperature Range	T _J	-55 to +125							°C
Storage Temperature Range	T _{STG}	-55 to +150							°C

RATING AND CHARACTERISTIC CURVES KBPC610 SERIES

FIG.1- MAXIMUM NON-REPEETITIVE FORWARD SURGE CURRENT PER BRIDGE ELEMENT

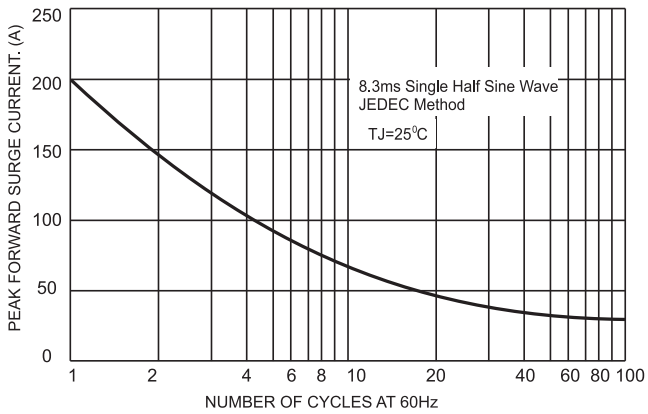

FIG.2- MAXIMUM FORWARD CURRENT DERATING CURVE

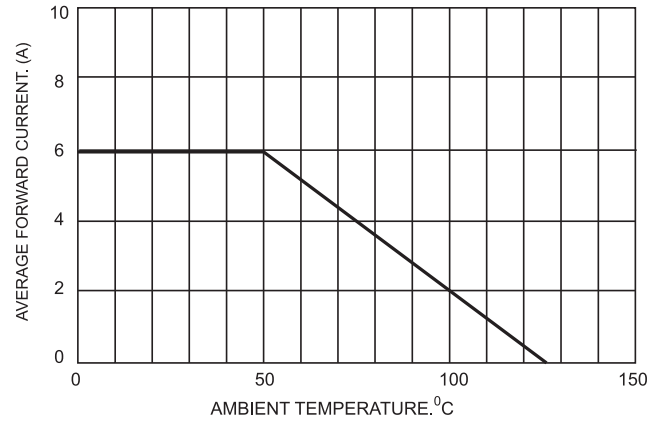

FIG.3- TYPICAL INSTANTANEOUS FORWARD CHARACTERISTICS PER BRIDGE ELEMENT

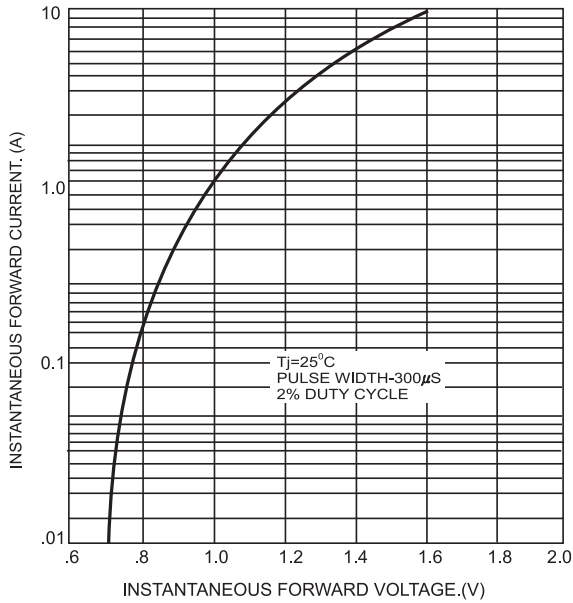

FIG.4- TYPICAL REVERSE CHARACTERISTICS PER BRIDGE ELEMENT

