

8KP17A/CA thru 8KP250A/CA Series 8000W Axial Leded Transient Voltage Suppressors

Features

- Peak power dissipation 8000W @10 x 1000 us Pulse
- Low profile package.
- Excellent clamping capability.
- Glass passivated junction.
- Fast response time: typically less than 1ps from 0 Volts to BV min
- Typical I_R less than 5uA when V_{BR} min above 24V.
- IEC 61000-4-2 ESD 30KV(Air), 30KV(Contact)
- ESD protection of data lines in accordance with IEC 61000-4-2
- EFT protection of data lines in accordance with IEC 61000-4-4
- Halogen free and RoHS compliant
- Lead-free finish

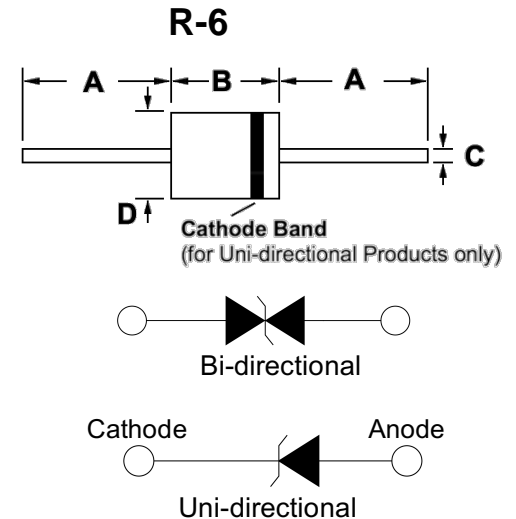

Mechanical Characteristics

- CASE: R-6 Molded Plastic
- Mounting Position: Any
- Polarity: by cathode band denotes uni-directional device, none cathode band denotes bi-directional device.
- Terminal: Solder plated

REF.	DIMENSIONS			
	Millimeters		Inches	
	Min.	Max.	Min.	Max.
A	25.4	---	1.000	---
B	8.6	9.5	0.34	0.375
C	1.2	1.3	0.048	0.052
D	8.6	9.5	0.340	0.375

Maximum Ratings and Characteristics @ 25°C Ambient Temperature (unless otherwise noted)

Parameter	Symbol	Value	Units
Peak Pulse Power Dissipation on 10/1000 us Waveform (Note 1, FIG.1)	P_{PPM}	Min 8000	W
Power Dissipation on Infinite Heat Sink at $T_L=75^\circ\text{C}$	P_D	8.0	W
Peak Pulse Current of on 10/1000us Waveform (Note 1, FIG.3)	I_{PPM}	See Table 1	A
Peak Forward Surge Current, 8.3ms Single Half Sine-Wave (Note 2)	I_{FSM}	400	A
Operating Junction Temperature Range	T_J	-55 to 150	$^\circ\text{C}$
Storage Temperature Range	T_{STG}	-55 to 150	$^\circ\text{C}$

Notes:

1. Non-repetitive current pulse, per Fig.3 and derated above $T_A=25^\circ\text{C}$ per Fig.2.
2. Measured on 8.3ms single half sine-wave, or equivalent square wave, for Unidirectional device only.

8KP Series Electrical Specification

Part Number		Reverse Stand-Off Voltage	Breakdown Voltage Min. @IT	Breakdown Voltage Max. @ IT	Test Current	Maximum Clamping Voltage @IPP	Peak Pulse Current	Reverse Leakage @VRMW
Uni	Bi	VRMW(V)	VBR MIN(V)	VBR MAX(V)	IT (mA)	VC(V)	IPP(A)	IR(uA)
8KP17A	8KP17CA	17.0	18.90	20.90	5	27.6	293.5	150
8KP18A	8KP18CA	18.0	20.00	22.10	5	29.2	277.4	100
8KP20A	8KP20CA	20.0	22.20	24.50	5	32.4	250.0	50
8KP22A	8KP22CA	22.0	24.40	26.90	5	35.5	228.2	15
8KP24A	8KP24CA	24.0	26.70	29.50	5	38.9	208.2	5
8KP26A	8KP26CA	26.0	28.90	31.90	5	42.1	192.4	5
8KP28A	8KP28CA	28.0	31.10	34.40	5	45.4	178.4	5
8KP30A	8KP30CA	30.0	33.30	36.80	5	48.4	167.4	5
8KP33A	8KP33CA	33.0	36.70	40.60	5	53.3	152.0	5
8KP36A	8KP36CA	36.0	40.00	44.20	5	58.1	139.4	5
8KP40A	8KP40CA	40.0	44.40	49.10	5	64.5	125.6	5
8KP43A	8KP43CA	43.0	47.80	52.80	5	69.4	116.7	5
8KP45A	8KP45CA	45.0	50.00	55.30	5	72.7	111.4	5
8KP48A	8KP48CA	48.0	53.30	58.90	5	77.4	104.7	5
8KP51A	8KP51CA	51.0	56.70	62.70	5	82.4	98.3	5
8KP54A	8KP54CA	54.0	60.00	66.30	5	87.1	93.0	5
8KP58A	8KP58CA	58.0	64.40	71.20	5	93.6	86.5	5
8KP60A	8KP60CA	60.0	66.70	73.70	5	96.8	83.7	5
8KP64A	8KP64CA	64.0	71.10	78.60	5	103.0	78.6	5
8KP70A	8KP70CA	70.0	77.80	86.00	5	113.0	71.7	5
8KP75A	8KP75CA	75.0	83.30	92.10	5	121.0	66.9	5
8KP78A	8KP78CA	78.0	86.70	95.80	5	126.0	64.3	5
8KP85A	8KP85CA	85.0	94.40	104.00	5	137.0	59.1	5
8KP90A	8KP90CA	90.0	100.00	111.00	5	146.0	55.5	5
8KP100A	8KP100CA	100.0	111.00	123.00	5	162.0	50.0	5
8KP110A	8KP110CA	110.0	122.00	135.00	5	177.0	45.8	5
8KP120A	8KP120CA	120.0	133.00	147.00	5	193.0	42.0	5
8KP130A	8KP130CA	130.0	144.00	159.00	5	209.0	38.8	5
8KP150A	8KP150CA	150.0	167.00	185.00	5	243.0	33.3	5
8KP160A	8KP160CA	160.0	178.00	197.00	5	259.0	31.3	5
8KP170A	8KP170CA	170.0	189.00	209.00	5	275.0	29.5	5
8KP180A	8KP180CA	180.0	200.00	221.00	5	289.0	28.0	5
8KP190A	8KP190CA	190.0	211.00	233.00	5	310.0	26.1	5
8KP200A	8KP200CA	200.0	222.00	246.00	5	329.2	24.6	5
8KP210A	8KP210CA	210.0	233.00	258.00	5	349.5	23.2	5
8KP220A	8KP220CA	220.0	244.00	270.00	5	371.1	21.8	5
8KP250A	8KP250CA	250.0	277.00	306.00	5	425.0	19.1	5

※ For Bi-directional type having V_{RWM} of 20 Volts and less, the I_R limit is double.

※ For parts without A, the V_{BR} is $\pm 10\%$ and V_C is 5% higher than with A parts.

8KP17A/CA thru 8KP250A/CA Series

I-V Curve Characteristics

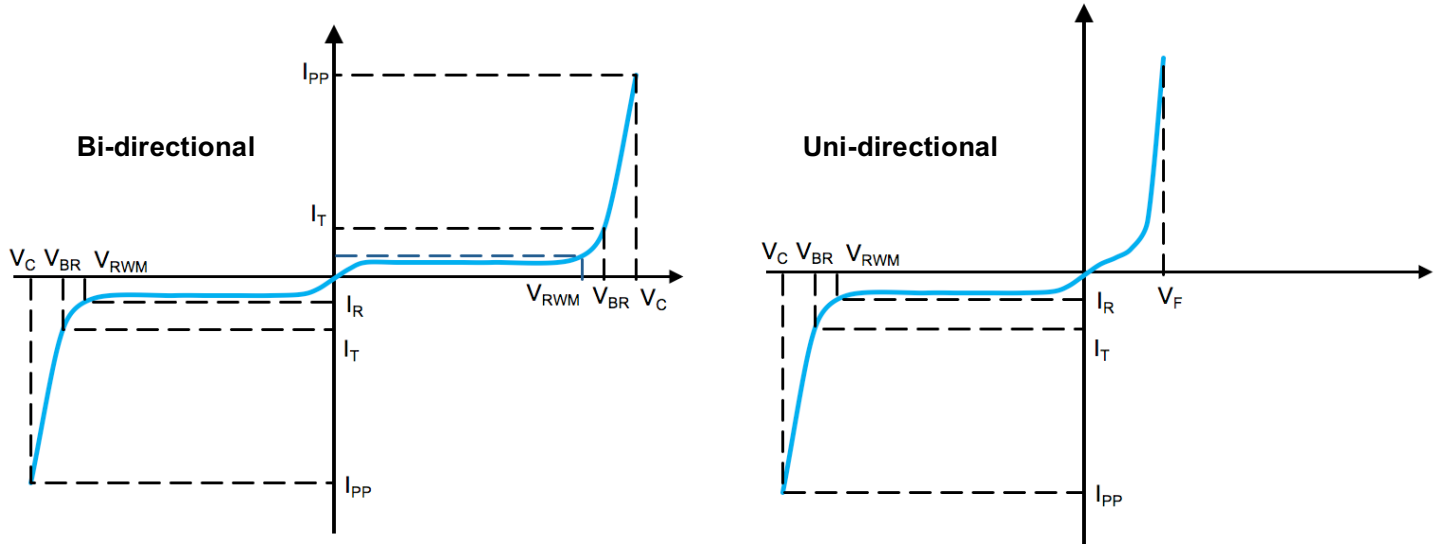

- P_{PPM}** Peak Pulse Power Dissipation - Max power dissipation
- V_{RWM}** Reverse Stand-off Voltage - Maximum voltage that can be applied to TVS without operation
- V_{BR}** Breakdown Voltage – Maximum voltage that flows through the TVS at a specified current (I_T)
- V_C** Clamping Voltage – Peak voltage measured across the TVS at a specified I_{PPM} (peak impulse current)
- I_R** Reverse Leakage Current – Current measured at V_R
- V_F** Forward Voltage Drop for Uni-directional

Ratings and Characteristic Curves ($T_A=25^\circ\text{C}$ unless otherwise noted)

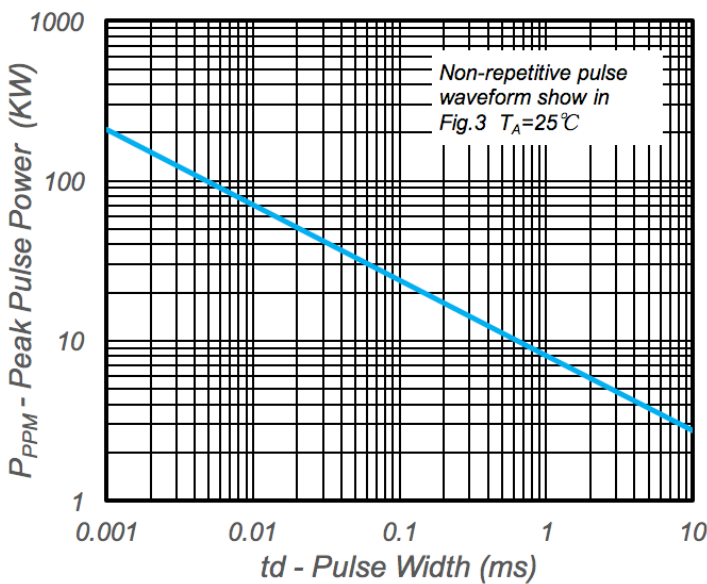

Fig.1 - Peak Pulse Power Rating

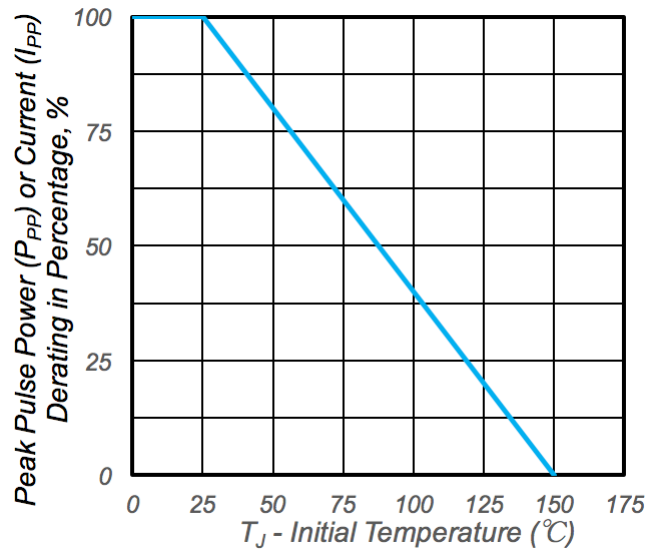

Fig.2 - Pulse Derating Curve

8KP17A/CA thru 8KP250A/CA Series

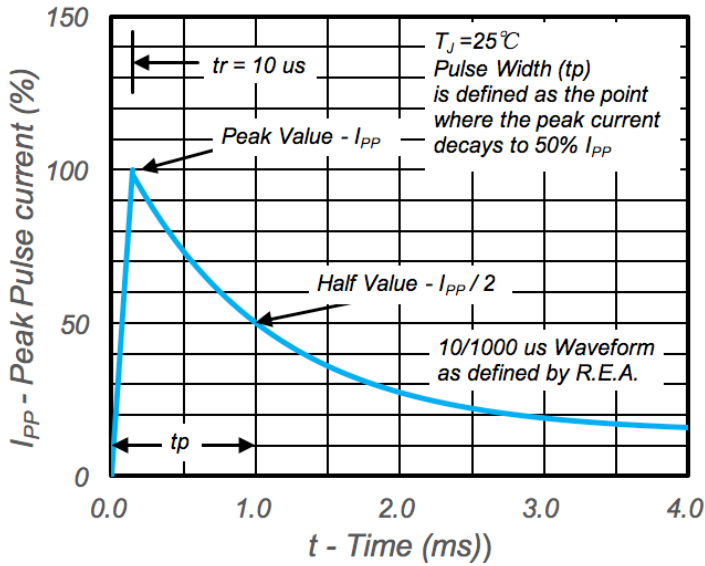

Fig.3 – Pulse Waveform

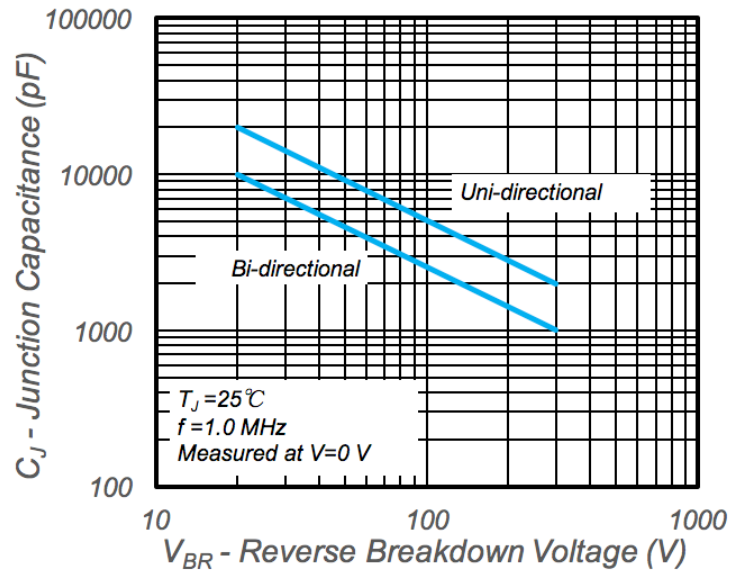

Fig.4 - Typical Junction Capacitance