



## Plastic Mixing Storage Tank

AMX-L Series Euro Storage Plastic Color Mixer Tank is mainly used for mixing plastic material and masterbatch pellets and powders. The storage color mixer is not only a mixing machine, but also a storage tank. The Plastic Mixing Storage Tank machine equipped with suction pipe for connecting with vacuum hopper loader for conveying materials into hopper dryer and injection molding machine. The color

mixer also equipped with small size gear motor with low power consumption for energy-saving.

## Plastic Mixing Storage Tank

### 1. Plastic Mixing Storage Tank Introduction

AMX-L Series Euro Storage Plastic Color Mixer Tank is mainly used for mixing plastic material and masterbatch pellets and powders. The storage color mixer is not only a mixing machine, but also a storage tank. The machine equipped with suction pipe for connecting with vacuum hopper loader for conveying materials into hopper dryer and injection molding machine. The color mixer also equipped with small size gear motor with low power consumption for energy-saving.

### 2. Plastic Mixing Storage Tank Parameter (Specifications)

Model & Specifications		AMX-80L	AMX-160L	AMX-260L
Power	Kw	0.37	0.55	1.1
Mixing Barrel Volume	Liters	80	160	260
Mixing capacity	Kg	50	100	150
Rotor Running Speed	RPM	210	210	210
Weight	Kg	60	100	150
L	mm	770	940	1000
W	mm	660	815	880
H	mm	1130	1320	1485

Please excuse for not note if some specifications of products are changed.

Ningbo Aumax Plastic Machinery Co., Ltd

Address: No. 216, Lianhe Rd., Ningbo Economic & Tech Development Zone, Beilun, Ningbo, China

Phone: +86-13819843291

Tel: +86-574-26850648

Fax: +86-574-26855258

E-mail: sales@aumax-plast.com

Note: The standard power supply is 3Ø 380V 50Hz. Other power supply is available.

### 3. Plastic Mixing Storage Tank Features & Application

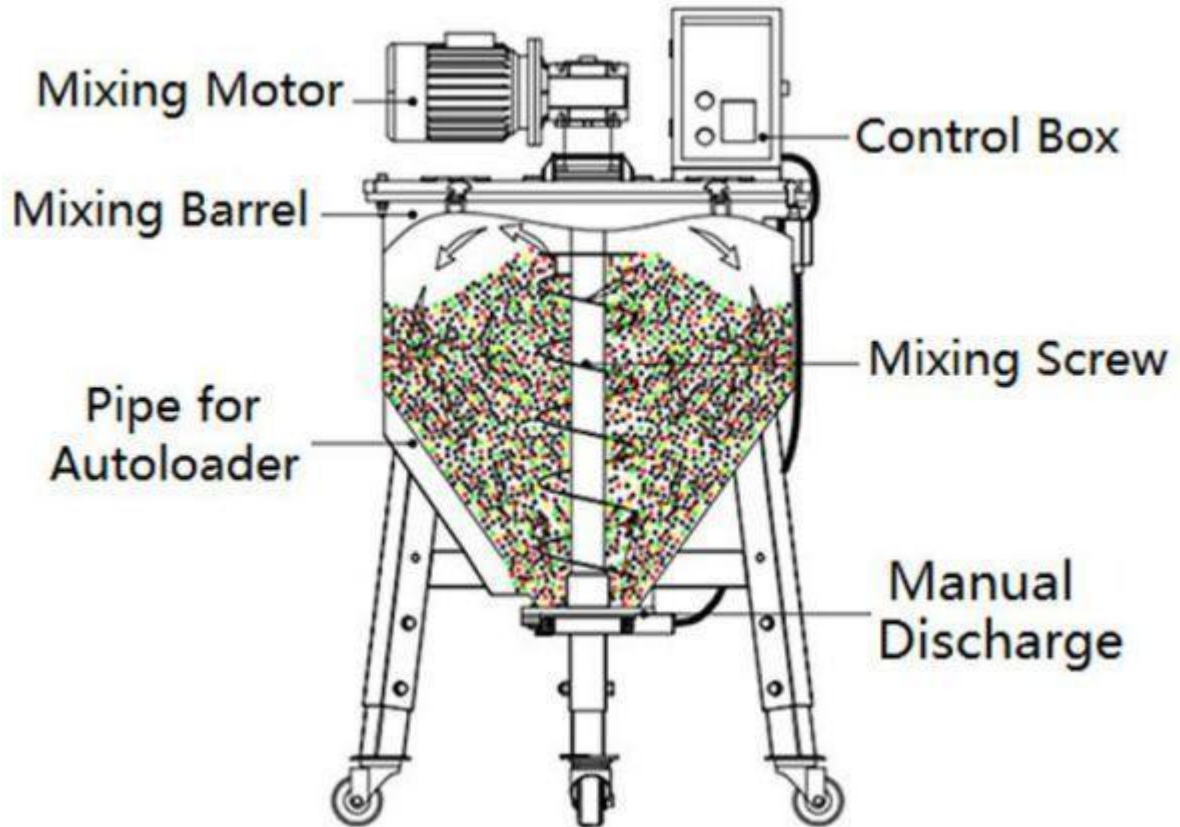

- 1) All machine parts which have to contact plastic materials, are made of stainless steel to prevent pollution to materials.
- 2) The plastic color mixer equipped with 24 hours timer to start and stop mixing automatically.
- 3) High efficiency gear motor to mix material in a short time for energy-saving.
- 4) Equipped with main power switch, safety interlocking switch and thermo-relay to keep people away from injury and avoid damage to machine.
- 5) With suction pipe for material feeding and manual discharge for easy cleaning.
- 6) With castors for easy installation and moving of the machine.

### 4. Plastic Mixing Storage Tank Qualification

Ningbo Aumax Plastic Machinery Co., Ltd

Address: No. 216, Lianhe Rd., Ningbo Economic & Tech Development Zone, Beilun, Ningbo, China

Phone: +86-13819843291

Tel: +86-574-26850648

Fax: +86-574-26855258

E-mail: sales@aumax-plast.com

Aumax Plast has been focusing on R&D and manufacturing of plastic recycling machine and auxiliary equipment for injection molding machine, blowing molding machine and plastic extrusion line for more than 15years.

We have obtained various domestic and foreign certifications such as ISO9001, ISO14001, CE, etc., which fully demonstrates that our products fully comply with international standards and the quality of products is guaranteed.



## 5. Delivery, Shipping and Serving

Normally, the delivery time of our plastic machines is 10-20 days after order confirmed and advance payment. All of Aumax plastic screw type plastic color mixer storage tank are packed in plywood cases. Usually, we ship large machines by LCL or FCL ocean shipping. Sometimes, customers need machine urgently, we ship machine by air or express.

Ningbo Aumax Plastic Machinery Co., Ltd

Address: No. 216, Lianhe Rd., Ningbo Economic & Tech Development Zone, Beilun, Ningbo, China

Phone: +86-13819843291

Tel: +86-574-26850648

Fax: +86-574-26855258

E-mail: sales@aumax-plast.com

**Packing:**



**Shipping:**



Sea Transportation



Air Transportation



Express

## 6. FAQ

**1. Q: What is the MOQ?**

A: The MOQ is 1 set for all products..

**2. Q: Where is the loading port?**

A: The nearest port to our factory is port of Ningbo, China, as well as we can send machine to Yiwu, Shanghai, Guangdong or any other cities in China.

**3. Q: What are the payment terms?**

A: The preferential payment term is T/T, while other payment terms are negotiable.

**4. Q: What are your terms of delivery?**

A: We accept FOB, CFR, CIF, EXW, and DDU. You can choose the terms which is the most convenient and cost effective to you.

**5. Q: How does your factory carry out quality control?**

Ningbo Aumax Plastic Machinery Co., Ltd

Address: No. 216, Lianhe Rd., Ningbo Economic & Tech Development Zone, Beilun, Ningbo, China

Phone: +86-13819843291

Tel: +86-574-26850648

Fax: +86-574-26855258

E-mail: sales@aumax-plast.com



[www.aumaxplast.com](http://www.aumaxplast.com)

A: Powerful R&D teams and professional QC department take care of every detail during design, processing, assembling, testing and packing.

**6. Q: Can you supply OEM and customized products?**

A: Yes, we can supply OEM / ODM service. Our engineers have rich experience in design and production of plastic auxiliary equipment. We can supply special products according to your ideas and drawings.

**7. Q: What about warranty terms?**

A: We provide one year warranty for all of our products. During warranty period, if any machine parts damaged due to quality, we will send the new parts by courier immediately by free of charge. Also, we supply 24 hours online service and technical support.

Ningbo Aumax Plastic Machinery Co., Ltd

Address: No. 216, Lianhe Rd., Ningbo Economic & Tech Development Zone, Beilun, Ningbo, China

Phone: +86-13819843291

Tel: +86-574-26850648

Fax: +86-574-26855258

E-mail: [sales@aumax-plast.com](mailto:sales@aumax-plast.com)