

# PD-PIR2600 LED Infrared Sensor Lights Instruction

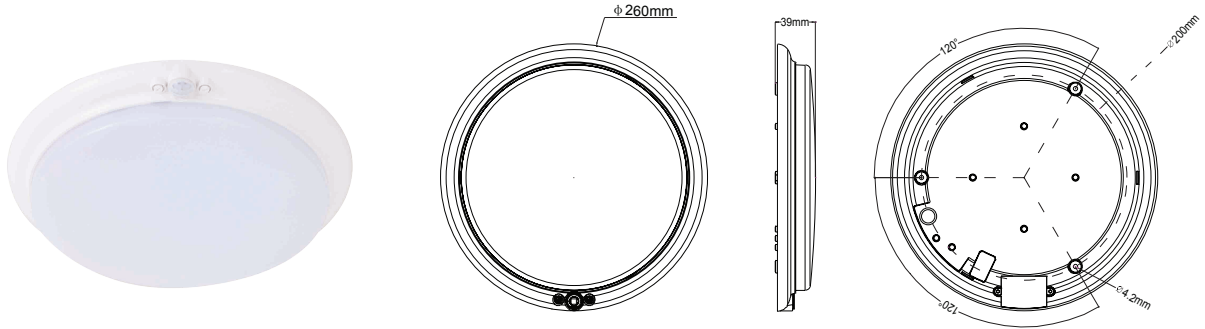

Packing list in	Quantity
LED infrared sensor light LEDS 86PCS	1X
$\phi 6$ Plastic expansion	3X
3x30 Screw	3X
3x6 Screw	1X
Line pressing cap	1X
B07 Operation tools	1X

## Summary

As a modern illuminant, LED has become a development trend in the lighting industry due to the characteristics of high efficiency, long life expectancy and relatively low energy consumption. How to use it reasonably and efficiency is the key issue in the lighting industry. PD-PIR2600 is an infrared sensor switches controlled LED lights, the infrared sensor was built into the light, it has 86pcs high brightness LEDs inside, with total power of 12 watts. The reasonable LED layout makes a homogeneous heat flow and achieves the most optimized luminous efficiency. The luminance is higher than 60W incandescent lamp when it works, and the life time is much longer than the common halogen lamp. When one enters the detection filed and trigger the sensor to work, the light turns on; when one leaves the detection filed and the setting time reaches, the light will turn off. It can detect the ambient light illumination automatically and set and adjust the value according to the fact

need. Such as, the light will turn on and works when the ambient light illumination is under setting value. once it exceeds the setting value, the light will stop working. The light will be on until the time-delay comes when the sensor is triggered. Once detected the constant signal, the time will be overlaid and the light will be on constantly. It can be installed in indoor, corridor and public-building. It's a very ideal substitute as an energy-saving illuminant.

## Specifications

Power source: 220-240VAC

Power frequency: 50Hz

Rated load: 12W Max.

Detection range(22°C): 7m Max(Wall installation)  
5-9m Max (dia.)(Ceiling installation)

Time setting: min: 12±3sec  
max: 5±1min(adjustable)

Light-control: 10-2000LUX(adjustable)

Luminous flux: 1100lm

Material: Boden:PC Lampshade:PC

Standby power: <0.7W

LED quanlity: 86PCS

LED specifications: T2835

Detection motion speed: 0.6~1.5m/s

Working temperature: -10°C ~ +40°C

Working humidity: <95%RH

Installation height: 1.5-3m (Ceiling installation)  
2.5-3.5m (Wall installation)

## The names of each part

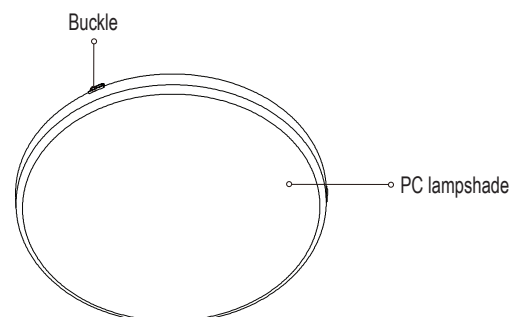
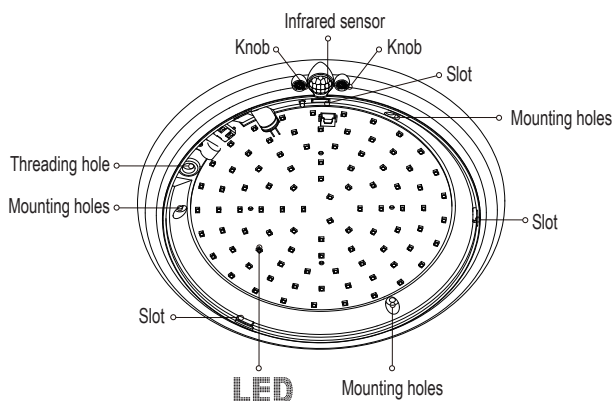

## Sensor information

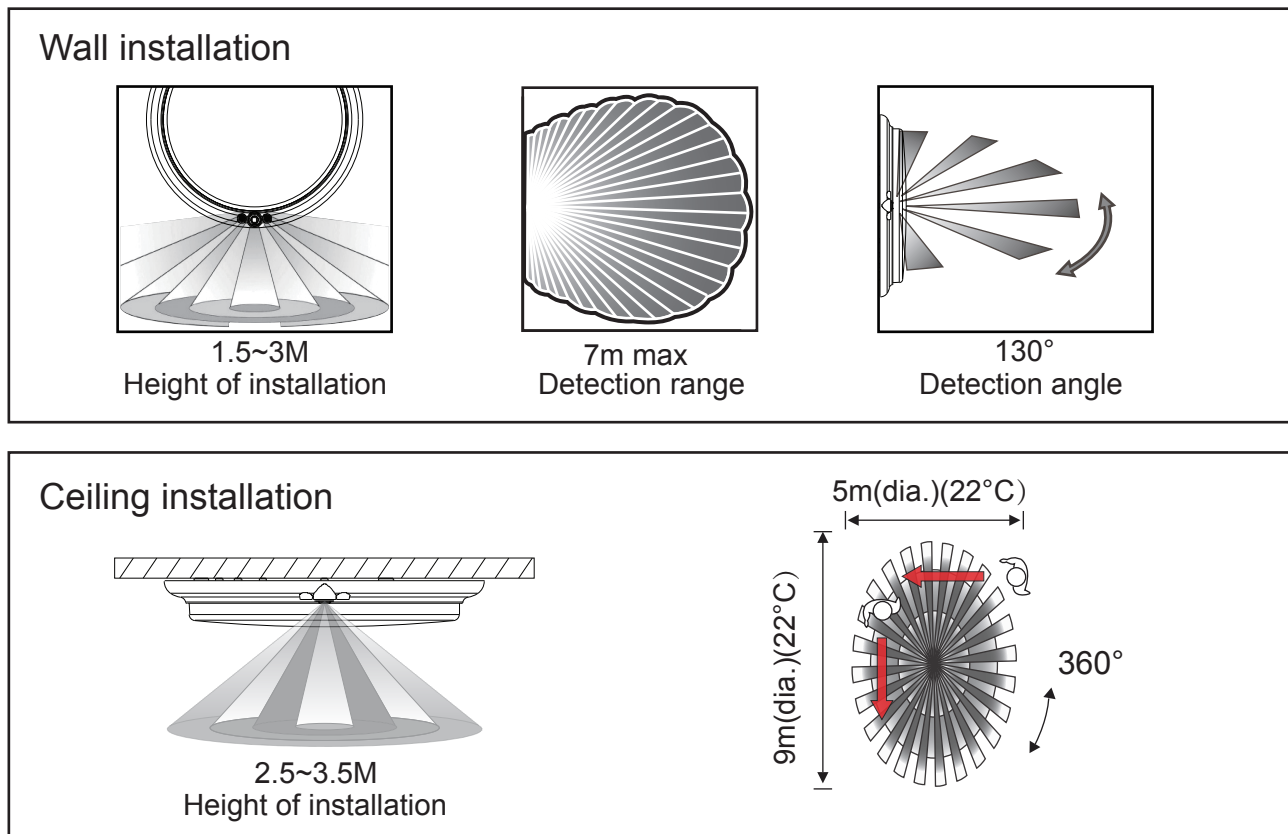

## Function

- Detection field: the detection field is made up of up and down, left and right service field, it can be selected according to the consumer's desire. But the moving orientation has great relationship with the sensitivity.
- Can identify day and night: the light control can be adjusted freely when it works. It can work in the daytime and at night when it is adjusted on the "sun" position (max); but it can only work in the light control less than 10lux when it is adjusted on the "moon" position (min). As for the adjustment pattern, please refer to the testing pattern.
- Time delay can be added continually: when it received the second induction signal after the first it will compute time once more on the rest of the first time delay basic.(Set time)
- Light-control potentiometer (LUX): clockwise the knob to increase its value; anti-clockwise the knob to decrease its value.
- Time potentiometer (TIME): clockwise the knob to increase its value, the maximum delay time is (5±1) minutes; anti-clockwise the knob to decrease its value, the minimum delay time is (12±3) seconds.

## Setting manner one:potentiometer

It may take times to adjust values before they satisfy your need.

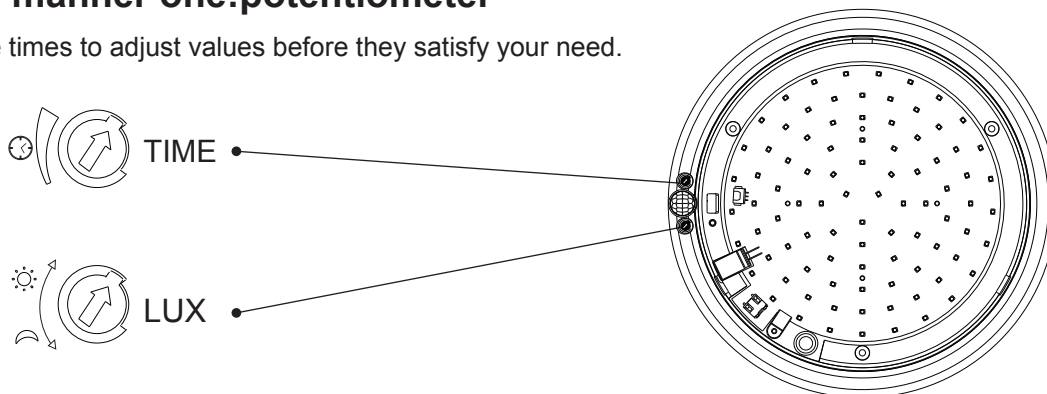

Fig.1

## (1)Time setting



It can be defined from 9 seconds(turn fully anti-clockwise) to 6minutes(turn fully clockwise). Any movement detected before this time elapses will re-start the timer. It is recommended to select the shortest time for adjusting the detection range and for performing the walk test.

**NOTE:**When the light be auto off,it will take 1 second before the sensor is ready to detect another movement,that is,only signal detected 1 seconds later can the light be auto-on.

It is mainly for the adjustment of the delay time from the moment the signal detected and light auto-on till the light auto-off. You can define the delay time to your practical need. But you'd better lower the delay time for the sake of energy saving, since the microwave sensor has the function of continuous sensing, that is, any movement detected before the delay time elapses will re-start the timer and the light will keep on only if there is human in the detection range.

## (2)Light-control setting



It can be defined in the range of 10~2000 LUX. To turn the knob fully anti-clockwise is about 10 lux,fully clockwise is about 2000 lux.When adjusting the detection zone and performing the walk test in daylight,you should turn the knob fully clockwise.

**Note:** please don't adjust the two functional knobs to excess. That is because the two functional knobs were connected to the components directly, there is a small stopper in each of the three components, when you adjust the knobs from start to end, the excessive turn will damage the stopper, and lead to the 360°non-stop turn around. The adjust range limit is 270°, please do pay attention to this.

## Procedure of installation

- Step1 Turn off the power.
- Step2 Before installing the lamp, use tools to pry open three bayonets in turn and remove the lampshade. (as Fig.2)
- Step3 Mark the hole position with a pencil after determining where you want to install the product.  
Note:If it is a wooden wall,there is no need to use plastic expansion screw,just fasten the screw with the screwdriver.
- Step4 Drill holes on the walls where there is pencil mark with an electric drill and get the plastic expansion inside the hole.
- Step5 Connect the cable to the lamp through the cable entry openings.wire size : 0.2-0.75mm<sup>2</sup>(as Fig.3)
- Step6 Use the screw to fix the lamp base on the place where has been chosen.(as Fig.4)
- Step7 Fasten the cover to the lamp base which has been installed on the wall and adjust the knob.(as Fig.5)
- Step8 Product can be used when the power is turned.

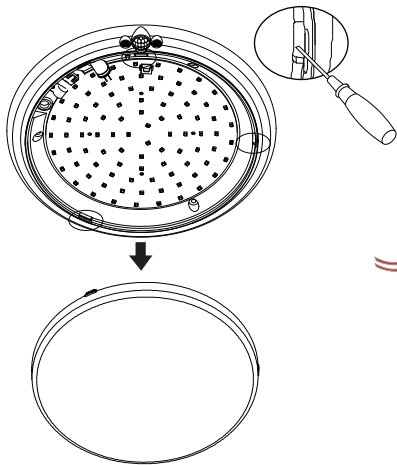

Fig.2

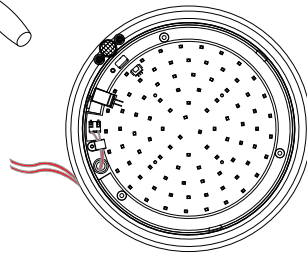

Fig.3

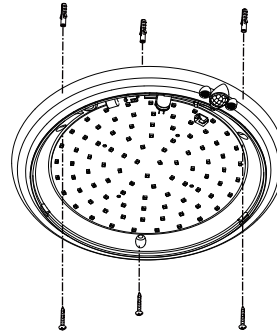

Fig.4

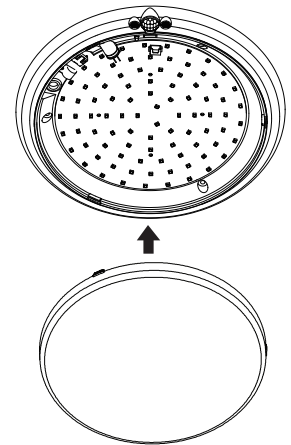

Fig.5

**Note: if the lamp needs to be removed or replaced, please use the B07 Operation tools and remove the power wire.(as Fig.6)**

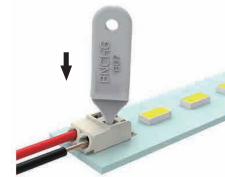

Fig.6



## Warning!

1. Please keep it away from the children when installation.
2. Please avoid to be installed where the temperature is high.
3. Please cut off the power before installation.

## Notes

- Electrician or experienced human can install it.
- The unrest objects can't be regarded the installation basis-face.
- In front of the detection window there should be no hinder or unrest objects effecting detection.
- Avoid installing it near air temperature alteration zones for example: air condition, central heating, etc.
- Please don't open the case for your safety if you find the hitch after installation.

## Remark

1. Keep the sensor face to the area where human usually move.
2. Keep the sensor face to the position of the ambient light in order to get much more exact illuminance setting.
3. If detect the signal again within the time-delay, the time-delay will be over lied.
4. LUX knob: the luminance of working conditions . When the knob switches ☀️, it means it can detect all day, when the knob switches 🌙, it will only work below the luminance <10 LUX.
5. TIME knob: It is a period that the light turns on slowly to no any signal gradually, till out of work.



## Warning!

- Please confirm with professional installation.
- Please cut off power supply before installation and removal operations.
- Make sure that you have cut off the power for safety purposes.
- Improper operation caused losses, the manufacturer does not undertake any responsibility.

**This manual is for the current content programming of this product, there are any changes and modifications to the manufacturer without notice!**

**This instruction, without our permission, should not be copied for any other purposes.**