

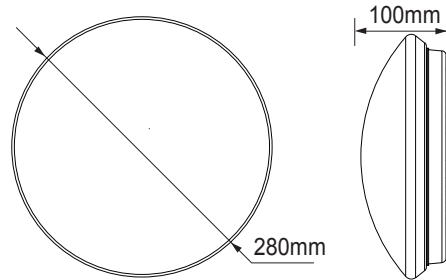

PD-LED2037-D Microwave Sensor Lamp Instruction



Summary

Packing list in	Quantity
Microwave Sensor Lamp	1X
 φ6 Plastic Expansion	3X
 3x30 Screw	3X
Instruction	1X

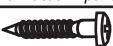
This is a newly designed intelligent ceiling mount Microwave sensor LED lamp, with the extra function of power supply in emergency. The lighting is auto-managed by AC direct power or battery backup, that is, when power failure, the battery backup will be responsible for the power supply of 3.5 watt. When light on, the luminous flux will be more than 330 lm, equivalent to that of 60 watt incandescent lamp(≈400lm).The battery backup can continuously supply power for more than 2 hours or even more in the sensor energy-saving mode. It is widely applied in the corridor, washing room, elevator lobby etc.

This product is designed with two configurations: one is the sensor lamp with the function of supplying power in emergency and the other one is the intelligent sensor lamp without the emergency function. You can make purchase according to the practical need. But in most cases, it is necessary and wise to choose the former one, for that the occasional power outage will cause trouble, or even danger.



Use high quality White frosted glass chimney.Strengthen the flexible refraction of light.And its function of anti-ultraviolet makes the shade not easy to turn yellow and be broken.

Name of each part

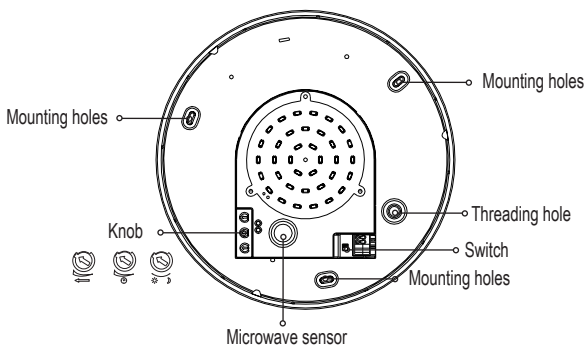

Lamps and lanterns base

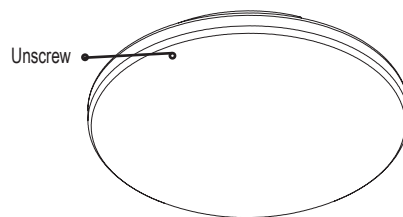

White frosted glass chimney

Specifications

Power source: 100-240V/AC 50/60Hz
 Rated LED: 9W Max.(AC)
 3.5W Max.(DC)
 Charging Power:7W Max.(light off)
 3W Max.(light on)
 Protection:IP20,Class2
 Material: Body:PC Lampshade:Glass
 HF system: 5.8GHz
 Battery: 7.4V / 2000mAH lithium battery
 Continuous illumination time: ≥180min
 (when the battery power supply)

Transmission power: <0.2mW
 Time setting: 8sec to 30min (adjustable)
 Detection range: 1-8m (radii.) (adjustable)
 Light-control: 10-2000LUX(adjustable)
 Detection angle: 360°
 Luminous flux: 340lm (AC) 330lm (DC) (warm white)
 570lm (AC) 490lm (DC) (cold white)
 Installation height: 2.5-3.5m (ceiling mount)
 Working Temperature:-20~+55 °C
 LED quantity: 36PCS
 LED specifications: FM-2835WNS

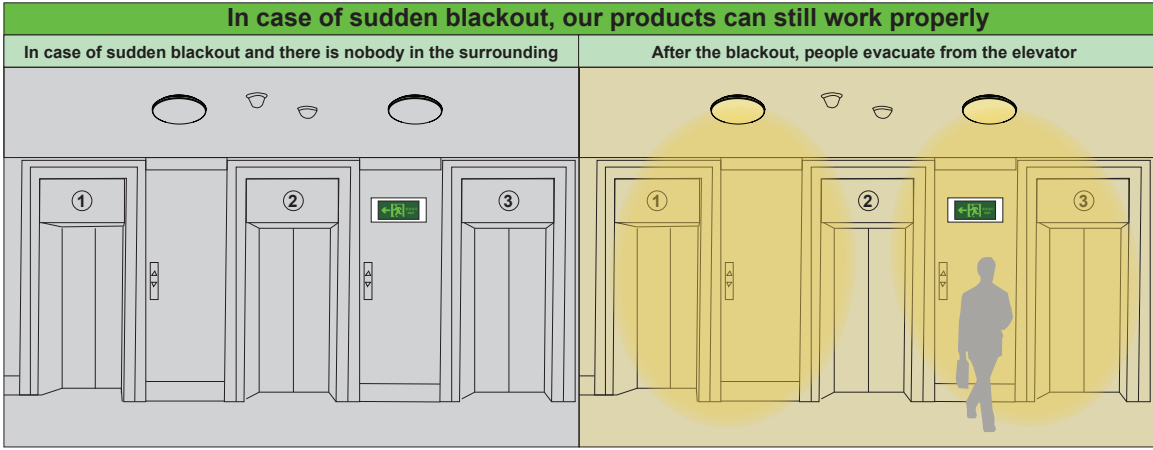

* Installed in the elevator, when power fails, it still supports lighting for the trapped.

Sensor information

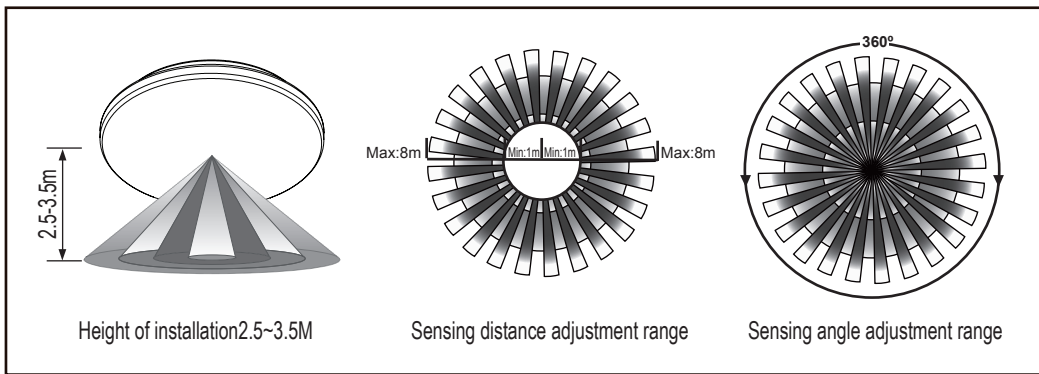

Spectrogram

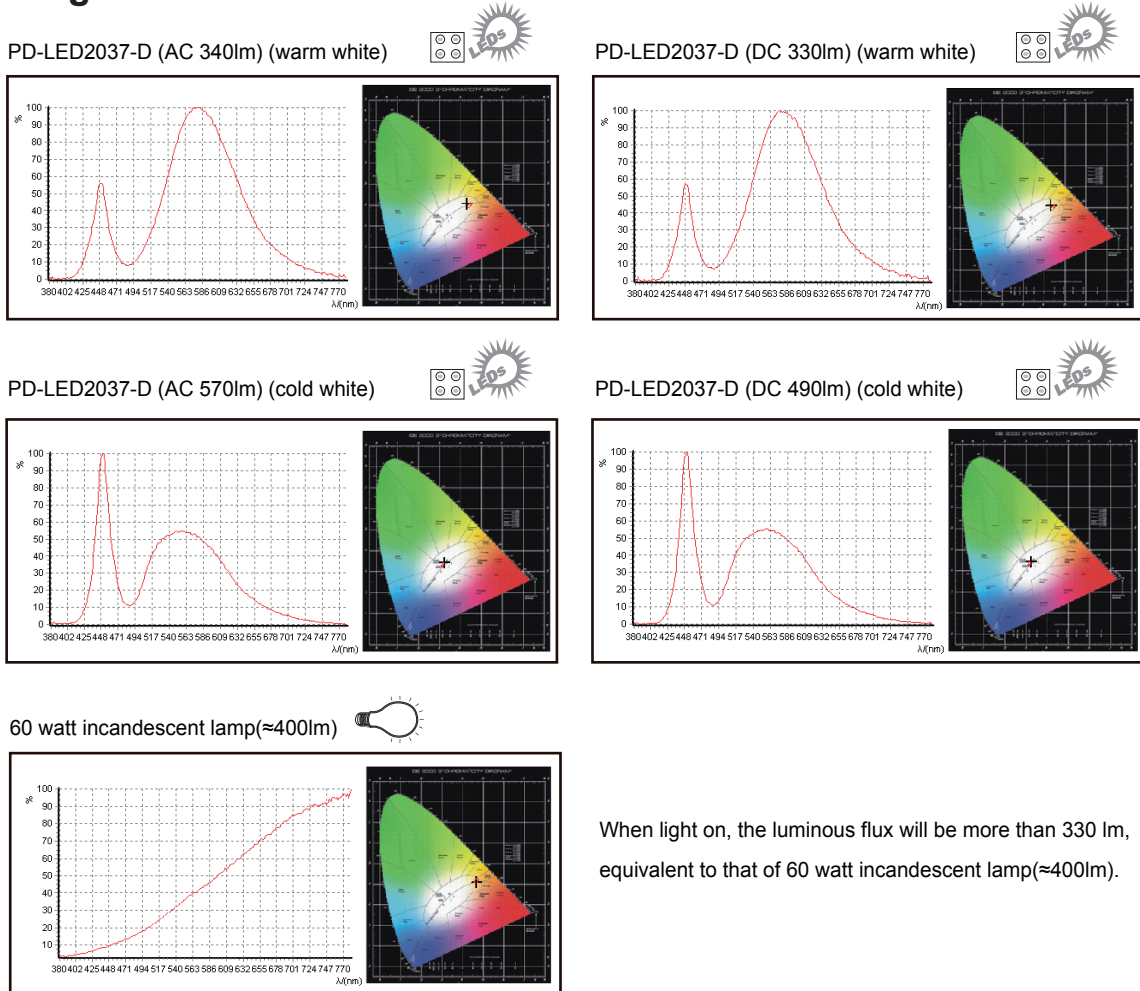

Function

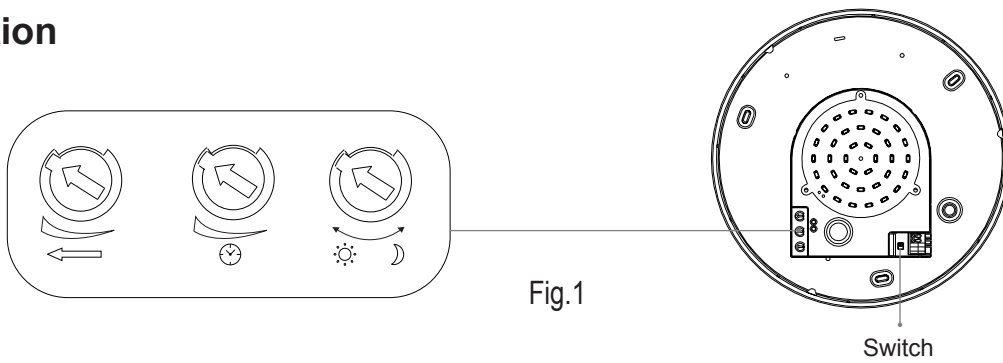

Switch

This switch is to control the battery connection. To avoid power-consumption in transit or in storage, we preset the switch to OFF, that is, the battery is not connected. Before installation, you should set the switch to ON to make sure that the battery is well connected to achieve the power-supply in emergency. This LED lamp with emergency function can be used as the common lamp, but when power failure, it will support lighting with battery automatically.

Detection range setting (sensitivity)



Detection range is the term used to describe the radii of the more or less circular detection zone produced on the ground after mounting the sensor light at a height of 2.5m, turn the detection range control fully anti-clockwise to select minimum detection range(approx. 1m radii), and fully clockwise to select maximum detection range(approx. 8m radii).

NOTE: the above detection range is gained in the case of a person who is between 1.6m~1.7m tall with middle figure and moves at a speed of 1.0~1.5m/sec. if person's stature, figure and moving speed change, the detection range will also change.

In different cases, the sensitivity of the lights has certain deviation.

The detection distance may multiply for the reflection on microwave electromagnetic field by the metal or glass materials. Thus, lower the sensitivity to reach the appropriate detection distance. Never turn the SENS knob to the maximum value to avoid error detection. Also the surrounding environment will lead to error action, e.g. the automobiles passing by or the wandering objects caused by the wind. Products should be installed more than 4 meters one from the other, otherwise the interference among them will cause error action.

The proper use of sensitivity potentiometer: as the photograph show, the knob is specialized in adjusting sensitivity.when use,user can adjust the knob to the middle. Of course, in the process of the practical usage,if you feel the sensitivity is ok ,you don't need to adjust it. If you feel it is low,you could adjust it higher properly. Due to some environment led to wrong action,such as car passing,wind making object fly and so on(as fig.2 fig3),so we advise sensitivity hadn't be adjusted to the max.



Fig.2

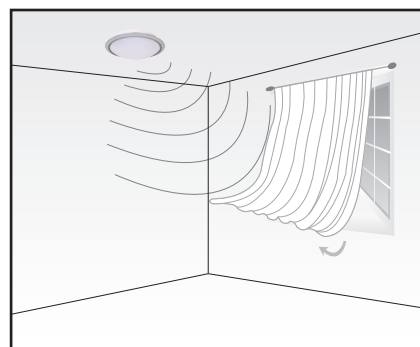
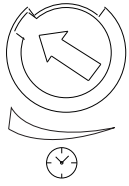

Fig.3

Time setting



The light can be set to stay ON for any period of time between approx. 8sec(turn fully anti-clockwise) and a maximum of 30min(turn fully clockwise). Any movement detected before this time elapse will re-start the timer. It is recommended to select the shortest time for adjusting the detection zone and for performing the walk test.

NOTE: After the light switches OFF, it takes approx. 1sec before it is able to start detecting movement again. The light will only switch on in response to movement once this period has elapsed.

It is mainly for the adjustment of the delay time from the moment the signal detected and light auto-on till the light auto-off. You can define the delay time to your practical need. But you'd better lower the delay time for the sake of energy saving, since the microwave sensor has the function of continuous sensing, that is, any movement detected before the delay time elapses will re-start the timer and the light will keep on only if there is human in the detection range.

Warning: in the process of installation test ,please far away from the sensor lamp,because it will turn on once detect you or test staff.

Please keep a certain distance with sensor lamp when test,otherwise,the sensor lamp will turn on once detect you in the detection range.

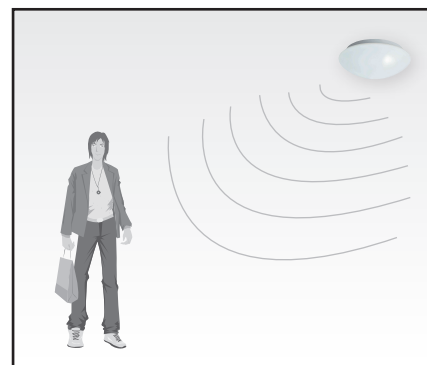
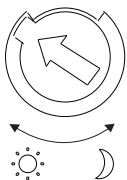

Fig.4

Light-control setting



The chosen light response threshold can be infinitely from approx. 10-2000lux. Turn it fully anti-clockwise to select dusk- to-dawn operation at about 10 lux. Turn it fully clockwise to select daylight operation at about 2000lux. The knob must be turned fully clockwise when adjusting the detection zone and performing the walk test in daylight.

LUX knob is used to adjust sensor lamp where can turn on by sensor ,in addition,we can choose suitable location according to the needs of customer.

Installation location:

Due to the existence of a light transducer in sensor lamp(as fig.5), the light transducer must keep in the location where daylight is sufficient, on the other hand,we have to avoid other light source,otherwise,the light transducer will do a improper judgment for environment ray. Due to the needs of different customers,such as installation location,lux and so on ,the location of potentiometer knob is different.when used, it maybe require you to adjust many times in order to meet with your needs.

Change the location of light transduce to the location where the daylight is visible.(as fig.6)

Note: Please don't adjust the three functional buttons to excess. That is because the three functional buttons were connected to the components directly, there is a small stopper in each of the three components, when you adjust the buttons from start to end, the excessive turn will damage the stopper, and lead to the 360°non-stop turn around. The adjust range limit is 270°, please do pay attention to this.

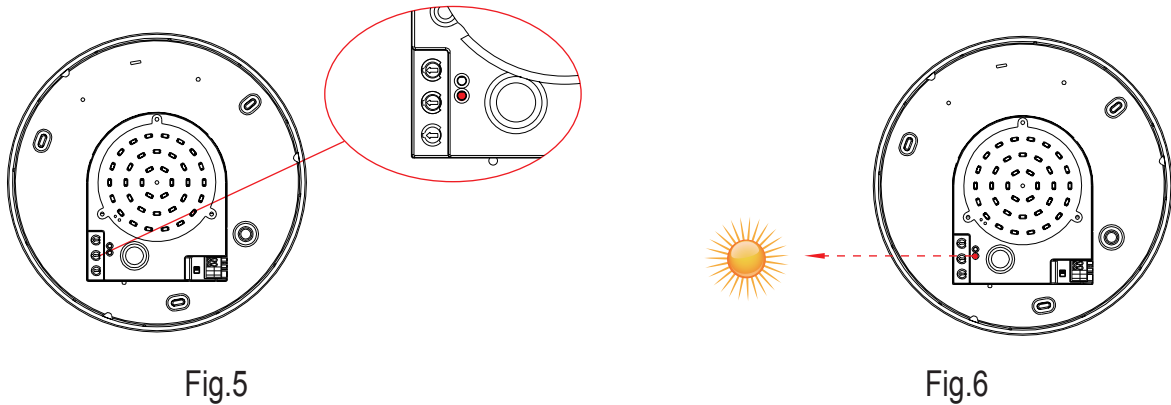

Procedure of installation



Warning!

1. Please keep it away from the children when installation.
2. Please avoid to be installed where the temperature or humidity is high.
3. Please cut off the power before installation.

Note:Please bring the following tools.



Pencil

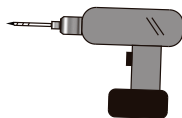

Electric drill

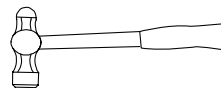

Hammer



Screwdriver

- Step1 Separate the lamp into two parts:A and B.

NOTE: Chimney is fragile, please don't take too much force.

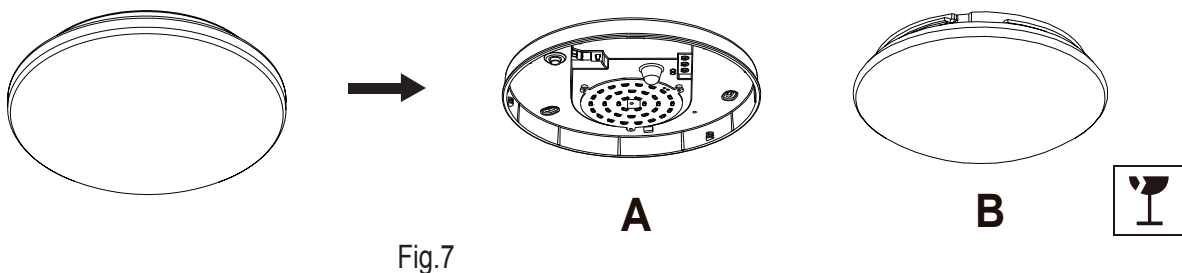

- Step2 Turn the knobs to the ideal conditions
(Please define the settings as per the above FUNCTION part mentioned.).

- Step3 Put the base of the product on the ceiling to make the drilling mark (as Fig.8)
- Step4 Install the product on the place where you marked (as Fig.9)
 Products should be installed more than 4 meters one from the other, otherwise the interference among them will cause error action.

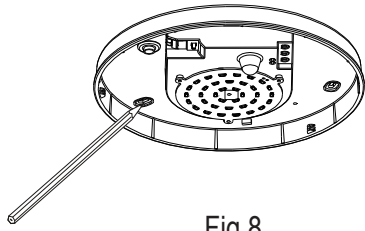

Fig.8

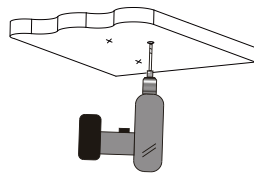
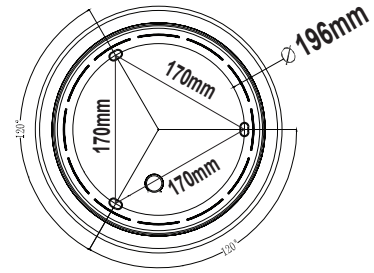

Fig.9



- Step5 Knock the plastic expansion screw into the hole which you drill (as Fig.10)
- Step6 Put the power line through the line hole to connect on the wiring (as Fig.11)

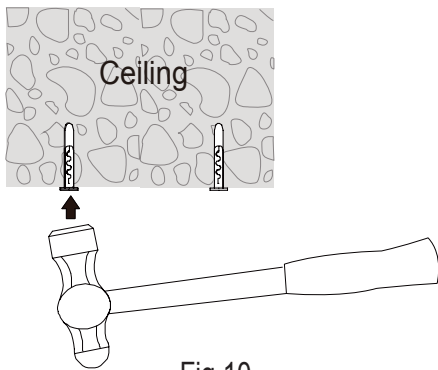

Fig.10

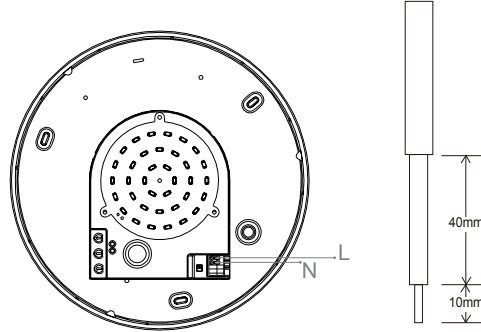

Fig.11

- Step7 Fix the base of the product on the selected place with the screws (as Fig.12)

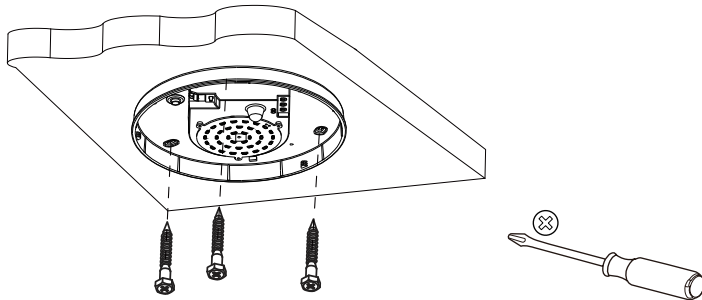
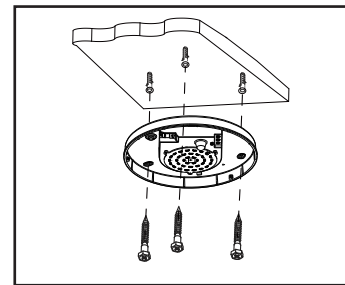

Fig.12



Concrete ceiling

- Step8 Rotate the lampshade clockwise into the base. Installation finished. (as Fig.13)

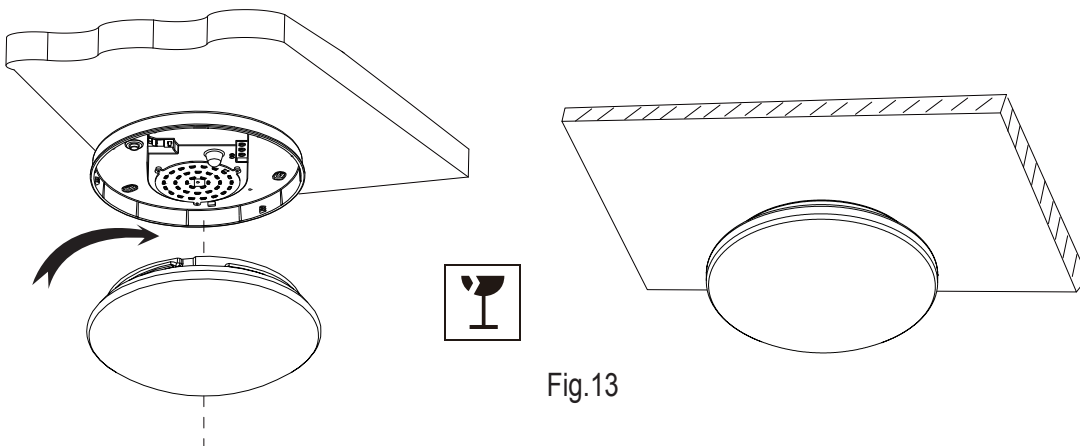
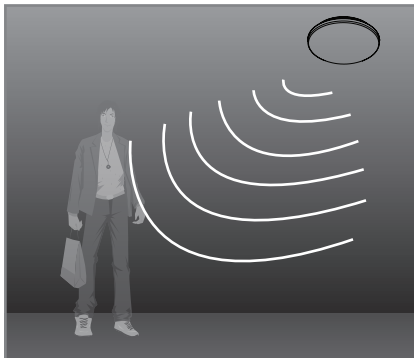
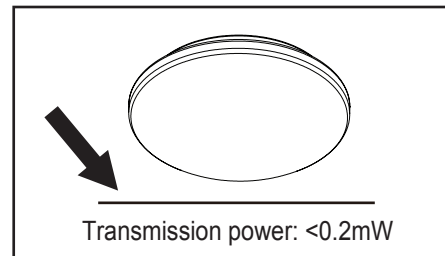

Fig.13

Fault and the solution

Fault	Failure cause	Solution
The load fails to work.	Light-illumination is set incorrectly.	Adjust the setting of the load.
	The load is broken.	Change the load.
	The power is off.	Turn the power on.
The load works all the time.	There is a continuous signal in the region of the detection.	Check the settings of the detection area.
The load works when there is no motion signal detected.	The lamp isn't installed well so that sensor fails to detect reliable signals.	Re-adjust the installation place.
	Moving signal is detected by the sensor (movement behind the wall, the movement of small objects, etc.)	Check the settings of the detection area.
The load fails to work when there is motion signal detected.	The motion speed is too fast or the defined detection area is too small.	Check the settings of the detection area.

Note: the high-frequency output of this sensor is $<0.2\text{mW}$ - that is just one 5000th of the transmission power of a mobile phone or the output of a microwave oven.



Induction of human movement



Since entering lighting condition



Application





Warning!

- 1.The LEDS in serial can function when all the seals installed in place.**
- 2.Please don't remove or connect with other lamp when powered on.**
- 3.When the LEDS in serial are damaged ,you need experienced technician to repair using the same rating LEDS.**

- Please confirm with profession installation.**
- Please cut off power supply before installation and removal operations.**
- Make sure that you have cut off the power for safety purposes.**
- Improper operation caused losses, the manufacturer does not undertake any responsibility.**

We are committed to promoting the product quality and reliability, however, all the electronic components have certain probabilities to become ineffective, which will cause some troubles. When designing, we have paid attention to redundant designs and adopted safety quota to avoid any troubles.

This instruction, without our permission, should not be copied for any other purposes.