

Product size

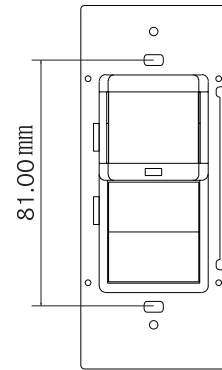

Mounting holes

**PRODUCT INFORMATION**

This product is a new energy-saving lighting switch, it adopts high sensitivity detector, integrated circuit, controllable Silicon and SMT; It gathers automatic, convenient, safety and practical functions; The wide detection range is made up of the up and down, left and right service field; It utilizes the infrared energy from Human Body as the control-signal source, When one enters the detection field, it will start the controlled load; It can identify day and night automatically; Its installation is convenient and its range is wide; It has the functions of the power indication and the detection indication.

**SPECIFICAIONS**

Power source: 100V/AC~277V/AC  
 Power frequency: 50/60Hz  
 Detection angle: 180°   
                           140°   
 Detection range: 8m(22°C)  
 Working temperature:-10~+40°C

Light-control: 2~1000LUX(adjusted)  
 Time setting: min:8sec±3sec  
                           max:7min±2min  
 Rated Load: 350W.max (120 V/AC incandescent lamp)   
                           500W.max (277 V/AC incandescent lamp)   
 Installation height: 1m~1.6m

**FUNCTION**

- ▶ Detection field: The wide range is made up of up and down, left and right service field.(See the following diagram 1), the moving orientation has relationship with the sensitivity, please consider it carefully when you select the installation position.
- ▶ It can identify day and night automatically: This product has been adjusted to the maximum before leaving factory. But it also can be adjusted according to client's desire.
- ▶ Detection indication: The indicator lamp can flash one time when the sensor receives one signal, that show the detection is regular.
- ▶ Time-delay is added continually: When it receives the second induction signals after the first induction, it will compute time once more on the basic of the first time-delay's rest. (Set time)
- ▶ Touching detection: The sensor will start the load when human touch the touching-line;( subjoined)
- ▶ Time-delay is adjustable: It can be set according to the consumer's desire. The minimum time is 8sec±3sec,the maximum time is 7min±2min.
- ▶ Touch-tone switch: AUTO, OFF, ON.

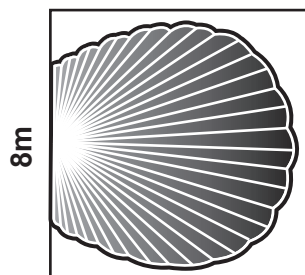

8m  
8m  
**Correct moving orientation**

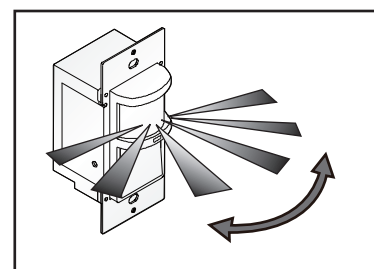

**180° / 140°  
Induction Angle**

**INSTALLATION** (See the following diagram)



**Warning!**

1. Please keep it away from the children.
2. Please avoid fire/high temperature/damp places for installation.

- ▶ Shut off the power.
- ▶ Connect the power and the load wire with the sensor according connection-wire diagram.
- ▶ Lift the board-face off. Fix the sensor on the selected position with bolt.
- ▶ Cover the board-face and screw the bolt, then you can switch on the power to test it .



**Warning!**

Please confirm when shut off the power cord access.

- 1.Wall brick has been confirmed in installation chassis.
- 2.Will power access corresponding position.

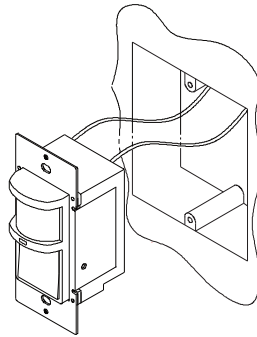
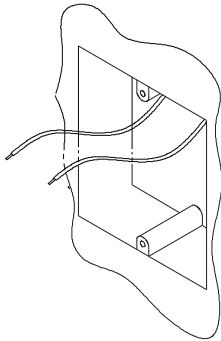

**Connection-wire diagram**

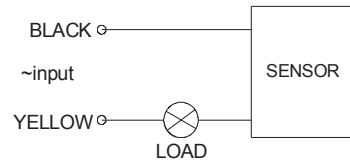

- 3.Induction switch to fixed to the base.
- 4.Pack cover screw in screw.

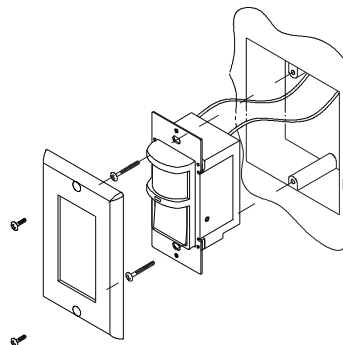
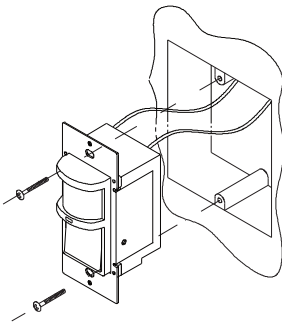

**TEST**

- ▶ Lift the board-face off, turn the time knob anti-clockwise to minimum; turn the "LUX" clockwise to maximum, set press-button to "AUTO".
- ▶ After switching on the power, the controlled load should work, the indicator lamp should flash one time, the load should stop working within 10sec; make it sense after 10sec, the indicator lamp should flash one time and load should start working, under the conditions of no induction signal, the load should stop working within 5~15sec.
- ▶ Turn "LUX" to minimum anti-clockwise, cover the detection window with opacity object (towel), the load should work within 5~10sec, (the sensor should work continually after it detect the continual induction signal if the load is still working), the load should not work after 10sec; if it is inducted again,the load should work, under no induction signal condition, it is regular the load stops working within 5~15sec.
- ▶ Press the press-button to "OFF",the sensor should shut off theload; Press it to "ON", the sensor should work continually.

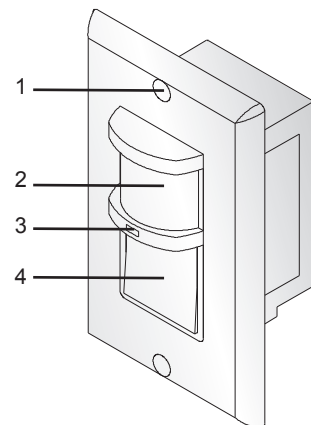

- 1.INSTALLATION HOLE
- 2.DETECTION WINDOW
- 3.INDICATOR LAMP
- 4.FUNCTION SWITCH

## NOTES

- ▶ Electrician or experienced human can install it.
- ▶ The unrest objects can not be regarded the installation basis-face.
- ▶ There isn't hinder or unrest objects effecting detection in front of the detection window
- ▶ Avoid installing it near temperature alteration zones, for example: air condition, central heating etc.
- ▶ Please do not open the case for your safety if you find the hitch after installation.
- ▶ If there are some difference between instruction and product, please give priority to the products, sorry not to give information additionally.

## SOME PROBLEM AND SOLVED WAY

- ▶ **The load do not work:**
  - a: Check the power and the load.
  - b: If the load is good.
  - c: Please check if the switch is on the "auto" position.
  - d: Please check if the working light corresponds to the ambient-light.
- ▶ **The sensitivity is poor:**
  - a: Please check if in front of the detection window there is hinder that effect to receive the signals.
  - b: Please check the ambient temperature is too high.
  - c: Please check if the signal sources are in the detection fields.
  - d: Please check the installation height.
  - e: If the moving orientation is correct.
- ▶ **The sensor can not shut off the load automatically:**
  - a: If there are continual induction signals in the detection fields.
  - b: If the time-delay is set to the longest.
  - c: If the power corresponds to the instruction.
  - d: If the temperature change near the sensor. (Air condition, central heating etc.)
  - e: If the function switch is "ON" position.



## **Warning!**

- **When used in different environments, please do not to adjust the sensitivity to the highest. Because that could easily lead to malfunction.**
- **Please confirm with professional installation.**
- **Please cut off power supply before installation and removal operations.**
- **Make sure that you have cut off the power for safety purposes.**
- **Improper operation caused losses, the manufacturer does not undertake any responsibility.**

### **Ningbo Pdlux Electronic Technology CO.,Ltd**

Add: 17F,Commerce Building of NingBo,  
No 588, South Tiantong Rode,Yinzhou District,Ningbo, China  
Tel: 86-574-83008608(20 lines) Fax: 86-574-83008609  
Email: pdlux@pdlux.com Web: www.pdlux.com