

# PD-PIR157 Infrared Sensor Instruction

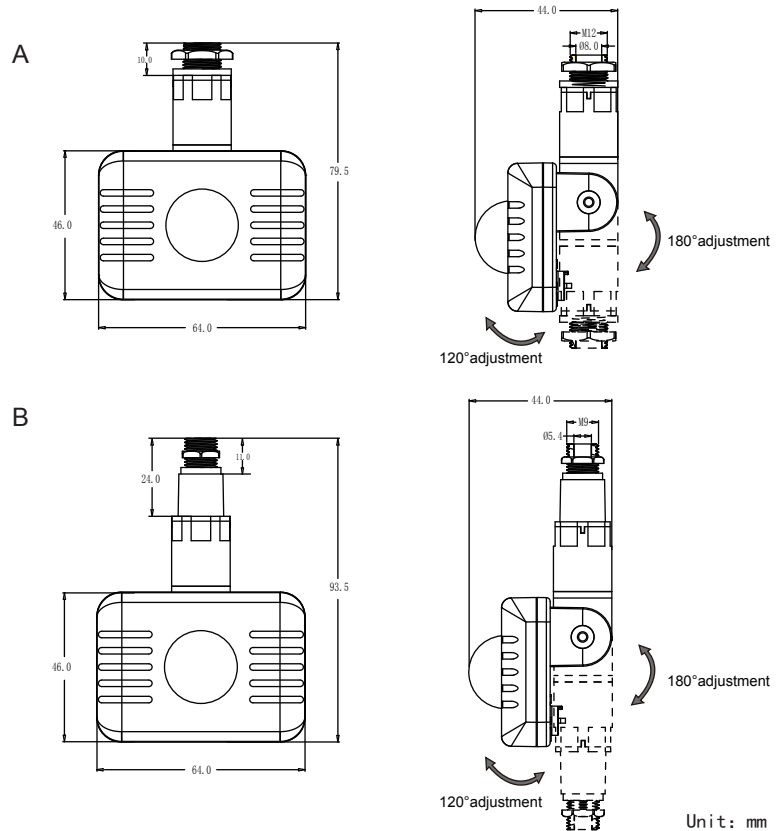

## Summary

The product is a PIR Pyroelectric intelligence switch , utilizes the infrared energy from human as control-signal source and determine the light to need to work or not, and control the light on and off automatically .When one enters the detection filed and trigger the sensor to work ,the light turns on; when one leaves the detection filed and the setting time reaches, the light will turn off.It can detect the ambient light illumination automatically and set and adjust the value according to the fact need.Such as, the light will turn on and works when the ambient light illumination is under setting value. once it exceeds the setting value, the light will stop working.

## Specifications

Power source: 100-240VAC, 50/60Hz

Rated load: 0.5A Max. (any load)

Standby power: <0.2W

Time setting: 8s-9min(Adjustment)

Light-control: <10LUX->300LUX(Adjustment)

Detection motion speed: 0.6-1.5m/s

Detection angle: 120°

Detection range: 2-10m (24°C)

(Wall installation)

Working temperature: -10~+40°C

Working humidity: ≤95%RH

Installation height: 1.8m~2.5m (Wall installation)

Product Color: Black /White

IP: 44

## Function

- Can identify day and night: the light control can be adjusted freely when it works. It can work in the daytime and at night when it is adjusted on the “sun” position (max); but it can only work in the light control less than 10lux when it is adjusted on the “moon” position (min). As for the adjustment pattern, please refer to the testing pattern.
- Time delay can be added continually: when it received the second induction signal after the first it will compute time once more on the rest of the first time delay basic.(Set time)
- It can be defined in the range of 10~>300 LUX. To turn the knob fully clockwise is about 10 lux,fully anti-clockwise is about 300 lux.When adjusting the detection zone and performing the walk test in daylight,you should turn the knob fully clockwise.
- It can be defined from 8 seconds(turn fully anti-clockwise) to 9 minutes(turn fullyclockwise). Any movement detected before this time elapses will re-start the timer. It is recommended to select the shortest time for adjusting the detection range and for performing the walk test.

## Sensing information

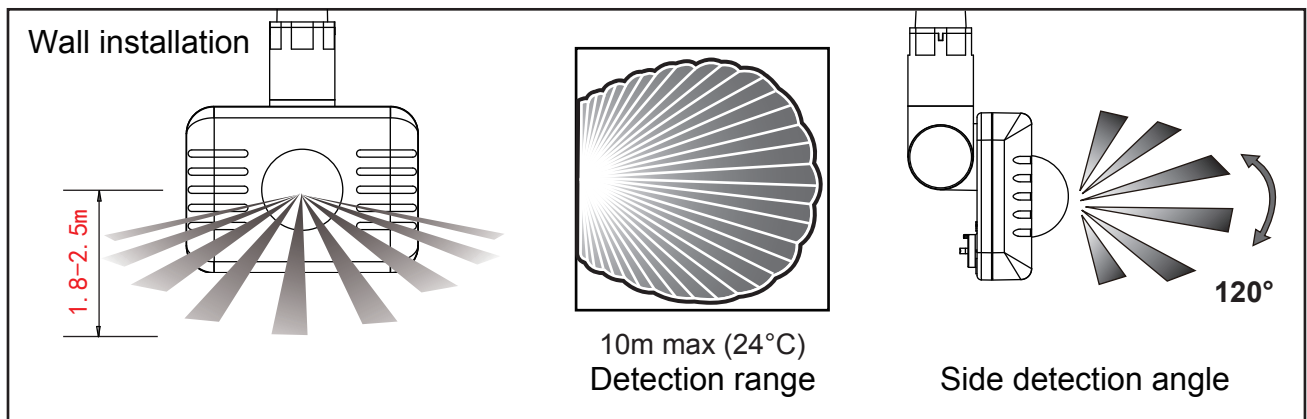

## The name of each part

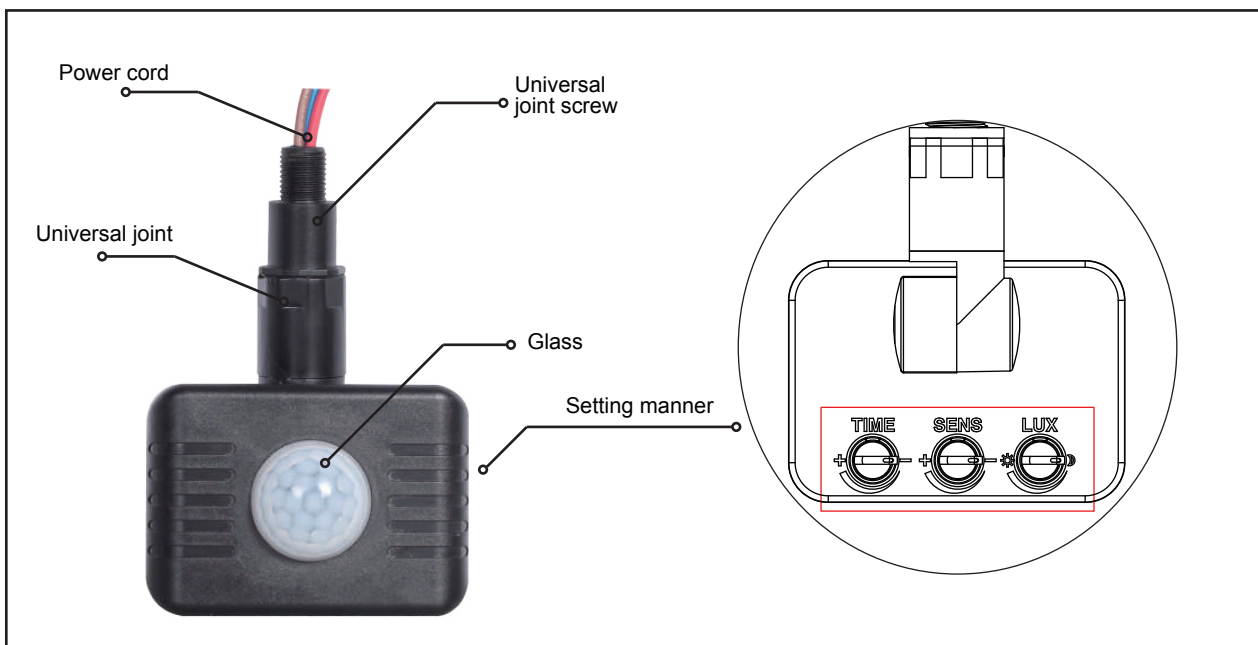

# Setting manner :potentiometer

## (1)Time-delay setting

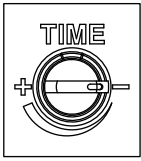

It can be defined from 8 seconds(turn fully anti-clockwise) to 9 minutes(turn fullyclockwise). Any movement detected before this time elapses will re-start the timer. It is recommended to select the shortest time for adjusting the detection range and for performing the walk test.

**NOTE:**When the light be auto off,it will take 3 seconds before the sensor is ready to detect another movement,that is,only signal detected later can the light be auto-on.

## (2)Detection range setting

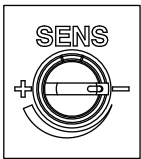

Turn clockwise to increase it and turn anti-clockwise to decrease it. It is 2-4m when turn to mini, and it is 10m when turn to max.

## (3)Light-control setting



It can be defined in the range of 10~>300 LUX. To turn the knob fully clockwise is about 10 lux,fully anti-clockwise is about 300 lux.When adjusting the detection zone and performing the walk test in daylight,you should turn the knob fully clockwise.

## Installation

I.Connect line according to the right figure.

N-Blue

L-Brown

L'-Red (be from infrared sensor)

Connect brown and blue with power;Connect red and blue with load,the color of lead can be changed according to the requirements of different countries.

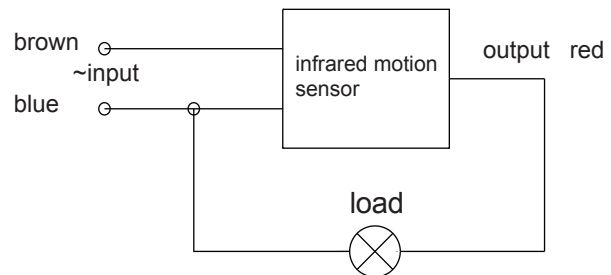

- II. 1.Unscrew the lamp junction box cover screw;
- 2.The sensor is installed on the lamp;
- 3.According to the wiring diagram for wiring;
- 4.Close the lamp junction box cover, tighten the screws.



Note:Length of wire can be adjusted according to requirements.

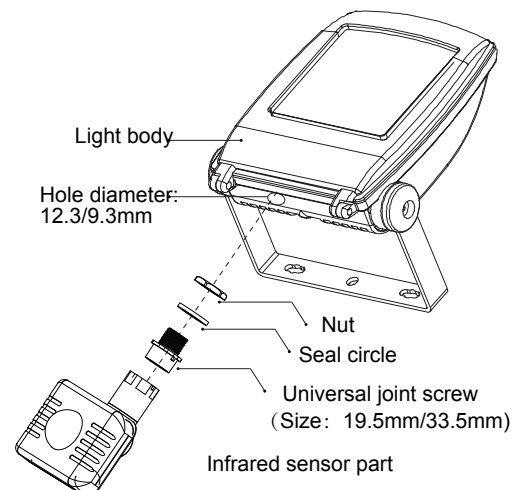

## Test

1. Time adjustment knob (TIME): The user can select the delay time according to the need, usually in the installation of measurement, the time adjustment knob (TIME) to a minimum, so that the installation inspection quick and easy. After installation can be 8 seconds ~ 9 minutes  $\pm$  2 minutes arbitrarily selected lights out time, set the time and confirm the test time, the sensor head should be as far down as possible, so as not to move the front of the sensor signal, resulting in the set time is not quasi;
2. Illumination adjustment knob (LUX): The user can use this knob to select under what kind of ambient light (daytime to nighttime), the sensor enters the value of automatic induction lighting. Usually 3LUX is shown as night, 100LUX ~ 2000LUX should be daytime value. Therefore, the first time setting, the user can adjust the LUX knob according to their needs;
3. Sensitivity adjustment knob SENS (detection distance adjustment knob): The maximum detection distance of the sensor is the maximum distance of 10 meters when the ambient temperature is 24 °C. If the ambient temperature is too high, the detection distance will be reduced. High sensitivity in winter and low sensitivity in summer, the user can adjust the SENS knob according to the size of the area to make the sensor automatically sense the distance required by the user.

**ATTENTION: When use this product, please adjust the sensitivity to an appropriate position you need, please do not adjust the sensitivity to maximum, to avoid the product does not work normally caused by wrong motion. Because the sensitivity is too high easily detect the wrong motion by wind blowing leaves & curtains, small animals, and the wrong motion by interference of power grid & electrical equipment. All those lead the product does not work normally !**  
**When the product does not work normally, please try to lower the sensitivity appropriately, and then test it.**

**Attention: when testing it in the daytime, you should adjust the LUX knob to the position, otherwise the sensor will not induct the lamp on!**

## Special attentions

1. Avoid installing the unit on the wagging object, for example the tree, etc. because the wagging will lead the sensor to induct; falsely and make the lamp on.
2. Avoid installing the unit where the sunshine is exposed directly.
3. Don't install the unit where there is much rain. Because the induction sensitivity will reduce where there is much rain.
4. Don't make the unit facing the public road, because the person moving on the public road and the high temperature gas also probably lead the lamp on.
5. The unit's sensitivity is very high to human body's moving breadthwise. but it is very low to moving frontal. So when installing it , you should select a position that a moving object can move breadthwise with the sensor, so that the sensor work reliably.

## Some problem and solved way

- 1、 **The load do not work:**
  - a: Please check if the connection-wiring of power and load is correct;
  - b: Please check if the load is good ;
  - c: Please check if the working light set correspond to light-control.
- 2、 **The sensitivity is poor:**
  - a: Please check if there has hinder in front of the detection window to effect to receive the signal;
  - b: Please check if the ambient temperature is too high;
  - c: Please check if the induction signal source is in the detection fields;
  - d: Please check if the installation height corresponds to the height showed in the instruction;
  - e: Please check if the moving orientation is correct.
- 3、 **The sensor can not shut off the load automatically:**
  - a: Please check if there is continual signal in the detection field;
  - b: Please check if the time setting is the longest;
  - c: Please check if the power correspond to the instruction;
  - d: Please check if the temperature near the sensor change obviously, such as air condition or central heating etc.

## **Warning!**

- **When used in different environments, please do not to adjust the sensitivity to the highest. Because that could easily lead to malfunction.**
- **Please confirm with professional installation.**
- **Please cut off power supply before installation and removal operations.**
- **Make sure that you have cut off the power for safety purposes.**
- **Improper operation caused losses, the manufacturer does not undertake any responsibility.**

**We are committed to promoting the product quality and reliability, however, all the electronic components have certain probabilities to become ineffective, which will cause some troubles. When designing, we have paid attention to redundant designs and adopted safety quota to avoid any troubles.**

**This instruction, without our permission, should not be copied for any other purposes.**