

PD-PIR109-Z Infrared Motion Sensor Instruction

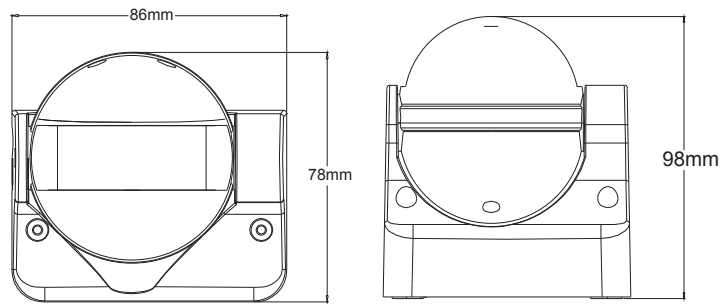

Summary

This product is an advanced digitally controlled infrared pyroelectric intelligent sensor product. It uses the MCU to accurately calculate the switch information, and accurately controls the relay to be turned on at the zero point of the sine wave, so that each load is turned on. At the zero point of the sine wave, the inrush current problem caused by the conventional control mode when the sine wave high voltage is turned on is avoided, especially the large current damage relay generated by the large-capacity capacitor under the impact of the high voltage under the load.

Due to the diversification of current electrical loads, especially LED lamps, energy-saving lamps, and fluorescent lamps all have capacitors with different capacitances. This is a disaster for relays. Sometimes a 50W LED lamp can generate surge currents of 80 to 120A. The 10A ordinary relay can only withstand 3 times of the inrush current, and it is likely that the relay will be broken in a few days or several times. This is why the conventional sensor on the market has a short life and a small load current.

In order to overcome this problem, this product adopts advanced digital precision calculation to turn on the load when the sine wave is at zero potential, thus solving the load surge current problem, greatly enhancing the load capacity and prolonging the service life of the product. The latest control method of mass production sensor technology can easily control any load. It is a medium and high-end product. Although the cost is increased compared with the conventional version, the reliability and life of the product are greatly increased. This product is equal to choosing peace of mind, choosing peace of mind, and choosing safety.

This product has a switching power supply version and a capacitor step-down version. The switching power supply version has a working voltage of up to 100V-277V and a standby power consumption of <0.5W. In principle, the capacitive step-down version can only have a single voltage, and the standby power consumption is >0.7W. You should consider it when choosing a product.

Specifications

Power source: 220-240VAC 50Hz/60Hz
100-130VAC 50Hz/60Hz

All loads: 1200W Max. (220-240VAC)
800W Max. (100-130VAC)

Time setting: 10sec-12min (adjustable)

Light-control: < 10LUX-2000LUX (adjustable)

Detection range: 12m Max (22°C)

Detection angle: 180°

Working temperature: -10°C -+40°C

Working humidity: <93%RH

Installation height: 1.8m~2.5m

Detection motion speed: 0.6-1.5m/s

Function

➤ LUX adjustment:

LUX refers to the illuminance of the environment. Adjusting the LUX adjustment knob allows you to choose which illuminance you want to get the sensor into the induction. Choose the habit that suits you.

Some of the choices in the 20LUX solution are to be illuminated. Some choose 50LUX ambient illumination to be inductive lighting, and some choose to be inductive lighting at any time, as long as the LUX adjustment knob is adjusted to the maximum.

➤ Time adjustment:

The time adjustment knob is used to adjust the time after the sensor senses the light, and the user can reasonably select the delay time after the induction.

Sensor information

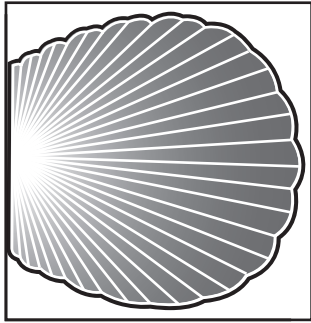

12m

Detection range (22°C)

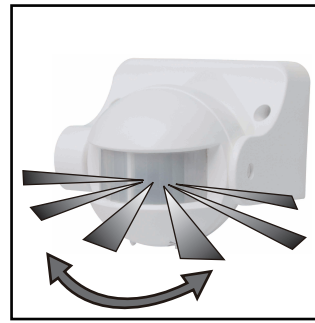

180°

Detection angle

Installation and precautions

This product is very convenient to install, choose a suitable position for precise installation, try not to install the sensor in a place with large environmental interference; for example, air conditioning port, heat source port and other locations. Because these positions are likely to cause the sensor to malfunction, after selecting the installation position and correctly connecting the power cable to the load cable, the power can be turned on.

1. Firstly, adjust the TIME to the minimum, then adjust the LUX to the maximum (the working position during the day) and test the induction.

2. If the sensor has been illuminated during the test, there is no one in front of the sensor. It must wait until the lamp is turned off, and it will be triggered by the human body movement again after 3 seconds. If there is always someone moving the light in the middle, it will always be on and cannot be turned off.

3. After the above preliminary test is normal, you can choose the appropriate LUX value and delay time.

Connection-wire diagram

L Brown

N Blue

L' Red

connect L and N with power;

connect L' and N with load.

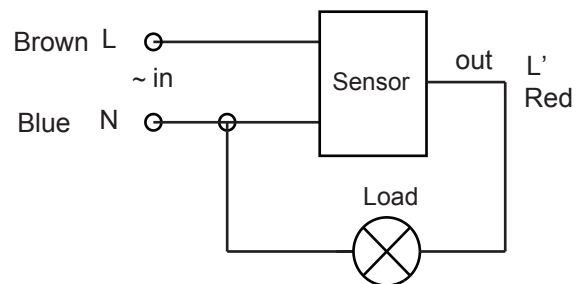

Installation

- 1、 Shut off power;
- 2、 Loosen the screw on the bottom lid, open the wiring hole, pass the wire of power and load through the bottom lid;
- 3、 Fix the bottom lid with inflated screw on the selected position;
- 4、 Connect the power and load wire into connection-wire column according to the connection-wire diagram;
- 5、 Put the sensor on the bottom lid, twist the screw tightly then electrify it and test it.

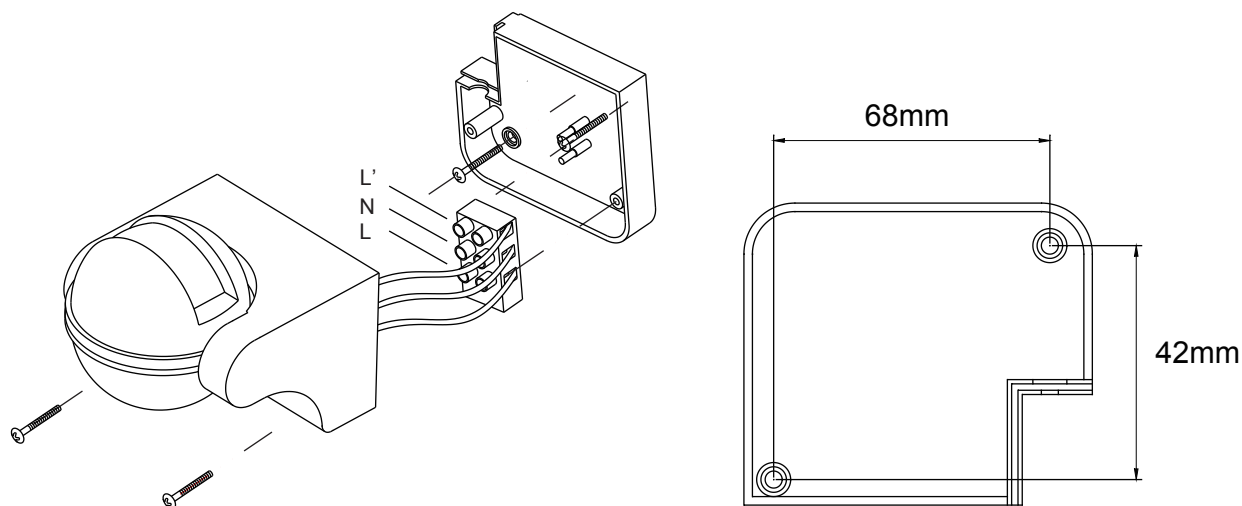

Test

- Turn the light-control knob clockwise to the maximum (SUN), turn time knob anti-clockwise to the minimum;
- Turn on the power, and the indicator will flash for 30sec and enter the working state;
- When the load is extinguished for the first time, make it sense again after 5sec, the load should work and the indicator lamp is red. The load should stop to work within 5sec;
- Turn LUX knob to minimum anti-clockwise, if you test it when the light-control is more than 10LUX, the induction load would not work after the load stops working; the load should work if you cover the detection window with opaque object (towel etc), it would be regular the load stops to work within 5sec under no induction signal condition.

Note

- Should be installed by electrician or experienced person;
- Avoid installing it on the unrest object;
- There should be no hindrance and moving objects in front of the detection windows to effect detection;
- Avoid installing it near air temperature alteration zones such as air condition, central heating, etc;
- Considering your safety, please do not open the cover when you find the hitch after installation;
- If there is difference between instruction and the function the product has, please give priority to product and sorry not to inform you additionally.

Some problem and solved way

- 1、 **The load do not work:**
 - a: Please check if the connection-wiring of power and load is correct;
 - b: Please check if the load is good ;
 - c: Please check if the working light set correspond to light-control.
- 2、 **The sensitivity is poor:**
 - a: Please check if there has hinder in front of the detection window to effect to receive the signal;
 - b: Please check if the ambient temperature is too high;
 - c: Please check if the induction signal source is in the detection fields;
 - d: Please check if the installation height corresponds to the height showed in the instruction;
 - e: Please check if the moving orientation is correct.
- 3、 **The sensor can not shut off the load automatically:**
 - a: Please check if there is continual signal in the detection field;
 - b: Please check if the time setting is the longest;
 - c: Please check if the power correspond to the instruction;
 - d: Please check if the temperature near the sensor change obviously, such as air condition or central heating etc.



Warning!

- Please confirm with professional installation.
- Please cut off power supply before installation and removal operations.
- Make sure that you have cut off the power for safety purposes.
- Improper operation caused losses, the manufacturer does not undertake any responsibility.

We are committed to promoting the product quality and reliability, however, all the electronic components have certain probabilities to become ineffective, which will cause some troubles. When designing, we have paid attention to redundant designs and adopted safety quota to avoid any troubles.

This manual is for the current content programming of this product, there are any changes and modifications to the manufacturer without notice!

This instruction, without our permission, should not be copied for any other purposes.