

# PIR Sensor & Microwave Sensor Instruction

## PD-MV1008

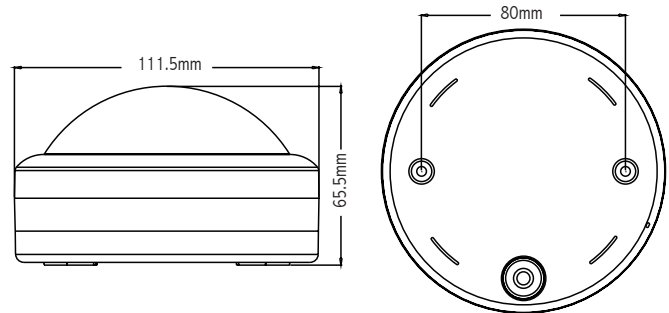

PD-MV1008 is a motion sensor whose detection range is 360° and it adopts the microwave sensor(working frequency is 5.8G Hz ,transmission power:<0.2mW) together with the PIR sensor, four working state can be choosed by preessing the button which is more stable and safer performance . It can be used where the ambient temperature is about -10℃~40℃ . PD-MV1008 is of high jam-proof ability and precise detection, it is widely applied with lamps, security systems etc.

### Specifications

Power source:100-240VAC

Power frequency:50/60Hz

HF system:5.8GHz CW radar, ISM band

Rated load:

1800W Max.(240VAC Incandescent  $\cos\phi=1$ )

500W Max.(240VAC Fluorescent  $\cos\phi=0.5$ )

900W Max.(100VAC Incandescent  $\cos\phi=1$ )

240W Max.(100VAC Fluorescent  $\cos\phi=0.5$ )

Installation height:2.5~3.5m(Ceiling installation)

Transmission power:<0.2mW

Standby power: <0.5W

Detection angle:360°

Detection range:2m-15m (adjustable)

Time setting:6sec-20min (adjustable)

Light-control:2-2000LUX (adjustable)

Detection motion speed:0.6-1.5m/s

PIR Working temperature: -10~+40℃

HF Working temperature: -10~+70℃

### Sensor information

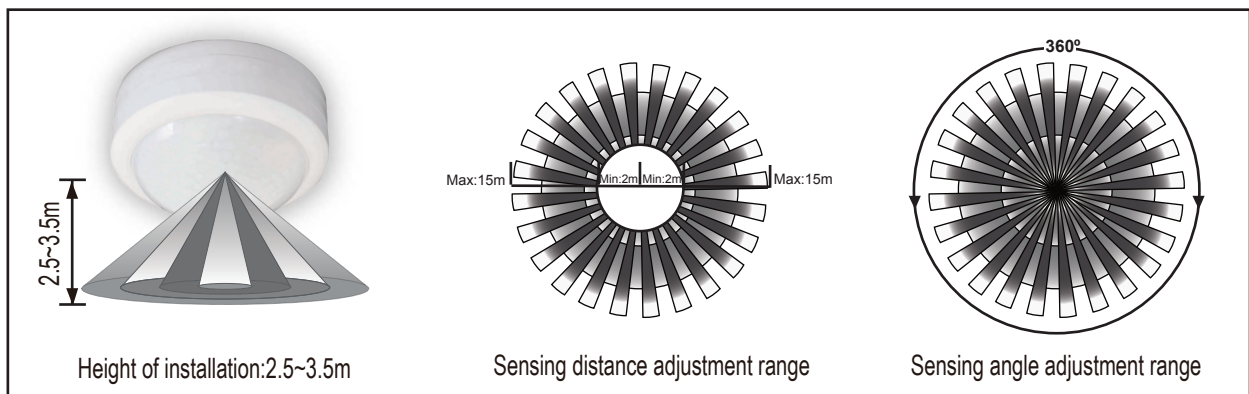

## Time setting



The light can be set to stay ON for any period of time between approx. 10sec (turn fully anticlockwise) and a maximum of 20min (turn fully clockwise). Any movement detected before this time elapse will re-start the timer. It is recommended to select the shortest time for adjusting the detection zone and for performing the walk test.

NOTE: after the light switches OFF, it takes approx. 1sec before it is able to start detecting movement again. The light will only switch on in response to movement once this period has elapsed.

## Detection range setting (sensitivity)

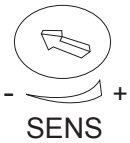

Detection range is the term used to describe the radii of the more or less circular detection zone produced on the ground after mounting the sensor light at a height of 2.5m, turn the reach control fully anticlockwise to select minimum reach (approx. 2m radii), and fully clockwise to select maximum reach (approx. 15m radii).

NOTE: the above detection distance is gained in the case of a person who is between 1.6m~1.7m tall with middle figure and moves at a speed of 0.6~1.5m/sec. if person's stature, figure and moving speed change, the detection distance will also change.

## Light-control setting



The chosen light response threshold can be infinitely from approx. 2-2000lux. Turn it fully anti-clockwise to select dusk- to-dawn operation at about 2 lux. Turn it fully clockwise to select daylight operation at about 2000lux. The knob must be turned fully clockwise when adjusting the detection zone and performing the walk test in daylight.

Note: please don't adjust the three functional buttons to excess. That is because the three functional buttons were connected to the components directly, there is a small stopper in each of the three

components, when you adjust the buttons from start to end, the excessive turn will damage the stopper, and lead to the 360° non-stop turn around. The adjust range limit is 270°, please do pay attention to this.

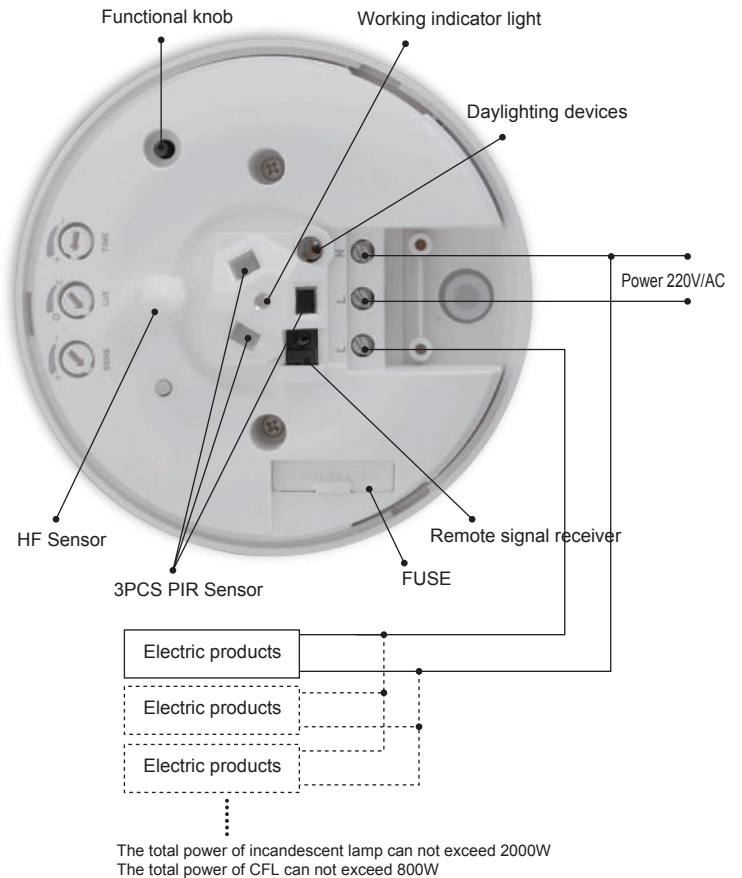

## PIR & Microwave sensor function choosing

### Choosing by the button:

- Press the button one time by cycle, can choose microwave sensor mode, pir sensor mode, microwave sensor & pir sensor mode microwave sensor or pir sensor mode in turn.
- Choosing microwave sensor mode, press the button one by one after the green led indicator bright about 5 seconds, then the product into the microwave sensor working state;
- Choosing pir sensor mode, press the button one by one after the red led indicator bright about 5 seconds, then the product into the pir sensor working state.
- Choosing the microwave sensor & pir sensor two functions together mode, press the button one by one after the green led and the red led indicator lights flash 5 times in turn and then the product into the microwave sensor & pir sensor two functions together mode working state.
- Choosing the microwave sensor or pir sensor two functions either mode, press the button one by one after the green led and the red led indicator lights bright at the same time and flash 5 times then the product into the microwave sensor or pir sensor two functions either mode working state.



## ATTENTION:

When use this product, please adjust the sensitivity to an appropriate position you need, please do not adjust the sensitivity to maximum, to avoid the product does not work normally caused by wrong motion. Because the sensitivity is too high easily detect the wrong motion by wind blowing leaves & curtains, small animals, and the wrong motion by interference of power grid & electrical equipment. All those lead the product does not work normally ! When the product does not work normally, please try to lower the sensitivity appropriately, and then test it.

## For occasions

Can be widely used in home\market\office building\factory\hotel\institution etc.



## **Warning!** The following situation will lead to misoperation

- When used in different environments, please do not to adjust the sensitivity to the highest. Because that could easily lead to malfunction.
  - Please confirm with professional installation.
  - Please cut off power supply before installation and removal operations.
  - Make sure that you have cut off the power for safety purposes.
1. Being installed in the rocking object will lead to misoperation.
  2. The shaking curtain which is blown by wind will lead to misoperation, please select the suitable installed place.
  3. Being installed in the place where the traffic is busy will lead to misoperation.
  4. It will lead to misoperation when there are sparks produced by some equipment nearby.

The detection distance may multiply for the reflection on microwave electromagnetic field by the metal or glass materials. Thus, lower the sensitivity to reach the appropriate detection distance. Never turn the SENS knob to the maximum value to avoid error detection. Also the surrounding environment will lead to error action, e.g. the automobiles passing by or the wandering objects caused by the wind. Products should be installed more than 4 meters one from the other, otherwise the interference among them will cause error action.

The proper use of trimming potentiometer: the trimming potentiometer is used to adjust the time that sensor load turn on when detects somebody movement and turn off automatically. The user can adjust the light time according to different needs. In order to carry out the saving-energy effectively, we suggest that we should decrease the close time automatically. In addition, due to the continuous sensor function of the load, simply speaking: Timer will time renewedly so as load has any induction. The load will keep open once detected movement within the detection range .

We are committed to promoting the product quality and reliability, however, all the electronic components have certain probabilities to become ineffective, which will cause some troubles. When designing, we have paid attention to redundant designs and adopted safety quota to avoid any troubles.