



Compact Electric Motor Linear Actuator



“AOX-L” series compact electric motor linear actuator is specially designed for linear operating valves such as globe valve and similar usages. It is widely used in water treatment, heating, petroleum, chemical industry, electronics, light industry, food, medicine, textile, paper making, hydropower, ships, smelting, new energy and other fields. In addition, it has established very friendly

relations with many Fortune 500 companies.

Compact Electric Motor Linear Actuator

Summary

“AOX-L” series compact electric motor linear actuator is specially designed for linear operating valves such as globe valve and similar usages. It is widely used in water treatment, heating, petroleum, chemical industry, electronics, light industry, food, medicine, textile, paper making, hydropower, ships, smelting, new energy and other fields. In addition, it has established very friendly relations with many Fortune 500 companies.

Product Introduction of the compact electric motor linear actuator

Precautions for installation of "AOX-L" series compact electric motor linear actuator are as follows.

1. The actuator shall be installed vertically upward as far as possible, and downward installation shall be avoided, which will bring difficulties to inspection and maintenance.
2. After the actuator is connected with the control valve through the bracket, the output shaft and the valve stem shall be connected with a split nut. There shall be a distance of 3 ~ 10mm between the lower end of the output shaft and the upper end of the valve stem.
3. In order to prevent water from entering the lead wire during external wiring, construction in rainy days should be avoided. After wiring, adjustment, inspection and maintenance, the shield should be fastened. Since the wiring, adjustment, inspection and maintenance of the actuator need to remove the shield, there should

Zhejiang Aoxiang Auto-Control Technology CO.,Ltd

Tel: [+86-577-59890750](tel:+86-577-59890750)

Phone: [+86-18967766527](tel:+86-18967766527)

Fax: [+86-0577-65921296](tel:+86-0577-65921296)

E-mail: zjaox@zjaox.com



Ambient humidity:	Max 90% RH	Non-Condensing
Anti-vibration:	X Y Z 10g,0.2~34 Hz,30 minutes	
Other faction:	Space heater with thermostat to prevent overheating; Provide a wide range of voltage; Strong structure, accurate positioning, reliable performance; Hand/auto clutch switching; Local control/auto hold; Modular design; Mechanical interlock	

Model	Thrust	Speed	Max travel	power	Rated current(A)	Weight
	N	mm/S	mm	W	220V/50HZ/1PH	Kg
AOX-L-30	3000	1	25	30	0.31	17.5
AOX-L-50	5000	1	40	45	0.42	19
AOX-L-80	8000	1	60	60	0.62	19.5
AOX-L-100	10000	1.5	100	60	0.68	33
AOX-L-160	16000	1.5	100	90	0.85	33
AOX-L-200	20000	1.5	100	90	0.87	33
AOX-L-250	25000	1.5	100	120	1.22	33
AOX-L-300	30000	1.5	100	120	1.28	33

Supplier Managementof the compact electric motor linear actuator

Our company has a complete and strict external supplier management system. In order to standardize the management of the supply channels of our company, purchased parts and external suppliers, establish a safe and stable supplier team to control the quality of our "AOX-L" series motor operated linear actuator.

Appearance drawing the compact electric motor linear actuator

Zhejiang Aoxiang Auto-Control Technology CO.,Ltd

Tel: +86-577-59890750

Phone: +86-18967766527

Fax: +86-0577-65921296

E-mail: zjaox@zjaox.com

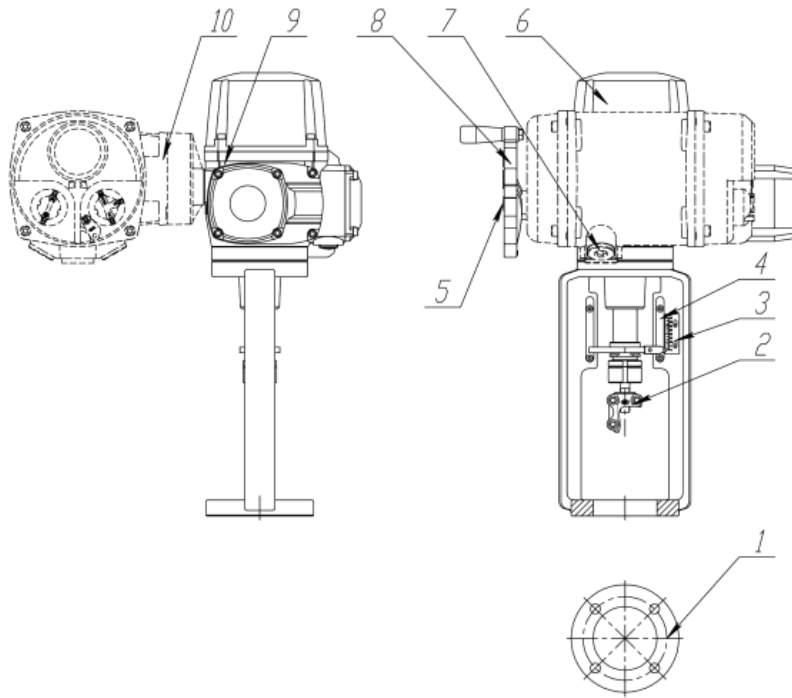

10	control room
9	shell
8	handwheel
7	plug
6	cover
5	Manual automatic switch button
4	guide
3	dividing rule
2	split nut
1	connecting flange