



www.aox-privod.com



Automation Electric Linear Actuator

AOX is an electric actuator supplier from China that integrates R & D, manufacturing and sales. "AOX-L" series automatic electric linear actuator is developed by AOX. It can move the valve to the required position and realize its automatic control. The thrust range of "AOX-L" series is 3000 ~ 30000NM, and the corresponding valve can be matched by different supports.

Automation Electric Linear Actuator

Summary

AOX is an electric actuator supplier from China that integrates R & D, manufacturing and sales. "AOX-L" series automatic electric linear actuator is developed by AOX. It can move the valve to the required position and realize its automatic control. The thrust range of "AOX-L" series is 3000 ~ 30000NM, and the corresponding valve can be matched by different supports.

Product Introduction of the automation electric linear actuator

The "AOX-L" series automation electric linear actuator has a handwheel construction. The design of the handwheel guarantees safety, reliability, energy saving and small size. Both manual and automatic clutch functions are available. In the event of a power failure, the user can switch to the manual state after the power supply has been cut off and operate the valve with the handwheel. In the absence of power, the electric actuator will remain in a permanent manual state, and when power is applied, it will automatically disengage the manual state and enter the

Zhejiang Aoxiang Auto-Control Technology CO.,Ltd

Tel: [+86-577-59890750](tel:+86-577-59890750)

Phone: [+86-18967766527](tel:+86-18967766527)

Fax: [+86-0577-65921296](tel:+86-0577-65921296)

E-mail: zjaox@zjaox.com



automatic state.



Product Parameter (Specification)of the automation electric linear actuator

Running speeds:	1 mm/s; 1.5 mm/s
Anti-vibration level:	JB/T 8219
Noise level:	Less than 75 dB within 1 m

Zhejiang Aoxiang Auto-Control Technology CO.,Ltd

Tel: [+86-577-59890750](tel:+86-577-59890750)

Phone: [+86-18967766527](tel:+86-18967766527)

Fax: [+86-0577-65921296](tel:+86-0577-65921296)

E-mail: zjaox@zjaox.com



Electrical interface:	IP67, Optional:IP68	
Signal Feedback:	Integrated fault contacts,Close the valve contact,Open the valve contact	
Input signal:	4 - 20 mA; 0 - 10 V; 2 - 10 V	
Output signal:	4 - 20 mA; 0 - 10 V; 2 - 10 V	
Loss Signal Mode Setting:	N/A	
Shell:	Enclosure :IP67,NEMA4 and 6	
Motor:	Asynchronous motor	
Auxiliary limit switch:	2×Open/ Close, SPDT,250VAC 10A	
External coating:	Dry powder, Epoxy polyester,high anti-corrosion	
Ambient humidity:	Max 90% RH	Non-Condensing
Anti-vibration:	X Y Z 10g,0.2~34 Hz,30 minutes	
Other facton:	Local control/auto hold; Modular design; Mechanical interlock。	

Model	Thrust	Speed	Max travel	power	Rated current(A)	Weight
	N	mm/S	mm	W	220V/50HZ/1PH	Kg
AOX-L-30	3000	1	25	30	0.31	17.5
AOX-L-50	5000	1	40	45	0.42	19
AOX-L-80	8000	1	60	60	0.62	19.5
AOX-L-100	10000	1.5	100	60	0.68	33
AOX-L-160	16000	1.5	100	90	0.85	33
AOX-L-200	20000	1.5	100	90	0.87	33
AOX-L-250	25000	1.5	100	120	1.22	33
AOX-L-300	30000	1.5	100	120	1.28	33

Our patents of the automation electric linear actuator

Zhejiang Aoxiang Auto-Control Technology CO.,Ltd

Tel: [+86-577-59890750](tel:+86-577-59890750)

Phone: [+86-18967766527](tel:+86-18967766527)

Fax: [+86-0577-65921296](tel:+86-0577-65921296)

E-mail: zjaox@zjaox.com



We have more than 100 invention patents, utility model patents and design patents.



Production details of the automation electric linear actuator

The valve connection of the "AOX-L" series electric actuators is carried out by means of different brackets, which can be adapted to different valves and can be selected by the customer according to his needs.

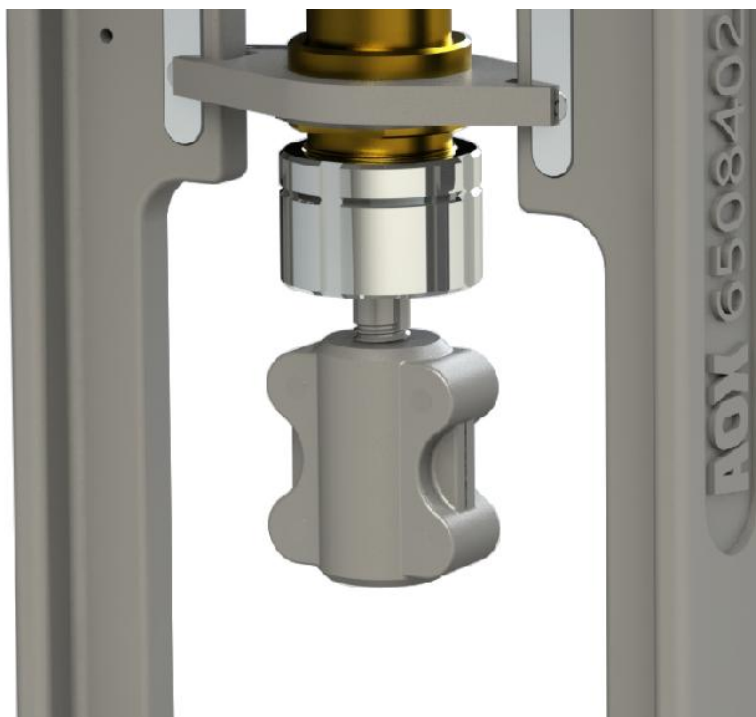

Zhejiang Aoxiang Auto-Control Technology CO.,Ltd

Tel: [+86-577-59890750](tel:+86-577-59890750)

Phone: [+86-18967766527](tel:+86-18967766527)

Fax: [+86-0577-65921296](tel:+86-0577-65921296)

E-mail: zjaox@zjaox.com