

## Hybrid Metal-Resin Diamond Wheel

Hybrid Metal-Resin Diamond Wheel is The New Generation Grinding Wheels (Hybrid Diamond /CBN Grinding Wheel)

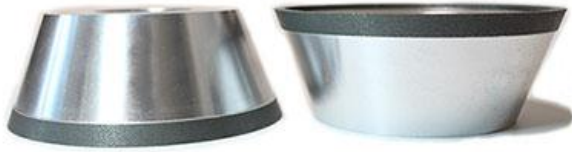

### Buy Wholesale Hybrid Metal-Resin Diamond Wheel Made in China

MORE® Offers A Perfectly Matched Range Of Products. Hybrid Metal-Resin Diamond Wheel Wheels Are Made Of A New Generation Hybrid Bond. The wheels combines the wear resistance of metal bonds with the sharp cutting of resin bonds. Hybrid Wheels Ensure Higher Material Removal Without Compromising On The Surface Finish, While Ensuring Considerable Reduction In Cycle Times. Hybrid Metal-Resin Diamond Wheel Wheels Can Be Used For Both Fresh Tool Manufacturing And Re-Sharpening, On CNC Tool And Cutter Grinders.

#### The Unique Properties Of The Hybrid Wheels:

Capable Of Taking Higher Depth Of Cuts, High Lubrication At The Point Of Grinding ,Lesser Load On The Spindle Motor, Increased Profile

Retention On The Wheel, Lower Grinding Force On The Work Place, Which Results In Lesser Work Place Deflection During Grinding.



**These Properties Of The Hybrid Bond Improve The Performance Of The CNC Tool And Cutter Grinder In The Following Ways:**

- \* Increased Rate Of Material Removal With High Temperature Stability
- \* Reduced Grinding Time Per Component
- \* Low And Constant Power Consumption
- \* High Profile Stability And Better Machine Productivity
- \* Long Wheel Life And Long Dressing Interval

**Applicable CNC tools Grinding Machine:** ANCA, Walter, SCHUTTE, EWAG, SCHNEEBERGER, HUFFMANN And So On. Have Shown Excellent Grinding Performance In flute Grinding With High Stock Removal Capacity Combined With A Minimum Of Wheel Wear. It Is Not Necessary To Reduce The Infeed or The Impact Rate With Our Hybrid Diamond/ CBN Grinding Wheel.

**The comparison between Hybrid Diamond/CBN Grinding Wheel and usual grinding wheel:**

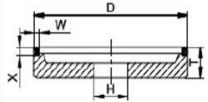
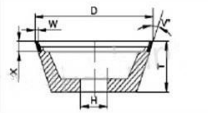
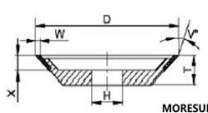
	Models	Profile Drawings
Clearance Angle Grinding	6A9, Diamond/CBN	
	11V9 Diamond/CBN	
	12V9 Diamond/CBN	

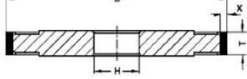
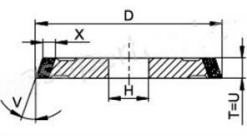
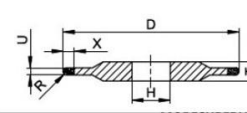
	Models	Profile Drawings
Flute Grinding	1A1/14A1 Diamond/CBN	
	1V1 Diamond/CBN	
	14F1 Diamond/CBN	

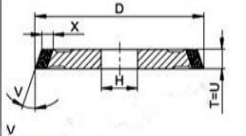
	Models	Profile Drawings
Gashing Wheel	1V1 Diamond/CBN	
	12V9 Diamond/CBN	