

## CBN Grinding Wheel For Band Saw Blade Sharpening



The electroplated CBN grinding wheel is specially used for the grinding of band saw chain. The electroplating process on the surface of the CBN grinding wheel for band saw blade sharpening obtains precision, ensures high-quality tooth shapes, and make the band saw chain blade sharper.

### China Wholesale CBN Grinding Wheel For Band Saw Blade Sharpening Factory

Item name: CBN grinding wheel for band saw blade sharpening

Abrasive: CBN

Model Number: 1F1

Bond: Electroplated

Body: 45#Steel

Diameter(D): 127mm(5 inch)/ 150mm(6 inch)/ 203mm(8 inch)

Thickness(T): 22.2mm

Center Hole(H): 12.7mm/20mm/25.4mm/32mm

Grit: B126 120/140#

Usage: The electroplated CBN grinding wheel is specially used for the grinding of the band saw chain. The electroplating process on the surface of the CBN grinding wheel for band saw blade sharpening obtains precision, ensures high-quality tooth shapes, and make the band saw chain blade sharper. Adhering towards the theory of "quality, support, efficiency and growth", we've attained trusts and praises from domestic and international client for China OEM China 125mm High Quality Electroplated CBN Diamond Grinding Wheels, Our company is working by the operation principle of "integrity-based, cooperation created, people oriented, win-win cooperation". We hope we can have a friendly relationship with businessman from all over the world. China OEM China 125mm, CBN Grinding Wheel, Our factory insists on the principle of "Quality First, Sustainable Development", and takes "Honest Business, Mutual Benefits" as our developable goal. All members sincerely thanks for all old and new customers' support. We are going to keep working hard and offering you the highest-quality products and solutions and service. Thanks.

Following is the conventional size of this type of grinding wheel:

5 inch: D127mm-T22.2mm-H12.7mm

6 inch: D150mm-T22.2mm-H20mm

8 inch: D203mm-T22.2mm-H32mm



Conventional sizes are in stock all year round, and CBN grinding wheels can be customized according to the customer's machine band saw blade.

Characteristics of different angle band saw wheels:

10/30: Commonly used universal grinding wheel profiles, softwood and hardwood band saws can be used;

9/29: Band saw or hardwood band saw for winter wood cutting;

13/29: Band saw or softwood band saw for summer wood cutting;

4/32: used to cut band saws for very hardwood;  
7/34: For hardwood, cutting band saw

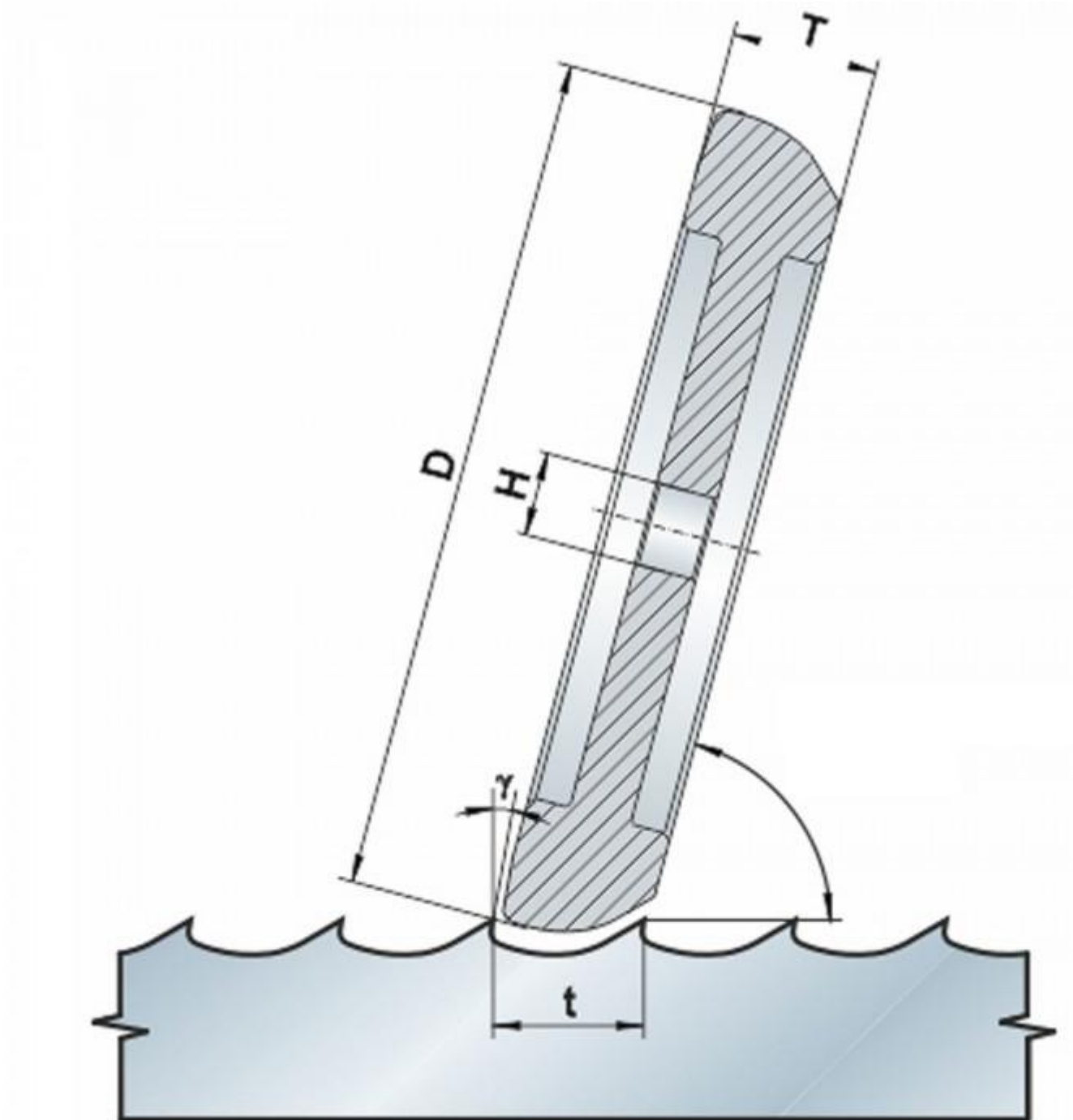

Main Features of CBN grinding wheel for band saw blade sharpening

1. Sharp: Fast sharpening the band saw blades with exact profile and excellent finishing
2. Long Life: Super long life than traditional abrasive wheels
3. Cost-effective: Unit costs is much lower.
4. 10/30, 9/29, 13/29, 4/32, 7/34 degrees and non-standard degrees are available

5. Oil cooling is recommended
6. Exact balancing each wheel
- 7.No loss of profile during grinding, no dressing required
8. Wheel cores can be recycled and replated, thus reducing waste
9. Suitable for Vollmer, Wood-Mizer, Westron, Lorocho, Timber Wolf, Timbery, Norwood

Item	Machine Type	D	T	H	
CBN wheel	Fenes, Ro-Ma	127	22.2	12.7	
		150	22.2	20	
		203	22.2	32	
	Sword	127	9	12.7	
		Wood-Mizer 10/30	127	22.2	12.7
			150	22.2	20
	Wood-Mizer 9/29	203	22.2	25.4	
		203	22.2	32	
		127	22.2	12.7	
		203	22.2	25.4	
		203	22.2	32	
	Other Machine	WM 10/30, WM 13/29, WM 12/28, WM 9/29,			
WM 6/30, WM 7 / 39.5, Lenox 10/30					