



SERVICE MANUAL

HOT WATER CIRCULATION PUMP

Model:CPHB



- Warning
- Ground motor before connecting to power supply.
 - Do not touch the pump while it is running.
 - Do not run the pump without water.

SHIMGE PUMP INDUSTRY GROUP CO., LTD.

Contents

I. Product Overview	1
II. Product Specification	1
1. Model Description	1
2. Configuration	2
3. Performance Curve	3
III. Installation and Use and Notes	4
1. Pumping Medium	5
2. Medium and Ambient Temperature.....	6
3. Pump Installation	7
4. Junction Box Location	8
5. Power Line Installation	9
6. Method for Eliminating Air in the Pipeline.....	10
7. Way to Eliminate Air in the Pump	11
IV. Troubleshooting	12

IV. Troubleshooting

Failure Phenomenon	Main Cause	Exclusion Method
Failed running	The power connection is loose	Connect the power line reliably
	The fuse is burned out	Replace the fuse
	The capacitor is damaged	Replace the capacitor
	The impeller and motor are wound by fiber or blocked by impurities	Remove the fiber and impurities
pump running with noise	There is impurity in the pump	Dismantle the pump and clean the impurities
	Pump flow is set to be too large	Switch to low rotating speed
	There is air in the system or pump	Eliminate air
pump running without pressure	The inlet valve is closed	Open inlet valve
	There is air in the pipe or the pump	Open the valve to run the pump while tightening the connector at the pump outlet to eliminate the air
pump running with small flow	Small pump flow	Add another set or replace a larger pump with large flow

I. Product Overview

- The CPHB series hot water circulating pump adopts canned motor structure. The motor stator is completely shielded and the rotating parts are submerged in the delivery liquid, which cools the motor and lubricates the bearings. The product is low in noise and free of leakage; if it operates with total head without overloading, usually it needs no repair.
- There are three levels on switch knobs of the junction box and they are used to adjust power and change the flow and head of the pump. level 1 is low speed with minimum flow and head; level 2 is medium speed; level 3 is the rated rotating speed, namely high speed level with maximum flow and head;
- Targeting at the hot water circulating system design, the product is applicable to HVAC, air conditioning, industrial circulating system, circulating system of the heat pump hot water, solar energy and boiler hot water, pressurization for domestic water and other fields.

II. Product Specification

1. Model Description

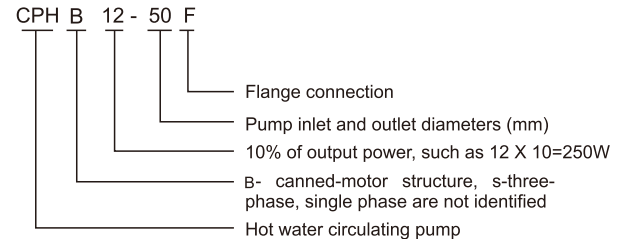

1. Configuration

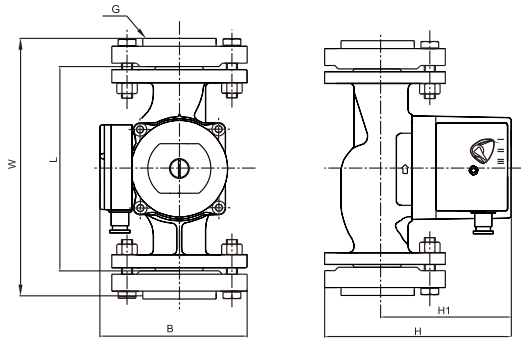

Model No	H	h1	L	B	W	G
CPHB04-25F	135	105	150	130	194	1"
CPHB04-32F	135	105	150	130	194	1 1/4"
CPHB10-40F	185	130	210	150	264	1 1/2"
CPHB10-50F	185	130	210	150	264	2"
CPHB12-40F	185	130	210	150	264	1 1/2"
CPHB12-50F	185	130	210	150	264	2"

7. Way to Eliminate Air in the Pump

After eliminating air in the system, it is necessary to eliminate air in the pump in order to ensure the optimal running state.

Note: Do not make water column or drops enter the junction box in order to avoid electrical failure.

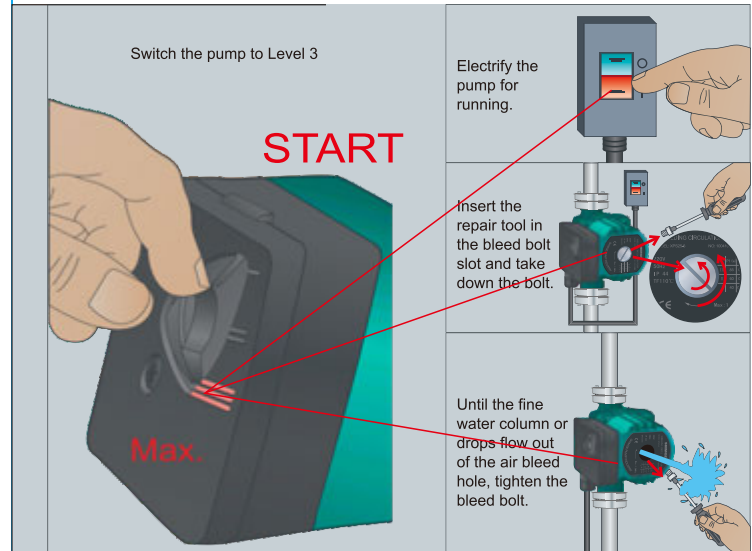

6. Method for Eliminating Air in the Pipeline

To make it easy for eliminating air in the system, it is suggested to install automatic vent valve in the pipeline. If the pump is applied in the domestic hot water system, then open the tap after switching on the water source to eliminate the air in the system.

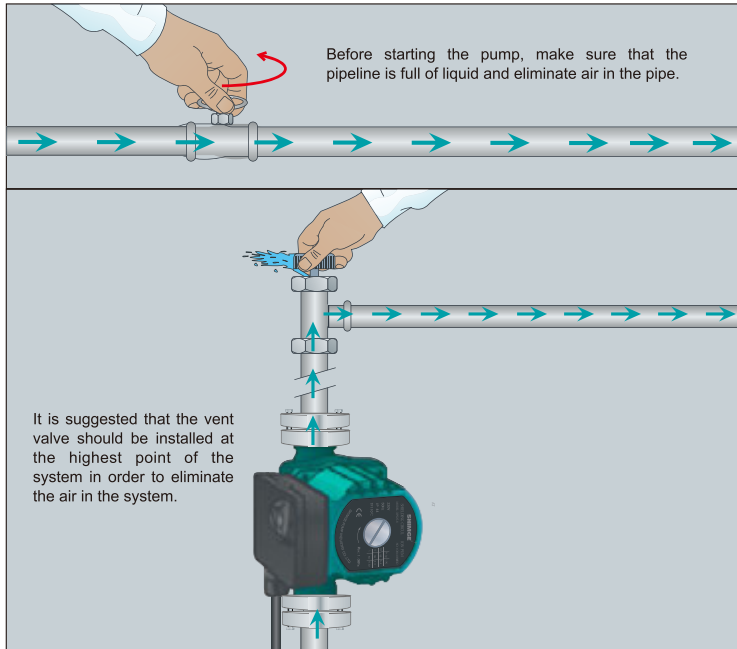

3. Performance Curve and Performance Parameters (Level 3)

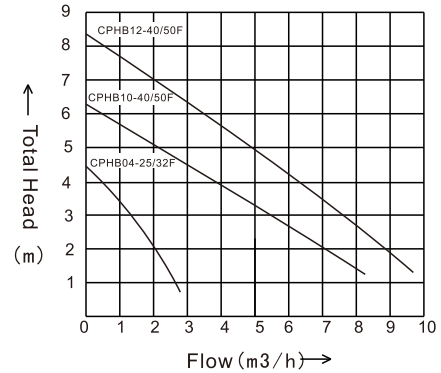

S.N.	Model No	Power	RPM r/min	Rated Power (W)	Input Power (W)	Pipe Diameter	Rated Flow (m ³ /h)	Rated Head (m)	Max. Flow (m ³ /h)	Max. Head (m)
1	CPHB04-25F	220W/50Hz	2650	30	60	25mm (1")	1.5	2.5	3	4
2	CPHB04-32F			30	60	32mm (1 1/8")	1.5	2.5	3	4
3	CPHB10-40F			80	160	40mm (1 1/2")	3.2	3.5	6	5
4	CPHB10-50F			80	160	50mm (2")	4	3.5	8	5
5	CPHB12-40F			120	260	40mm (1 1/2")	4	4.5	8	8
6	CPHB12-50F			120	260	50mm (2")	5	4.5	10	8

III. Installation and Use and Notes

- Before installing the pump, it is necessary to check whether the pipeline system is reliably connected and ensure that the impurities, welding slag, dirt and so on in the pipeline have been removed; the power frequency is 50Hz, the voltage is 220V and the voltage fluctuation should be $-10\% \sim +6\%$.
- The pump should be installed in a dry and well-ventilated area in case of short circuit due to dampness or water splashing and should be easy for maintenance and replacement in the future;
- When the pump is installed in an open air, it needs protective cover, While for indoor installation, it should prevent water splashing in order to avoid electric shock. Never install it in the bathroom, where the water vapor or water might enter the junction box and cause electric leakage.
- After installation, try to run the pump after powering on and set the speed regulating switch to the rated high speed level, check whether startup is normal but the idling duration should not exceed 5 seconds in case of dry running affecting service life of the bearings;
- To facilitate pump repair in the future, it is suggested to install a separate shutoff valve at the inlet and outlet of the pump respectively.
- When the pump supplies water for the supporting heating system, never touch the pump or pipeline in case of scalding;
- The power outlet should be strictly grounded and the plug grounding pin and the power outlet grounding hole should be reliably connected. Never change the grounding plug without authorization;
- When the pump operates, set up noticeable safety warning signs at the site in case of accidents;
- 9. When the pump operates, if you want to adjust the pump location or touch the pump, power must be cut off firstly to avoid the accidents.
- Regularly check, if damage occurs, it needs to replace immediately;
- Regularly check the pump insulation resistance and the cold insulation resistance should not be lower than $50M\Omega$. When approaching the working temperature, the insulation resistance should not be lower than $5M\Omega$;
- If the cables are damaged, it is required to use special cable or purchase special components to replace the cables.
- In winter, when the ambient temperature is lower than 0°C , if the pump stops running, it needs to drain the water in the piping system in case of frost cracking of the pump;

5. Power Line Installation

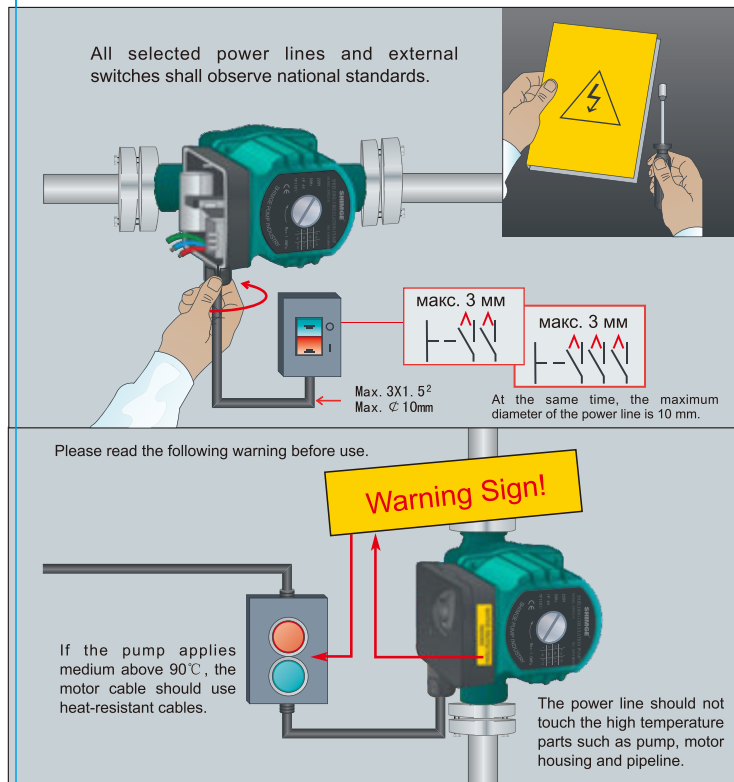

4. Pump Repair and Method for Adjusting the Junction Box Location

Operations in this page should be done by professionals.

Be sure to close the water source valve before pump repair.

Repair after the pump cools down in case of personal injury due to hot liquid.

1 The junction box can be adjusted due to different installation locations. Before installation, please confirm that the power switch and the water source switch are closed. After the pump cools down, loosen the four bolts that connect the motor and the pump at a time.

2 Separate the motor and pump

3 Rotate the motor until the junction box is in place, then tighten the four bolts in sequence until the motor and the pump are completely sealed and connected.

220V	50Hz
IP: 44	TFF110 C

Junction box should not be at the location of "X" in the figure.

- Do not frequently replenish non-softened water in the heating pipe in case of increase of calcium in the pipeline, which might block the impeller.

1. Pumping Medium

The pumping medium is water and thin, clean, non-corrosive, non-explosive, solid particle, fiber and mineral oil –free liquid.

Maximum pressure for pump 1.0Mpa (10bar)

To avoid cavitation noise and damage to the pump bearings, the following minimum pressure should be maintained at the pump inlet.

Liquid temperature	85°C	90°C	100°C
Inlet pressure	0.5mhead 0.05bar	2.8mhead 0.28bar	11.0mhead 1.1bar

2. Medium and Ambient Temperature

It is suggested that the system temperature (t_1) should be higher than the ambient temperature (t_2) in case of moisture condensation in the pump, which might cause short circuit in the junction box.

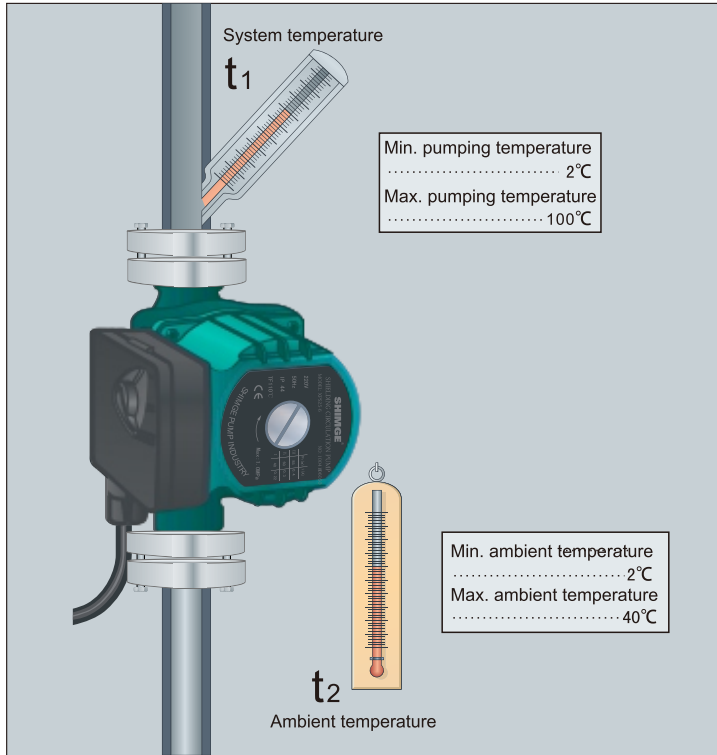

3. Pump Installation

During installation, it needs to maintain the motor shaft level and the make the direction of flow in the pipe consistent with the arrow direction identified in the pump;

