

**SHIMGE**<sup>®</sup>  
.....———*for better life*

**SERVICE MANUAL**  
**SUBMERSIBLE SEWAGE PUMP**

Models:Q(D)X、Q(D)、Q(D)Y-K2、QY

**SHIMGE PUMP INDUSTRY GROUP CO., LTD.**

# Contents

I. Product Introduction

II. Operating Conditions

III. Structural Diagrams

IV. Installation & Use and Matters Needing Attention

V. Maintenance

VI. Troubleshooting

Thank you very much for choosing our products, and please read over the operating manual and keep it properly prior to installation and use.



- **The Electric Pump must be grounded reliably before use, and shall be equipped with an electrical leakage protection device;**
- **It's strictly prohibited to touch the Electric Pump during operation;**
- **It's strictly prohibited to run the Electric Pump without water;**
- **For three phase-motors with integrated thermal protector shut down due to overload or overheating, it is NOT allowed to re-connect the power until motor cooling for more than 10 minutes.**

## I. Product Introduction

Submersible electric pumps (hereinafter referred to as the “electric pumps”) include Q(D)X, Q(D), Q(D)Y-K2, and QY electric pumps. The electric pump is composed of water pump, sealing and motor. For Q(D)X electric pumps, the motor is single-phase or three-phase asynchronous motor, located in the upper part of electric pump, and the water pump is of centrifugal type impeller-volute structure, located in the lower part of electric pump; for Q(D) and Q(D)Y-K2 electric pumps, the water pump is of multi-stage centrifugal type impeller & radial guide vane structure, located in the upper part of electric pump, and the motor is single-phase or three-phase asynchronous motor, located in the lower part of electric pump; for QY electric pumps, the water pump is of centrifugal, axial-flow type or mixed-flow type, located in the upper part of electric pump, and the motor is oil-filled three-phase asynchronous motor, located in the lower part of electric pump. Mechanical seal is adopted between water pump and motor, and “O”-shaped oil resistant rubber seal rings are adopted at fixed rabbet seals as static seal to ensure the reliability of electric pump.

With high lift and widespread applicability owing to the adoption of multi-stage impeller structure, this series of electric pumps are essential water delivery equipment in such applications as farmland irrigation and drainage, spray irrigation, landscape spray irrigation, well water lifting, water supply for tower, and water supply & drainage in breeding industry. Due to the adoption of corrosion-resistant materials for flow passage components, QD-P series of electric pumps are particularly suitable for water supply & drainage in sea farming.

## II. Operating Conditions

Electric pump shall be able to operate continuously and normally in the following operating conditions:

1. The temperature of medium is no higher than +40°C;
2. The pH value of medium is 6.5~8.5;
3. The volume ratio of solid impurities is no more than 0.1%, and the particle size is no more than 0.2mm;
4. The supply frequency is 50Hz, the voltage is single-phase AC 220V or three-phase AC 380V, and the fluctuation range of voltage is  $\pm 10\%$  of the rated value;
5. The immersion depth is no more than 5m. The immersion depth of Q(D)Y-K2 is no more than 30m.

### III. Structural Diagrams

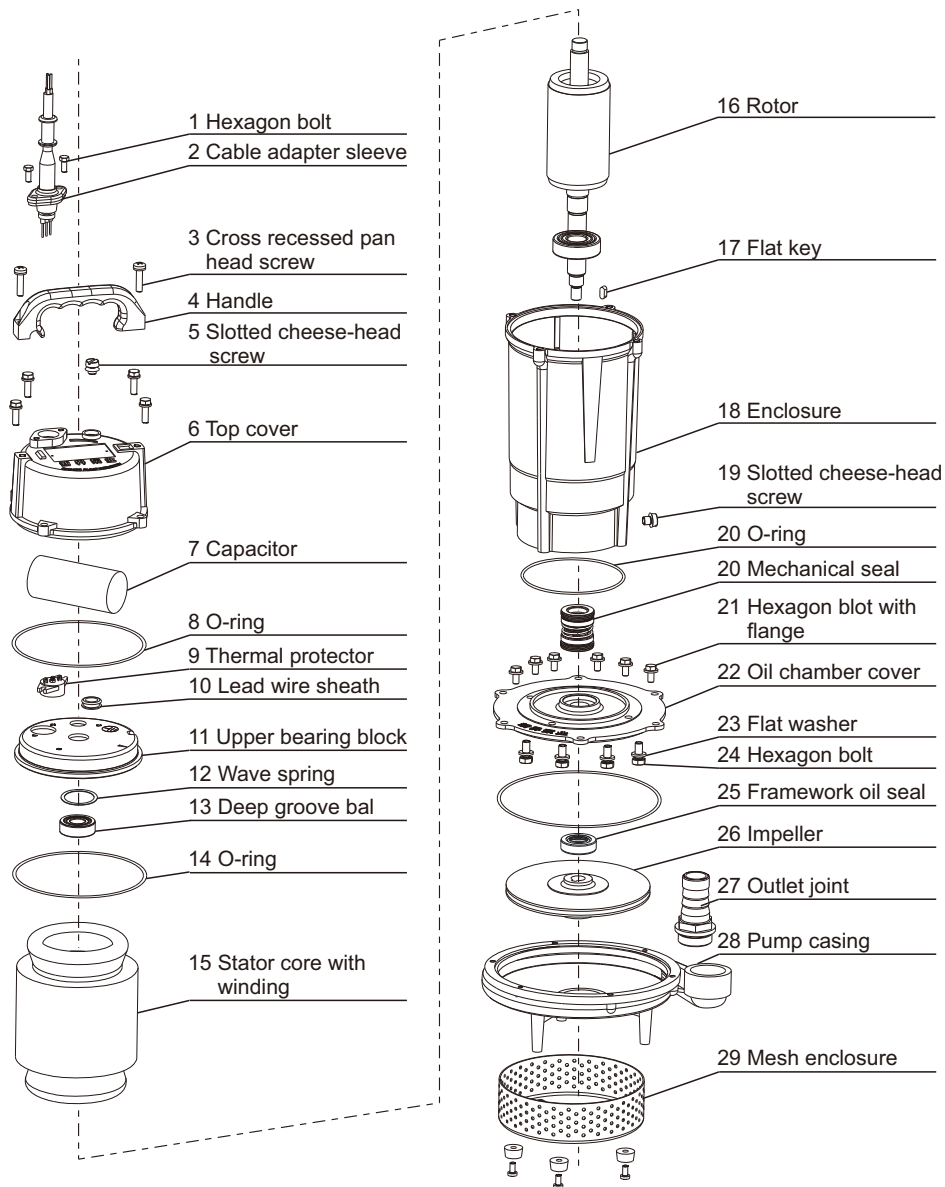

**Q(D)X Series**

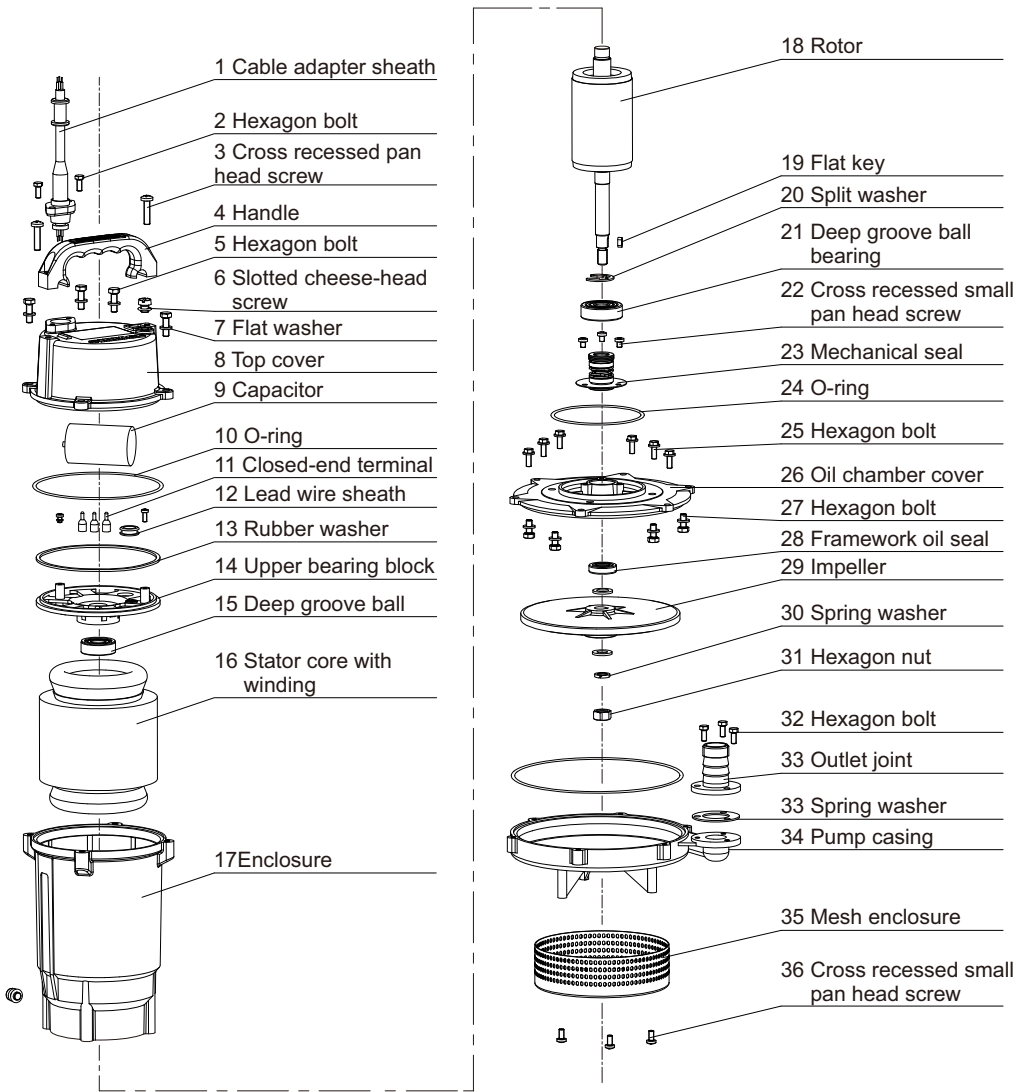

**Q(D)X-L2 Series**

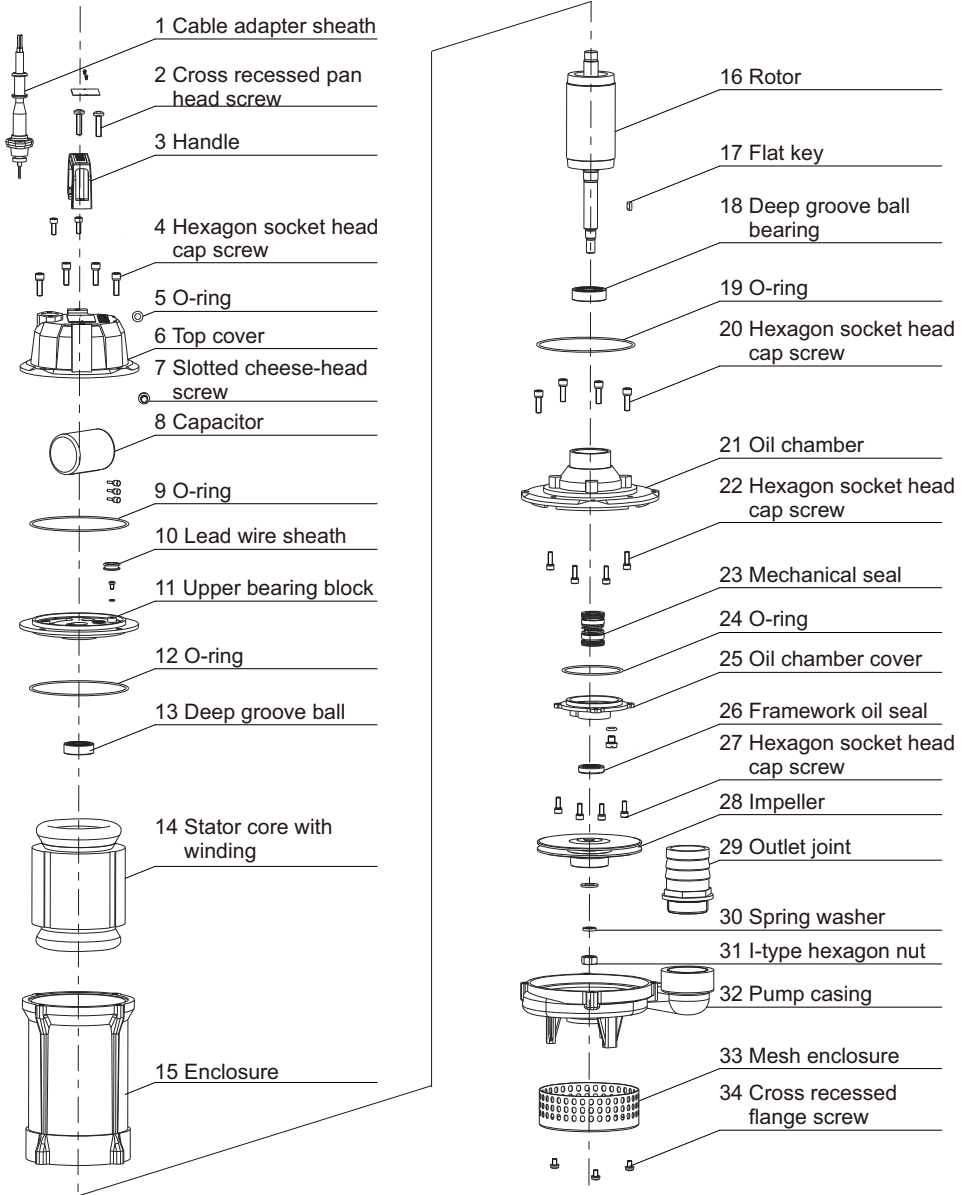

**Q(D)X-T2 Series**

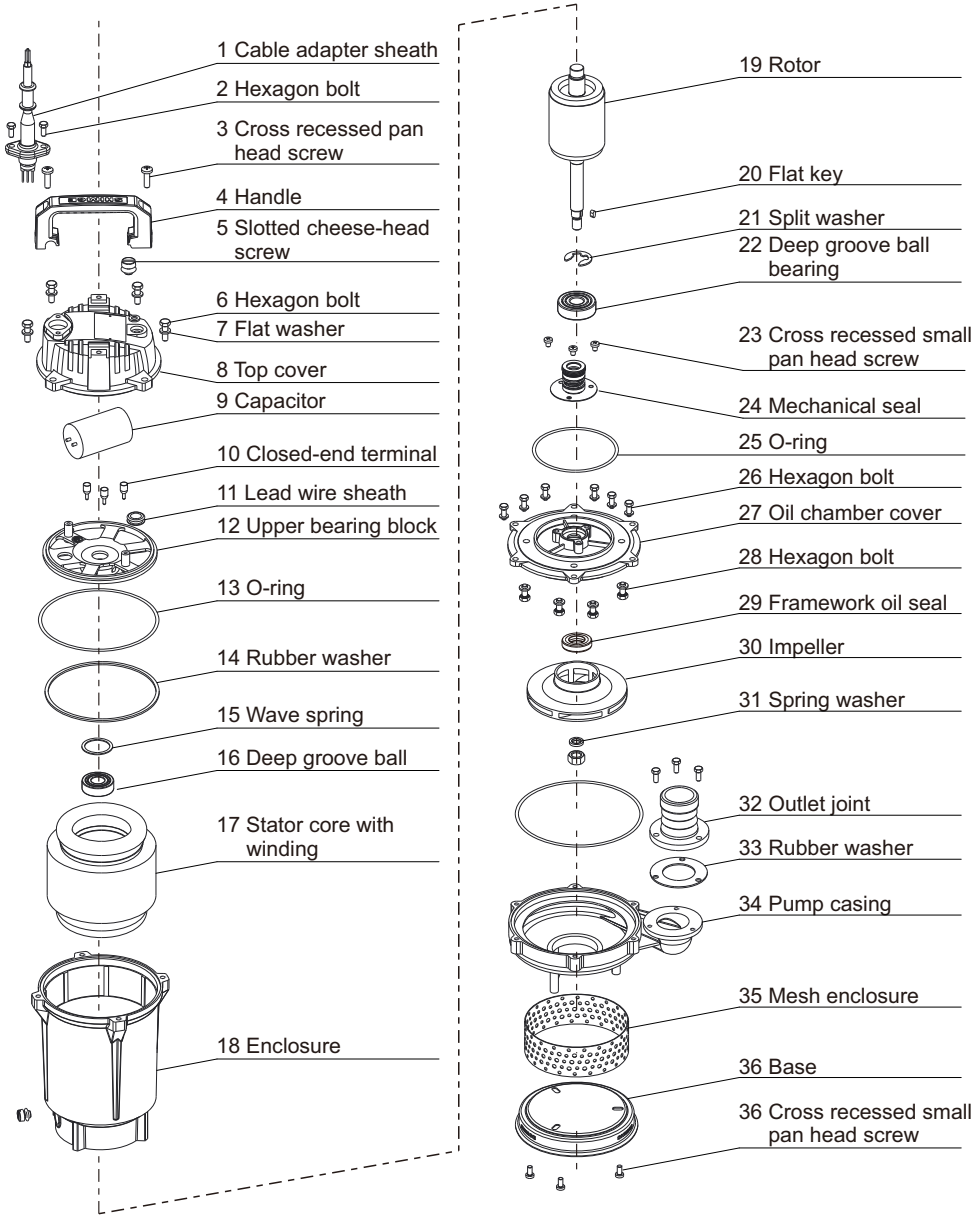

**Q(D)X-K1 Series**

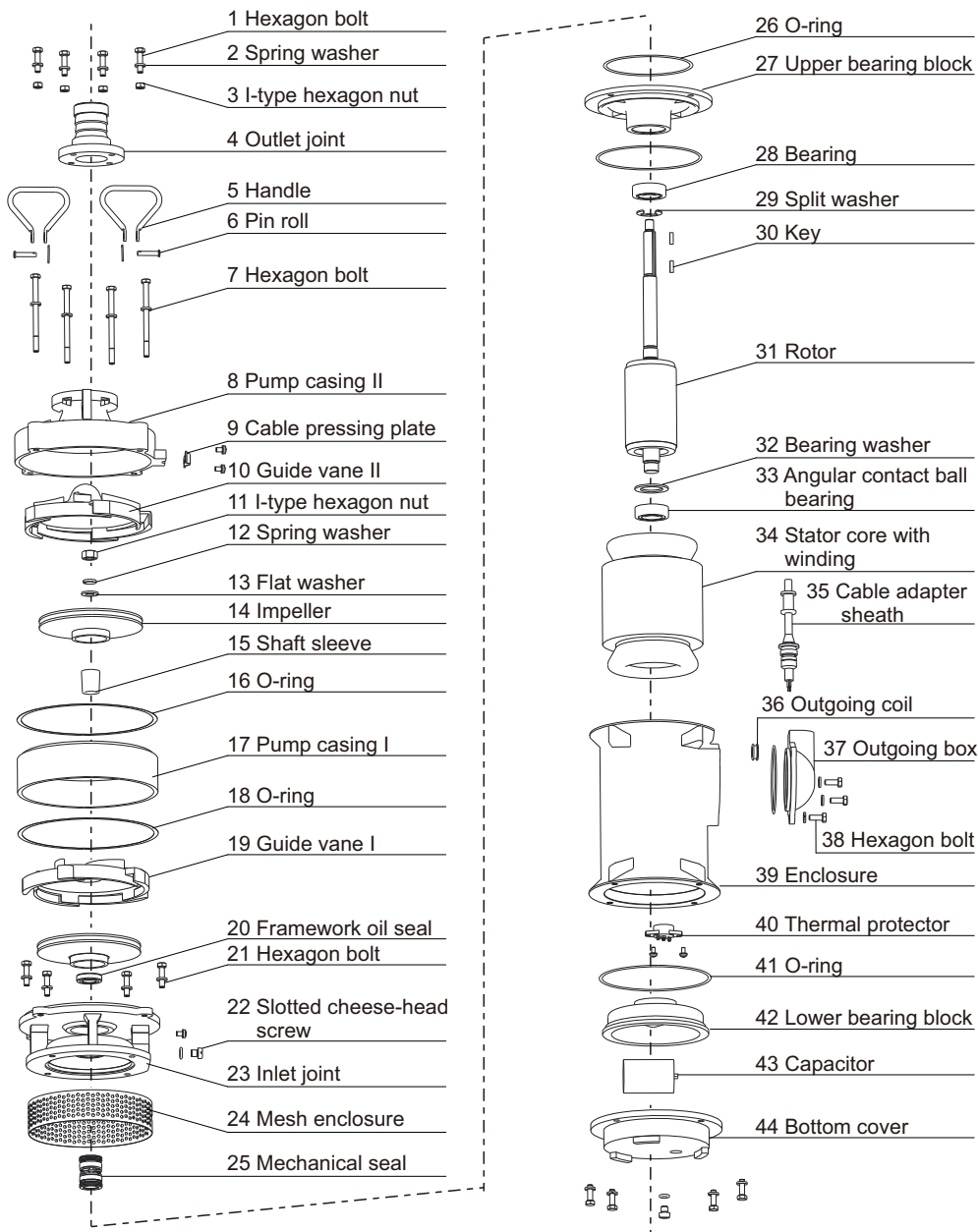

**Q(D)-J Series**



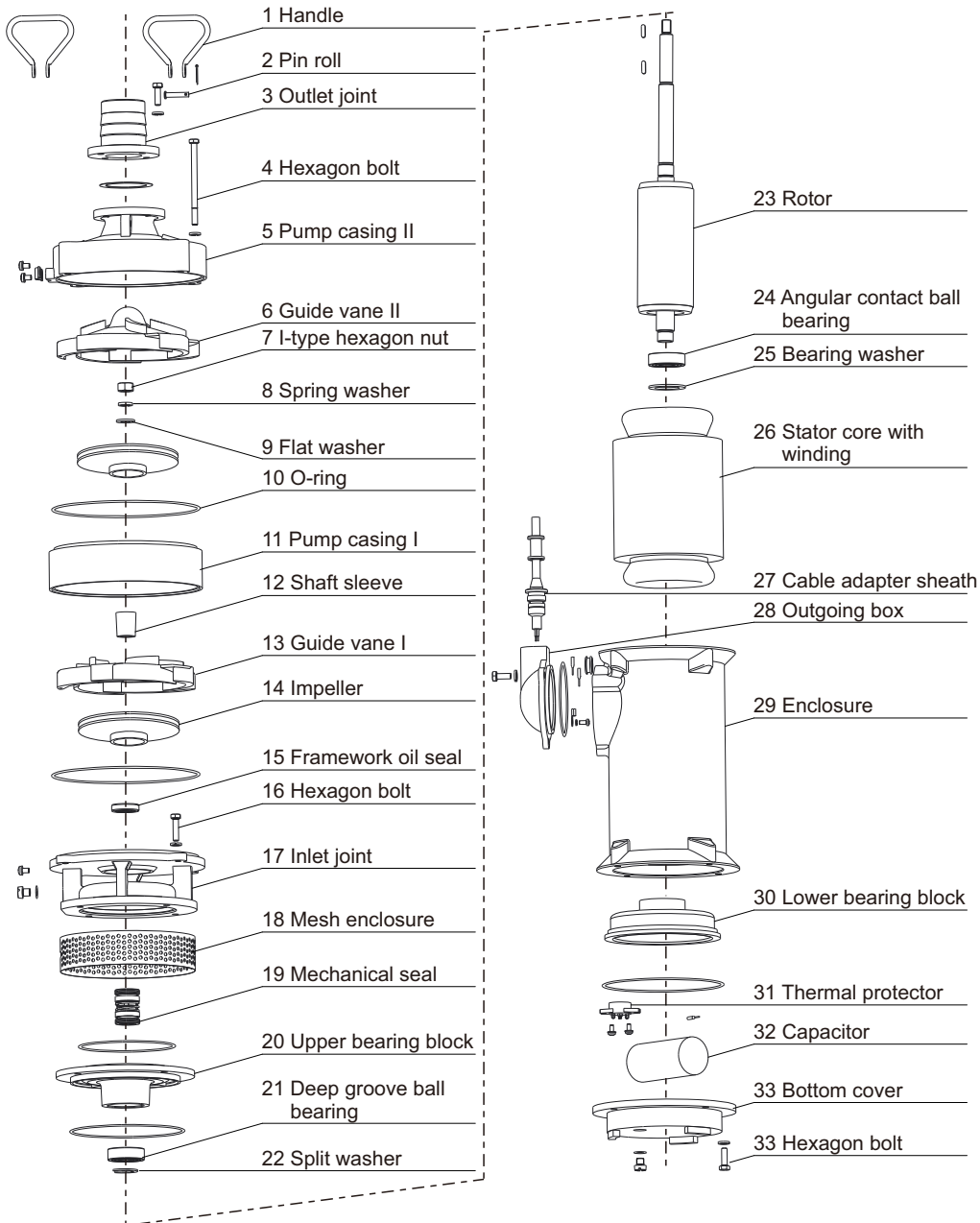

**Q(D)-P Series**

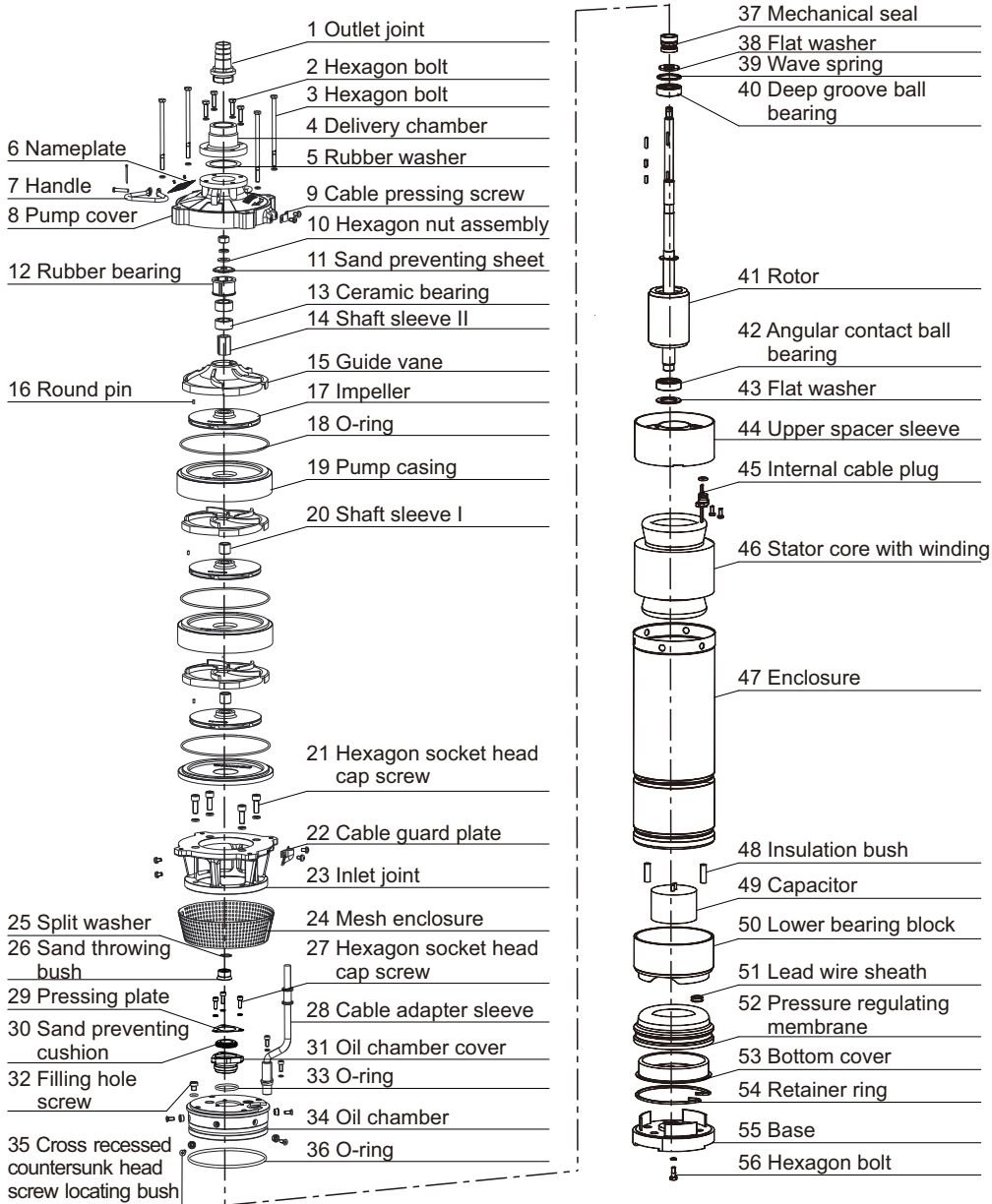

**Q(D)Y-K2 Series**

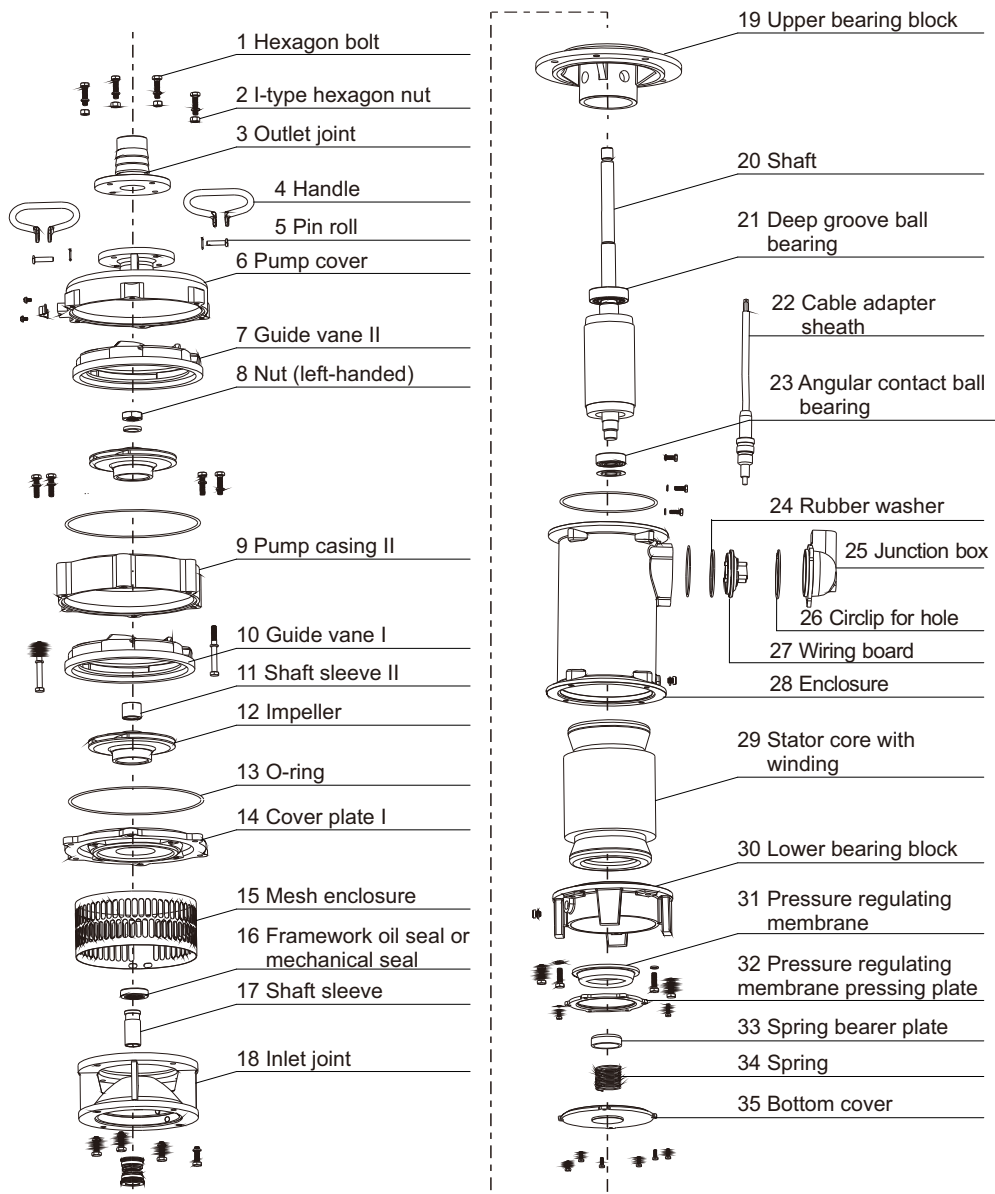

**QY Series**

## IV. Installation & Use and Matters Needing Attention

1. Electric pumps shall be comprehensively checked for damages affecting safety or product performance during transportation and storage prior to installation and use, e.g. whether cable and plug are in good condition, and in case of any damage, replacement or repair shall be made by professionals prior to use.

2. Before operation, electric pumps shall be checked for insulation resistance, and the cold insulation resistance of electric pumps must be greater than 50M $\Omega$  (megohm).

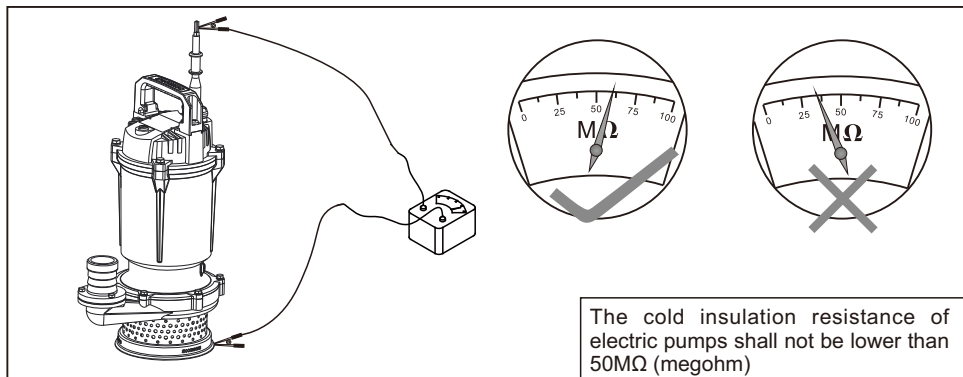

3. At wiring, electric pumps should be correctly installed with electrical leakage protector (if not equipped at delivery, the user should buy it by itself). For three-phase electric pumps, a yellow-green wire attached with earthing mark in the outgoing cable shall be earthed reliably. Matched overload protection devices shall be selected by current or power given in the table of technical parameters for all electric pumps. The wiring of electric pumps can be carried out according to the figures below. For electric pumps provided with plug at delivery, the matched patch board must be reliably earthed.

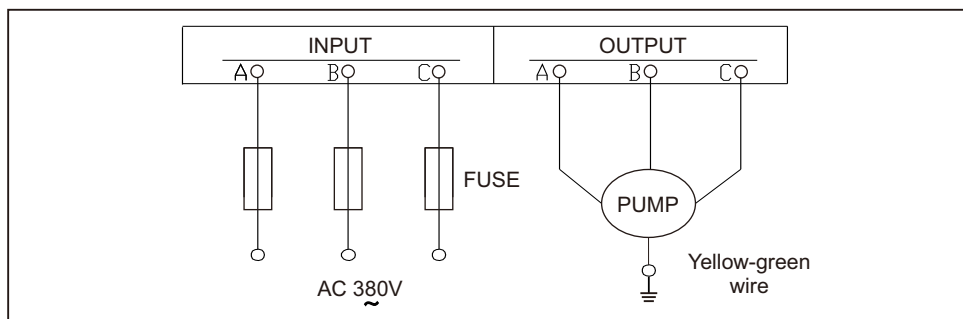

**Wiring diagram of protection devices for Q(D)X, Q(D) and Q(D)Y-K2**

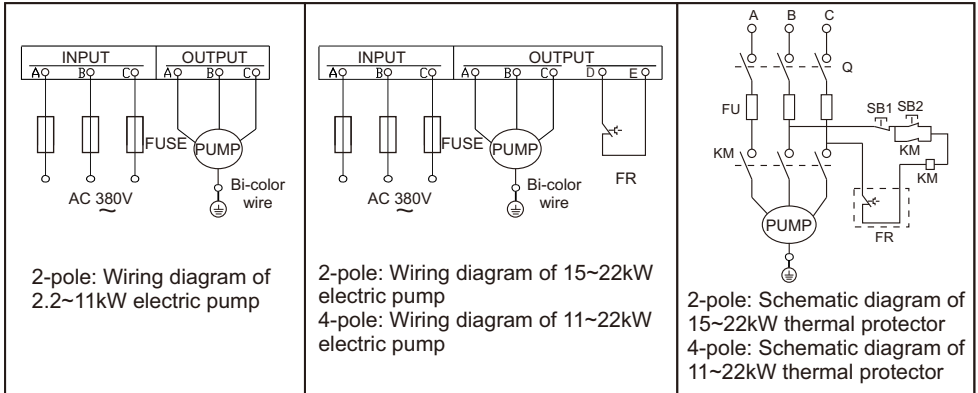

### Wiring diagram of protection devices for QY

4. The two thinner wires in the outgoing cable of 15~22kW (two-pole) electric pumps and 11~22kW (four-pole) electric pumps are thermal protector signal wires (FR); when electric pump runs normally, the thermal protector is in close state, and the signal wire is connected; when electric pump runs abnormally (overload, phase loss or locked rotor), the winding temperature rises to make the thermal protector of any phase act, the signal wire becomes open, and the signal wire (FR) is adopted as the control switch of thermal protector of control circuit (see also the schematic diagram of thermal protector). After the action of thermal protection, the signal wire can be connected only after the electric pump is cooled and the temperature lowers to the reset temperature of thermal protector. (Note: When the thermal protector acts and the signal wire becomes open, the electric pump shall be troubleshooted prior to further operation.)

5. Electric pumps shall be subjected to test run for no more than 10s before immersion into water, and it shall be checked whether the direction of rotation of electric pump is consistent with the indication arrow; if it's found a three-phase electric pump reverses (no reverse for single-phase electric pumps), the power shall be cut off at once, and any two of the three phases (except earth wire) should be exchanged with each other. ps provided with plug at delivery, the matched patch board must be reliably earthed.

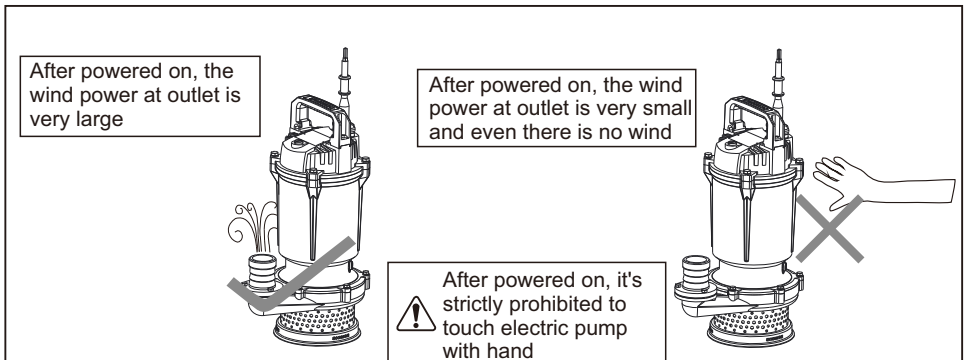

6. At the connection of deliver pipe matching with outlet joint, flexible delivery pipe can be tightened with iron wire or clamp, steel delivery pipe can be reliably connected with screwed joint, and a rope should be reeved through the handle or lift ring for lifting of electric pump in the water.

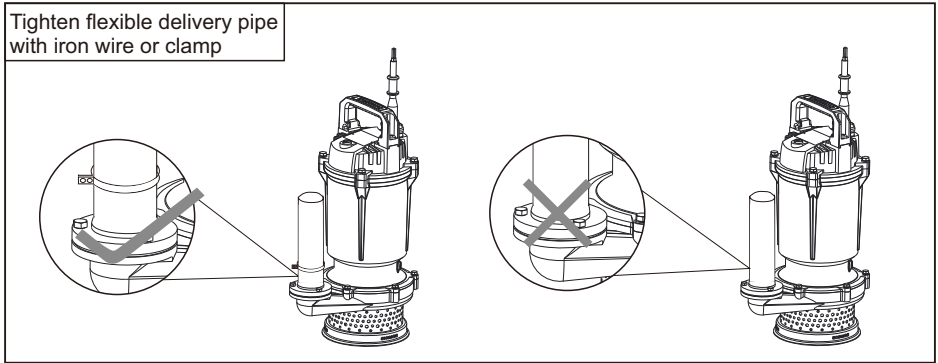

7. It's strictly prohibited to strike or roll over cable, nor shall it be used as lifting rope; during the operation of electric pump, cable shall not be pulled at will to avoid electric shock accidents due to damage of cable.

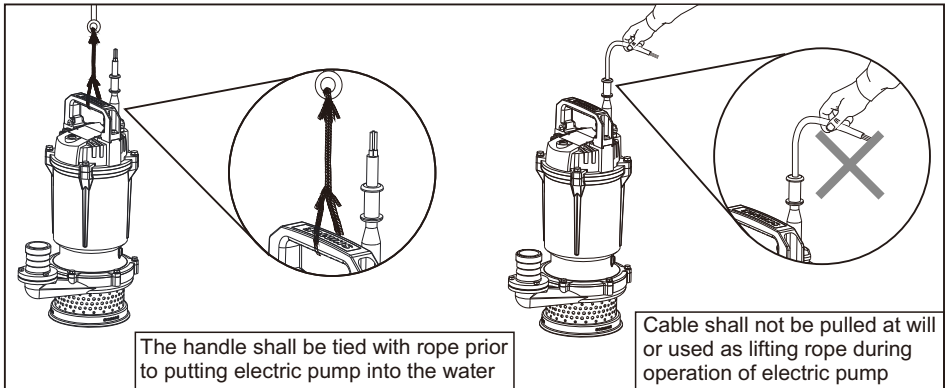

8. When electric pump is immersed in the water, the depth shall not exceed 5m, and it shall be more than 0.5m from the water bottom. Electric pump shall not immerse into mud, and the impeller shall be prevented from being blocked or jammed by water plants or debris, resulting in that electric pump cannot work normally; the fall of water level should be checked frequently during operation so as not to let electric pump work out of water surface.

**The depth of immersion of Q(D)Y-K2 is no more than 30m.**

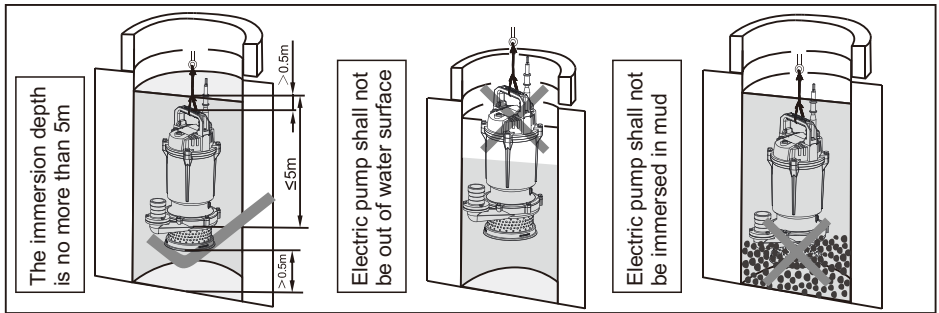

9. When electric pump is running, the safety warning sign of “Shock hazard, no man or animal shall enter” shall be arranged at the work site to avoid accidents.

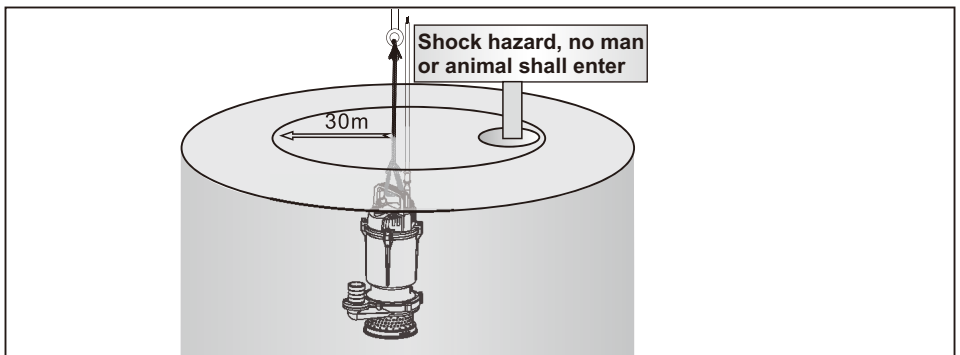

10. For single-phase electric pumps with built-in automatic reset type thermal protector, after the protector acts, it can reset automatically when the temperature rise of motor lowers to a certain value, and in case of frequent action of protection, the power shall be cut off for troubleshooting prior to further use. For three-phase electric pumps with power-off reset type thermal protector, after the protector acts, the power must be cut off for 10min, and then the electric pump can run normally; in case of frequent action of protection, the power shall be cut off for troubleshooting prior to further use.

11. For electric pumps not used with total lift (the upper and lower limits of lift are specified), they must be used within the usable range of lift to avoid damage of electric pumps due to overload. For electric pumps used with total lift, the pipe diameter adopted shall be consistent with but not greater than the specified pipe diameter to avoid overload.

12. When electric pump is running, if it is needed to adjust the position of electric pump or touch the electric pump, the power must be disconnected first to avoid accidents.

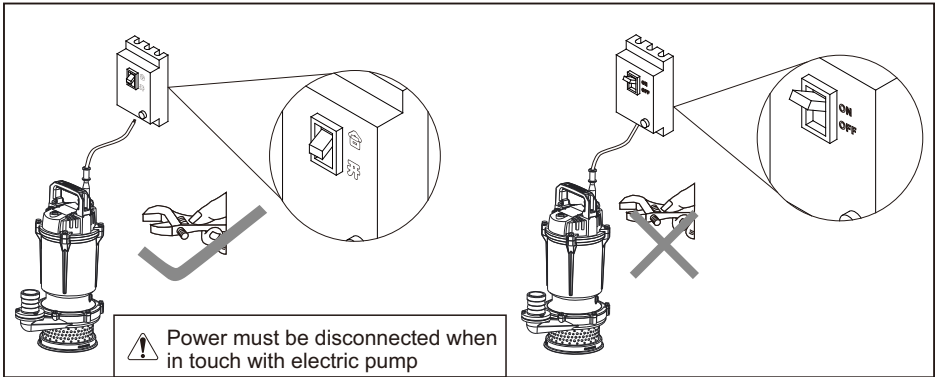

13. When electric pump is running, it's strictly prohibited to immerse cable joints or plug boards into the water; if this is needed for extension of cable, the joints shall be sealed and covered strictly to avoid electric leakage due to water seepage. (Refer to the figure below)

<p>①</p>	<p>②</p>	<p>③</p> <p>No less than 10 times of conductor diameter</p>
<ol style="list-style-type: none"> <li>1. Remove the insulating layer without damaging conductor</li> <li>2. Stagger several conductors in length</li> <li>3. Ensure no oil, water or other dirt at the joint</li> </ol>	<ol style="list-style-type: none"> <li>1. Tighten up the joint by dividing it into several strands evenly (at least 6 strands).</li> <li>2. Cross two joints by such a length that the wire ends reach the insulating layer at both ends.</li> </ol>	<ol style="list-style-type: none"> <li>1. Tighten up the strands together, take out one strand from the middle and twine it to one end (the twined core wire contains the other strands), and then twine other strands one by one.</li> <li>2. Repeat the step above at the other end.</li> <li>3. Tighten the joint with pliers, and coat the joint with tin to achieve the best effect.</li> </ol> <p>Note: See the attached figure 1 and attached figure 2 for other methods</p>



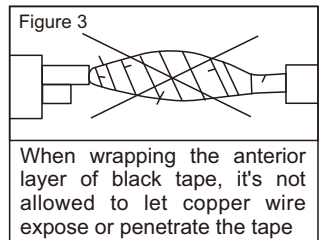
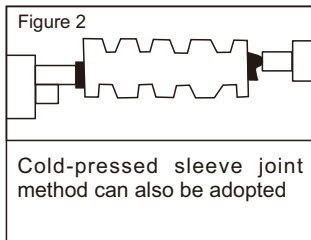
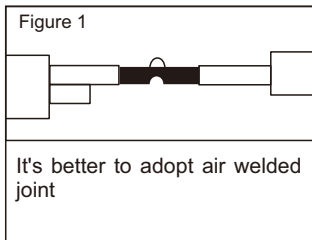
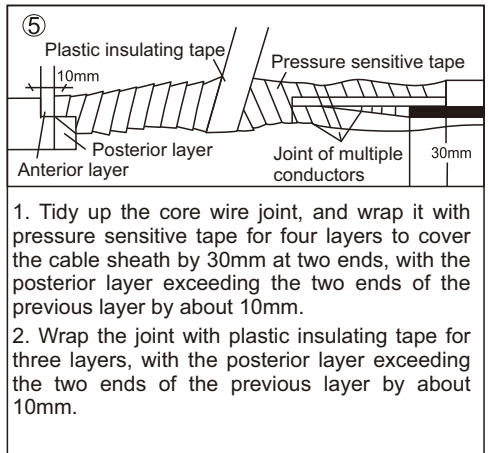
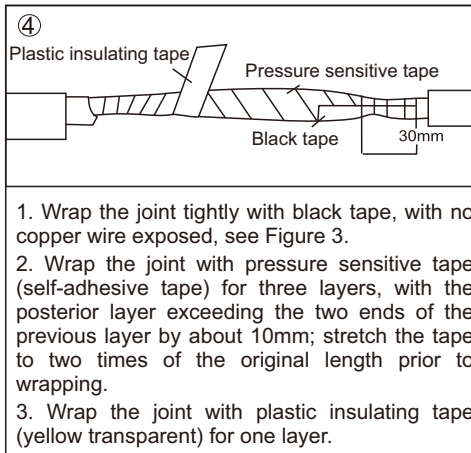

### Cable Wiring Diagram

14. After electric pump is powered off, it can be lifted out of water surface only after electric motor is cooled to room temperature to ensure safety.

## V. Maintenance

The insulation resistance between pump winding and enclosure shall be checked regularly, and the insulation resistance must be greater than  $1M\Omega$  (megohm) when approaching the working temperature; otherwise, corresponding measures must be taken to reach the requirements prior to use.

2. After electric pump is normally used for 2500 hours, it shall be sent to qualified maintenance stations for maintenance by the following steps:

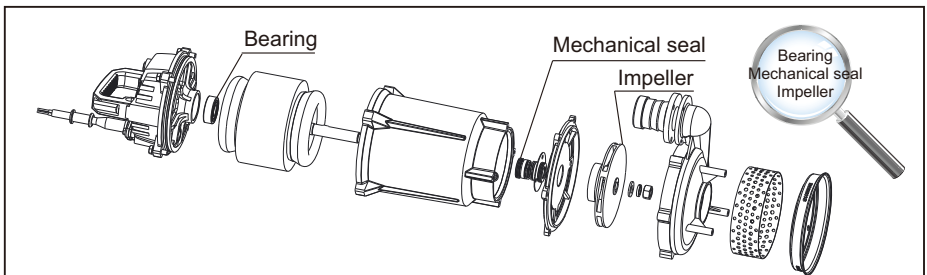

Air pressure test: After electric pump is disassembled for repair or a seal is replaced, the motor cavity and seal cavity must be subjected to air pressure test, the test pressure is 0.2MPa (megapascal), and no leakage or sweating shall occur in a duration of 3min.

Oil replacement: Unscrew the oiling screw at oil chamber, and replace used oil with clean No.10 white oil for food-level machinery (to reach 95% volume of chamber).

3. If electric pump is not used for a long time, it should not be immersed in the water; electric pump shall be placed in clean water to run several minutes, cleaned to remove coagulations inside and outside the pump, dried, subjected to anti-rust treatment, and placed at dry and ventilated place. Electric pump which has been used for a long time shall be repainted and subjected to anti-rust treatment depending on its surface corrosion situation.

## VI. Troubleshooting

Fault	Causes	Remedy
Difficulty in starting	<ol style="list-style-type: none"> <li>1. The supply voltage is too low</li> <li>2. Phase loss</li> <li>3. The impeller is jammed</li> <li>4. The voltage drop of cable is too large</li> </ol>	<ol style="list-style-type: none"> <li>1. Adjust the voltage to <math>\pm 10\%</math> of the rated value</li> <li>2. Check switch outlet and cable and plug</li> <li>3. Fix the jammed part</li> <li>4. Select and use reasonable cable</li> </ol>
Low water output	<ol style="list-style-type: none"> <li>1. The lift is too large</li> <li>2. The mesh enclosure is blocked</li> <li>3. The impeller is worn seriously</li> <li>4. The immersion depth of electric pump is shallow, with air sucked</li> <li>5. The impeller reverses</li> </ol>	<ol style="list-style-type: none"> <li>1. Adjust the voltage to <math>\pm 10\%</math> of the rated value</li> <li>2. Check switch outlet and cable and plug</li> <li>3. Fix the jammed part</li> <li>4. Select and use reasonable cable</li> </ol>
Stop running suddenly	<ol style="list-style-type: none"> <li>1. Switch is off, or fuse is burnt out</li> <li>2. The power is disconnected</li> <li>3. The impeller is jammed</li> <li>4. Stator winding is burnt out</li> <li>5. The protector trips off</li> </ol>	<ol style="list-style-type: none"> <li>1. Check whether the lift used or supply voltage meets requirements and adjust it</li> <li>2. Find out the reason of outage and eliminate the faults</li> <li>3. Clear away foreign matters</li> <li>4. Insert winding again for overhaul</li> <li>5. Find causes (the supply voltage is too low, the motor is overloaded, or the impeller is blocked), and eliminate faults</li> </ol>
Stator winding is burnt out	<ol style="list-style-type: none"> <li>1. Phase loss occurs to electric pump or the running time is too long</li> <li>2. Water leaks due to damage of mechanical seal, resulting in turn-to-turn or phase-to-phase short circuit</li> <li>3. The impeller is jammed</li> <li>4. Electric pump starts up frequently or runs out of water too long</li> <li>5. Electric pump is overloaded</li> </ol>	Eliminate the faults, remove the winding and insert the winding again according to the original technical requirements, and apply insulating paint by impregnating and drying, or send it to the maintenance company for repair

### Notes:

1. All the figures in this manual are schematic diagrams, and please understand that the electric pumps and accessories you buy may be different from the diagrams in this manual.
2. The performance of the product is improved constantly, and all products (including appearance and color, etc.) are subject to physical products; no further notice will be given in case of any change.